

## Component Image & Dimension

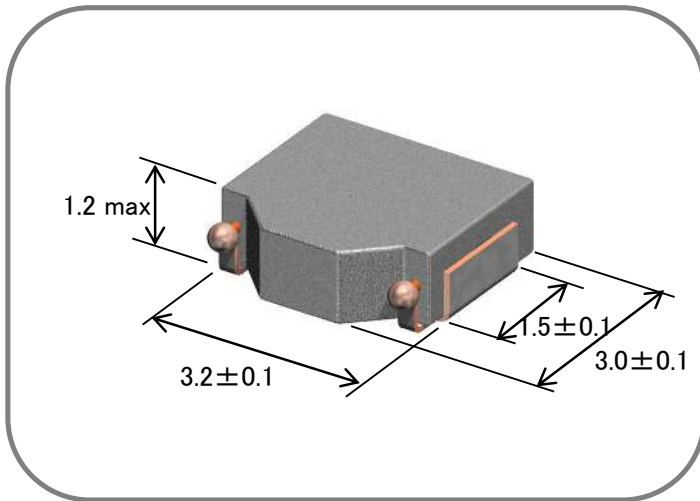

## Features

- a) Small Footprint and Low Profile Design :  
Footprint : 3.2 x 3.0 mm Typ.  
Height : 1.2mm Max.
- b) High Power Handling Capability :  
Small Copper Loss  
Using Large Saturation Induction of Fe- based metals
- c) Wide Range Operating Temperature due to  
High Curie Temperature of metal core
- d) Automatic Mounting in Tape&Reel Package.

## Applications

Note Book & Mobile Computer, VRM,

## Electrical Specification ( Provisional value )

TDK Identification	Inductance		Test Freq. (kHz)	DC Resistance		Rated DC Current		
	at 0A (uH)	Tol. (%)		Spec. (m-Ohm)	Typ. (m-Ohm)	Idc 1 (A) max.	Idc 1 (A) typ.	Idc 2 (A) typ.
SPM3012T- 1R0M-CA	1.0	+/-20%	100	65 max	57	3.4	5.4	2.8
SPM3012T- 1R5M-CA	1.5	+/-20%	100	90 max	77	2.8	4.7	2.5
SPM3012T- 2R2M-CA	2.2	+/-20%	100	115 max	100	2.5	3.4	2.2
SPM3012T- 3R3M-CA	3.3	+/-20%	100	210 max	183	1.8	2.8	1.5
SPM3012T- 4R7M-CA	4.7	+/-20%	100	270 max	232	1.5	2.6	1.3

Note. Idc 1 : Based on the inductance change. (-30% Reduction from Nominal L Value )

Idc 2 : Based on the self temperature rise. (+40 deg typ.)

Operating Temperature Range: -40 °C ~ +125 °C (including self temperature rise)

**Caution: Please contact our sales person when you consider organic solvent or aqueous cleaning.**

## Inductance vs. DC Superposition

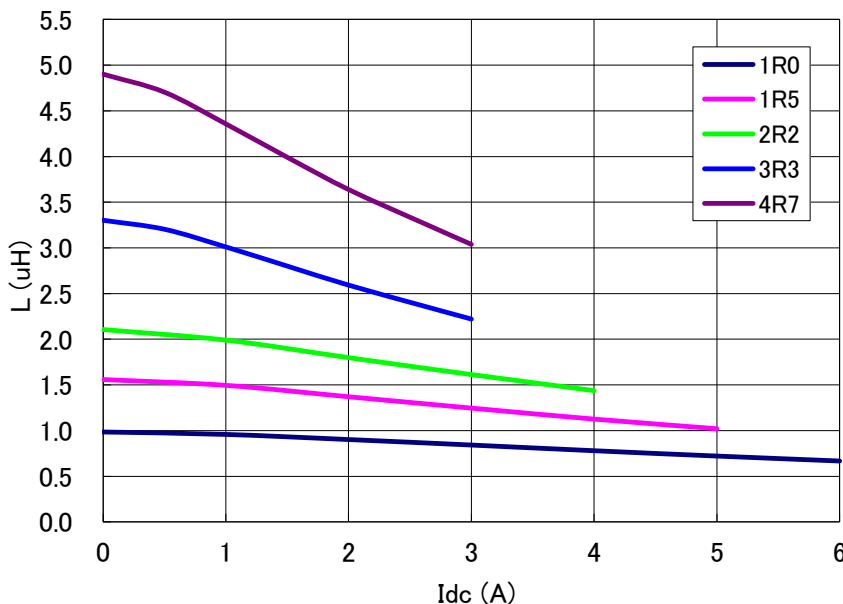

## Recommended pad layout

