



No. EQM08-4KC-D3BX720E

PRELIMINALY

Messrs : _____

APPROVAL SHEET
(KYOCERA CORPORATION PIEZO BUZZER SPECIFICATION)
(RoHS Compliant Product)

APPROVED

(Please signs here and send copy back to us.)

Kindly send us back a copy of this specification sheet with your signature.
The specifications shall be regarded as "APPROVED" unless we received your disagreement or Counterproposal before your placement of initial order for the part number specified.

Part No. KBT-33SB-2T-2

Date Mar. 10. 2008

KYOCERA CORPORATION

Drawn by

Checked by

 Checked by

 Approved by

1.SCOPE

This specification shall cover the characteristics of the Piezoelectric Acoustic Generator for Buzzer, Ringer and etc.

2.KYOCERA PART No. :KBT-33SB-2T-2**3.ELECTRICAL CHARACTERISTICS**

	ITEM	SPEC
3-1.	Sound Pressure Level	70 dB min at 1.0 to 1.5 Hz 20Vp-p S.Q.wave 30 cm
3-2.	Capacitance (Cd)	48,000 pF +/- 30%
3-3.	Input Voltage	30 Vp-p max..
3-4.	Operating Temperature	- 20deg. C to + 70deg.C
3-5.	Storage Temperature	- 30deg. C to + 80deg.C
3-6.	Temperature Dependence	As shown in Table 1 at-20deg.C to +60deg.C

Table 1.

Capacitance	Initial Value +/- 1.5 % / deg.C max.
-------------	--------------------------------------

Initial Value at 20 deg.C

4.MEASUREMENT**4-1.Measurement Condition.**

The reference temperature shall be 25+/-2deg.C . The measurement shall be performed at the temperature range of 5deg.C to 35deg.C unless the result is doubtful.

4-2.Measurement Instrument.**Capacitance.**

LCR Meter (Y.H.P.4261A) at 120 Hz.

4-2-3: Sound Pressure Level (SPL)

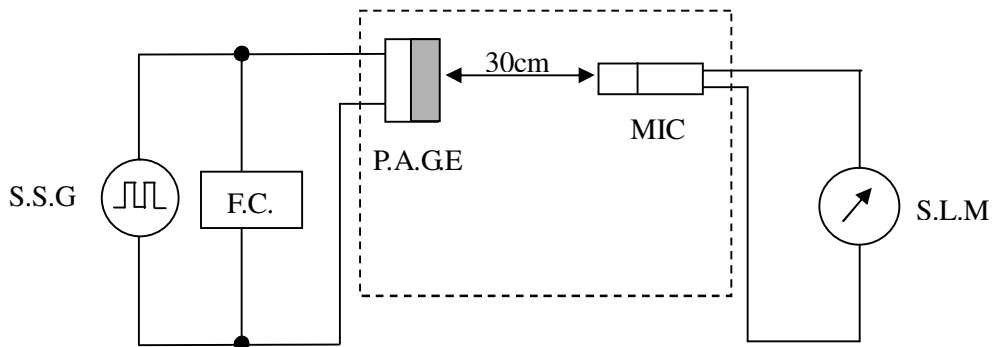

- S.S.G : Oscillator
- F.C. : Frequency Counter
- MIC : Microphone
- SLM : Sound Level Meter
- Input : 20Vp-p S.Q.wave

5. Appearance
5-1. Drawing

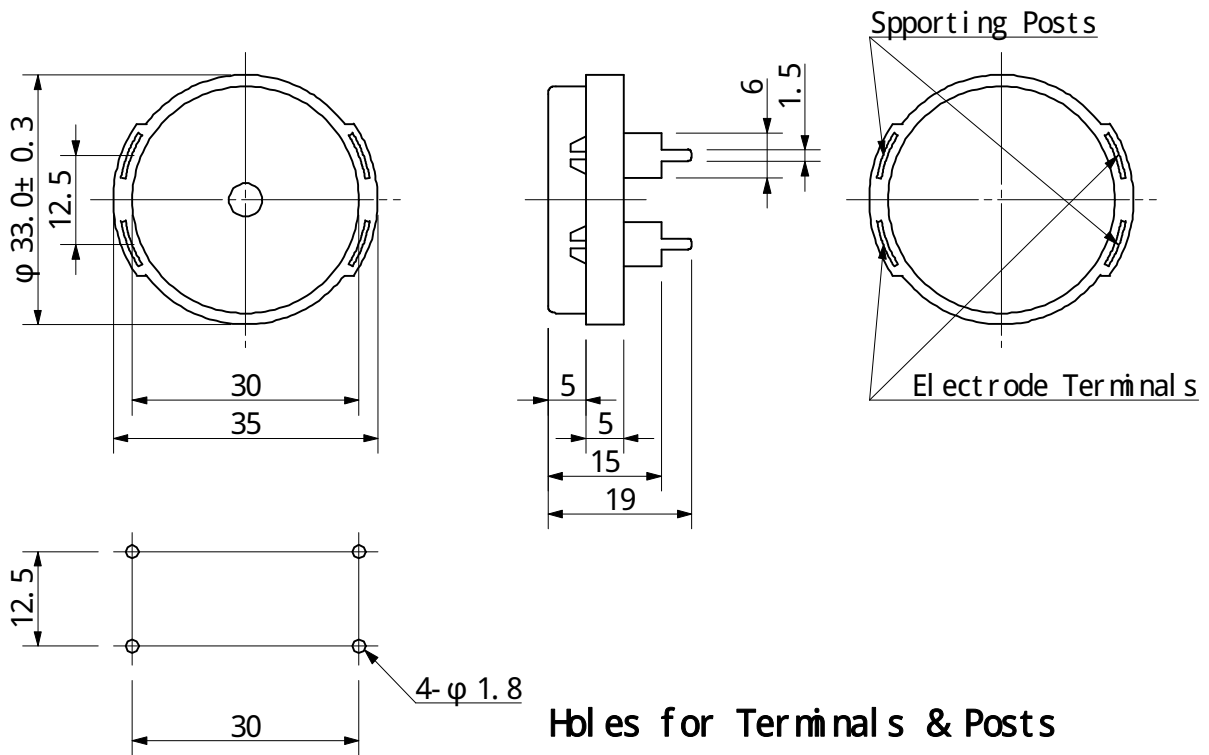

- 1) Case : PBT
- 2) Unit : mm

6. ENVIRONMENTAL CHARACTERISTICS

6-1. Moisture Storage.

Keep the element at the 40 +/- 2deg.C and 90 to 95%(R.H.) for 96 +/-5 hours.

Then, release the element into the room conditions for 12hours prior to the measurement.

It shall fulfill the specifications in Table 1.

6-2. High Temperature Storage.

Subject the element to 70+/-5deg.C for 96+/-5 hours. Then, release the element into the room conditions for 12hours prior to the measurement.

It shall fulfill the specifications in Table 1.

6-3. Low Temperature Storage.

Subject the element to -30+/-5deg.C for 96+/-5 hours. Then, release the element into the room conditions for 12hours prior to the measurement.

It shall fulfill the specifications in Table 1.

6-4. Temperature Cycle.

Subject the element to a low temperature of – 30deg.C for 30minuts, followed by a high temperature of + 70deg.C for 30minuts. Cycling shall be repeated 5times with a transfer time of 15minuts max. at the room temperature. Then, release the element into the room conditions for 12hours prior to the measurement.

It shall fulfill the specifications in Table 1.

Table 1.

Static Capacitance	Initial Value +/- 15 % MAX
Sound Pressure Level	Initial Value +/- 10 dB MAX

7. Remark

Not to be applied DC voltage.

8. The environment hazardous substance (RoHS Compliant Certificate)

This product is compliant with the European RoHS material requirements.

(Lead in this product is exempted from the RoHS requirement in the ANNEX.)