

SPECIFICATIONS

PARAMETERS	VALUES	UNIT
RATED VOLTAGE	3.6	Vp-p
OPERATING VOLTAGE RANGE	2.5 ~ 4.5	Vp-p
RATED CURRENT (MAX)	90	mA
COIL RESISTANCE	15 ± 3	OHM
MINIMUM SPL @ 10 CM	90	dBA
RESONANT FREQUENCY	2,630 ± 500	Hz
OPERATING TEMPERATURE	-30 ~ +70	°C
STORAGE TEMPERATURE	-40 ~ +85	°C
HOUSING MATERIAL	LCP	-
TERMINAL MATERIAL	Sn PLATED PHOSPHOR BRONZE	-
WEIGHT	0.39	grams

THIS DOCUMENT CONTAINS DATA PROPRIETARY TO PROJECTS UNLIMITED, INC. ANY USE OR REPRODUCTION, IN ANY FORM, WITHOUT PRIOR WRITTEN PERMISSION OF PROJECTS UNLIMITED, INC. IS PROHIBITED.
©2003, Projects Unlimited Inc.

REVISION HISTORY

LTR	DESCRIPTION	DATE	APPROVED
-	RELEASED FROM ENGINEERING	8/9/2005	
A	REVISED TO INVENTOR 3-D DRAWING TEMPLATE	5/3/2010	B.R.
B	UPDATE ROHS AND ADDED REFLOW NOTE	1/25/2019	M.L.

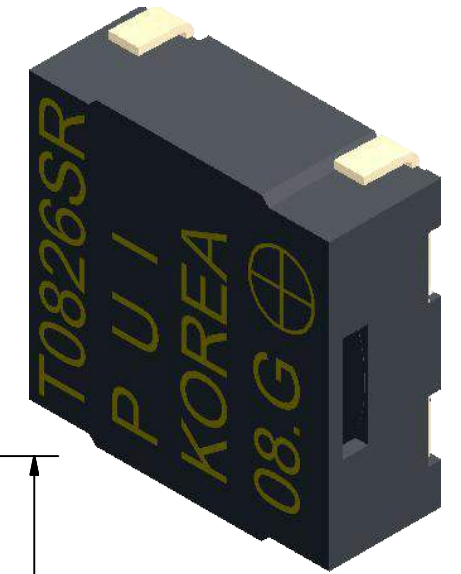
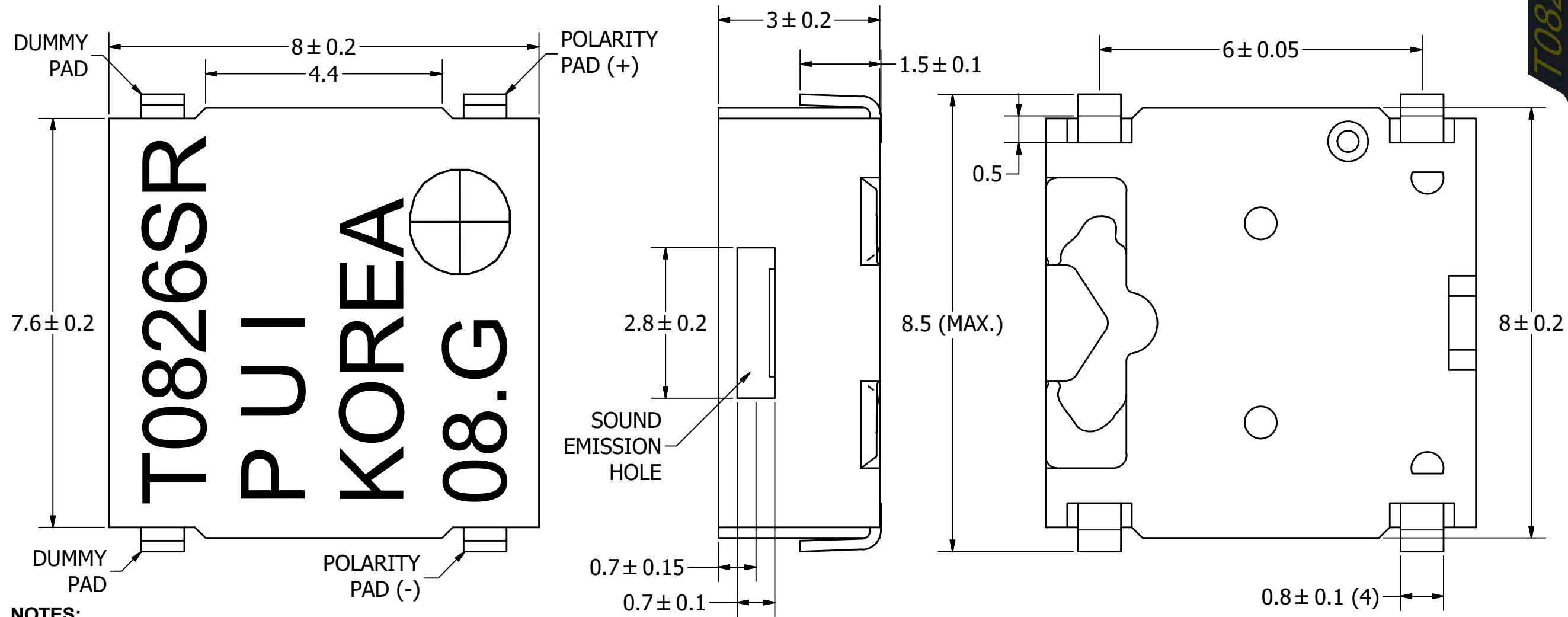

NOTES:

1. ALL DIMENSIONS ARE IN MILLIMETERS.
2. SPECIFICATIONS SUBJECT TO CHANGE OR WITHDRAWL WITHOUT NOTICE.
3. THIS PART IS RoHS 2011/65/EU COMPLIANT.
4. REFLOW ACCEPTABLE. MAX TEMP 260C, 10sec OR LESS.

UNLESS OTHERWISE SPECIFIED:	SIZE	Designed by	Date	Checked by	Date	Approved by	Date	Drawn Date	
DIMENSIONS ARE IN MILLIMETERS, TOLERANCES ARE ±0.5 AND ANGLES ARE ±3°.	A3	J.A.F.	8/9/2005	E.P.	8/9/2005	B.R.	8/9/2005	5/3/2010	
SMT-0826-S-R.idw				SMT-0826-S-R				Transducer (Electro-Mech)	
							Edition	Sheet	
							-	1 / 1	