

- NOTES:
- MATERIAL:
HOUSING: LCP, GLASS FILLED, UL94V-0. COLOR: BLACK;
FORKLOCK: COPPER ALLOY;
TERMINALS: COPPER ALLOY.
 - TERMINAL PLATING:
CONTACT AREA:
(a) GOLD FLASH(0.025 MICRONS MINIMUM);
(b) GOLD, THICKNESS=0.76 MICRONS MINIMUM;
(c) GOLD, THICKNESS=0.38 MICRONS MINIMUM;
SOLDER AREA: TIN, THICKNESS=2.00 MICRONS MINIMUM;
UNDER PLATE: NICKEL, THICKNESS=1.27 MICRONS MINIMUM.
 - FORLOCK PLATING:
SOLDER AREA: TIN, THICKNESS=2.00 MICRONS MINIMUM;
UNDER PLATING: NICKEL, THICKNESS=1.27 MICRONS MINIMUM.
 - PRODUCT SPECIFICATION: PS-67492-001.
 - PACKAGING METHOD: 47018-400*, TAPE REEL, DETAIL REFER TO PK-47018-003;
47018-210*, TAPE REEL, DETAIL REFER TO PK-47018-001;
OTHERS, TRAY, DETAIL REFER TO PK-67492-001.
 - MATING PARTS: 87703/87672.
 - PRODUCT COMPLIANT TO RoSH DIRECTIVE 2002/95/EC AND 2000/53/EC.

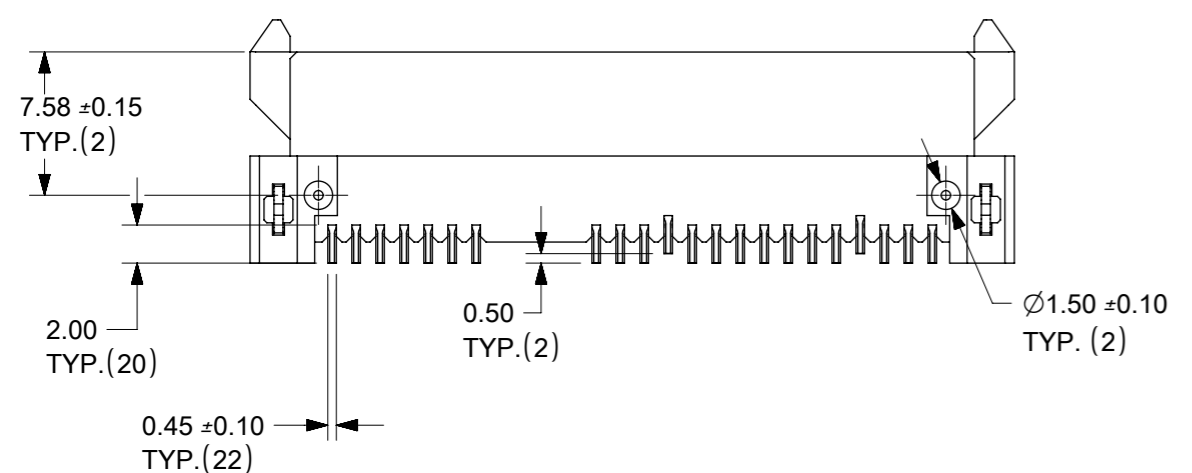

THIS DRAWING CONTAINS INFORMATION THAT IS PROPRIETARY TO MOLEX ELECTRONIC TECHNOLOGIES, LLC AND SHOULD NOT BE USED WITHOUT WRITTEN PERMISSION										
SYMBOLS		DIMENSION UNITS		SCALE		CURRENT REV DESC: MIGRATED TO NX				
▽ = 0	mm	2:1		molex SERIAL ATA DOCKING CONNECTOR TOP MOUNT TYPE PRODUCT CUSTOMER DRAWING DOCUMENT NUMBER: SD-47018-001 DOC TYPE: PSD DOC PART: 001 REVISION: M						
▽ = 0	GENERAL TOLERANCES (UNLESS SPECIFIED)									
▽ = 0		MM	INCH							
▽ = 0	4 PLACES	±	±							
▽ = 0	3 PLACES	±	±	EC NO: 615570	DRWN: GGUNAGI	2019/01/24	DRWN: GLLI 2011/12/12 APPR: XJSONG 2011/12/12			
▽ = 0	2 PLACES	± 0.25	±	CHK'D: JKACHLIC	2019/07/01					
▽ = 0	1 PLACE	± 0.25	±	APPR: JKACHLIC	2019/07/01					
▽ = 0	0 PLACES	±	±	INITIAL REVISION:			MATERIAL NUMBER: SEE SHEET 2			
▽ = 0	ANGULAR TOL ± 3.0°			THIRD ANGLE PROJECTION			DRAWING: A3-SIZE		SERIES: 47018	
▽ = 0	DRAFT WHERE APPLICABLE MUST REMAIN WITHIN DIMENSIONS			DRAWING: A3-SIZE		SERIES: 47018		CUSTOMER: GENERAL MARKET		SHEET NUMBER: 1 OF 2

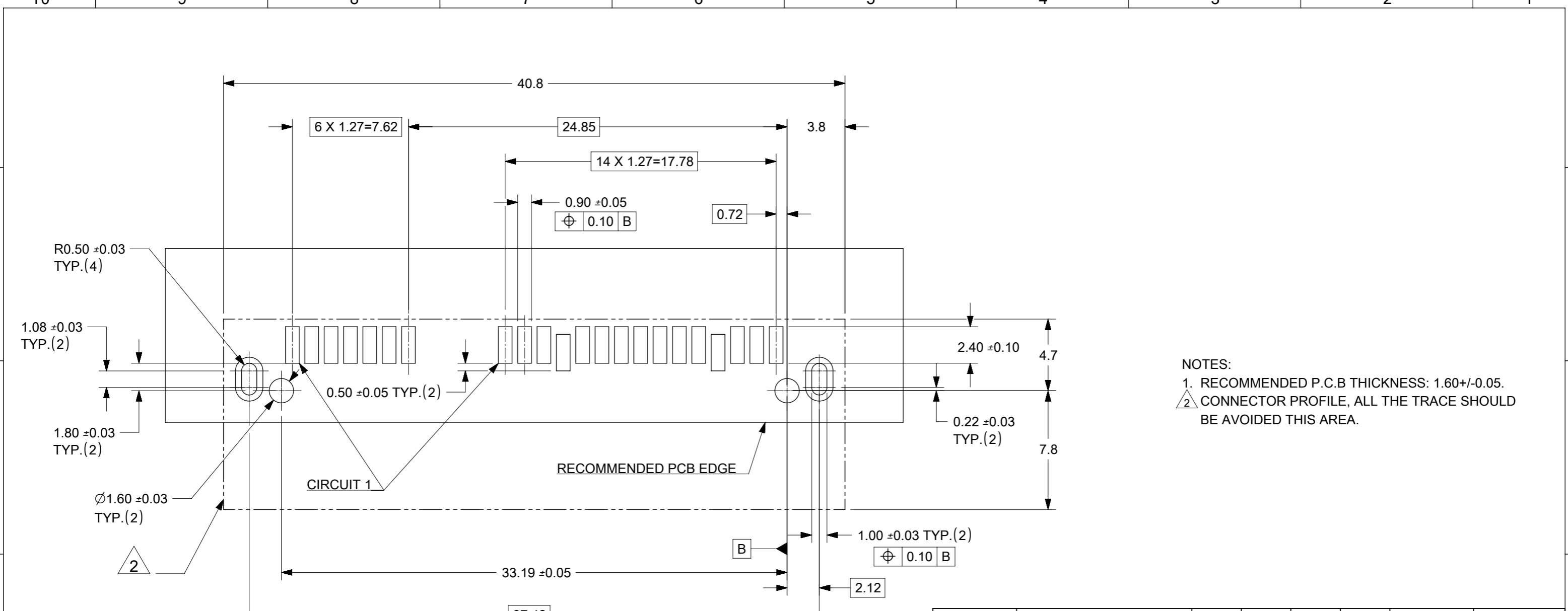

NOTES:
 1. RECOMMENDED P.C.B THICKNESS: 1.60+/-0.05.
 2. CONNECTOR PROFILE, ALL THE TRACE SHOULD BE AVOIDED THIS AREA.

RECOMMENDED P.C.B LAYOUT (COMPONENT SIDE)

PRODUCT	CONTACT PLATING SPEC	DIM'A'	DIM'B'	DIM'C'	DIM'D'	PACKAGE	REMARK
47018-2100	NOTES 2 (A) OF SHEET 1	2.55	4.30	9.65	3.65	TAPE REEL	PURE TIN (LIGHT TIN) WITH CAP
47018-2101	NOTES 2 (B) OF SHEET 1						
47018-2102	NOTES 2 (C) OF SHEET 1						
47018-4000	NOTES 2 (A) OF SHEET 1	3.40	5.15	10.50	4.50	TAPE REEL	PURE TIN (LIGHT TIN) WITH CAP
47018-4001	NOTES 2 (B) OF SHEET 1						
47018-4002	NOTES 2 (C) OF SHEET 1						
47018-2010	NOTES 2 (A) OF SHEET 1	2.55	4.30	9.65	3.65	TRAY	PURE TIN (MATTE TIN)
47018-2011	NOTES 2 (B) OF SHEET 1						
47018-2012	NOTES 2 (C) OF SHEET 1						
47018-2000	NOTES 2 (A) OF SHEET 1	2.55	4.30	9.65	3.65	TRAY	PURE TIN (LIGHT TIN)
47018-2001	NOTES 2 (B) OF SHEET 1						
47018-2002	NOTES 2 (C) OF SHEET 1						

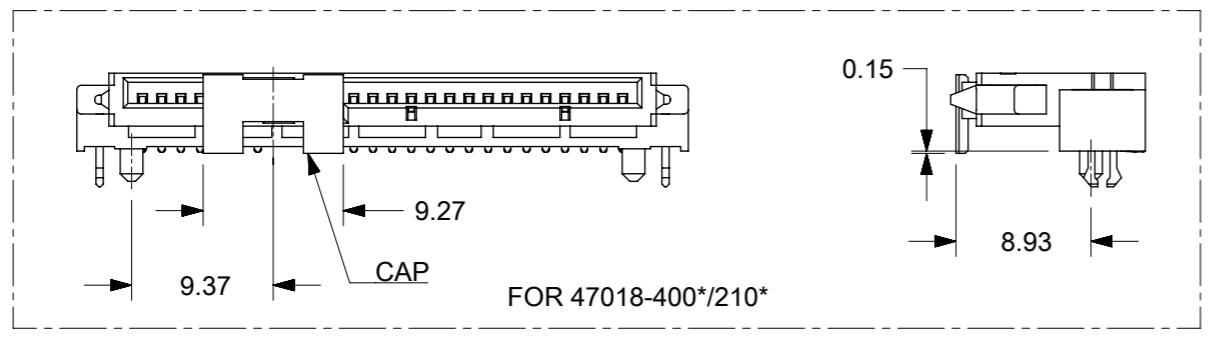

THIS DRAWING CONTAINS INFORMATION THAT IS PROPRIETARY TO MOLEX ELECTRONIC TECHNOLOGIES, LLC AND SHOULD NOT BE USED WITHOUT WRITTEN PERMISSION

SYMBOLS: $\nabla = 0$, $\nabla = 0$, $\nabla = 0$, $\nabla = 0$, $\nabla = 0$, $\nabla = 0$, $\nabla = 0$, $\nabla = 0$, $\nabla = 0$, $\nabla = 0$

DIMENSION UNITS: mm, INCH

SCALE: 1:1

GENERAL TOLERANCES (UNLESS SPECIFIED):

	MM	INCH
4 PLACES ±		
3 PLACES ±		
2 PLACES ±	0.25	
1 PLACE ±	0.25	
0 PLACES ±		
ANGULAR TOL	± 3.0°	

DRAFT WHERE APPLICABLE MUST REMAIN WITHIN DIMENSIONS

THIRD ANGLE PROJECTION

DRAWING: A3-SIZE

SERIES: 47018

CURRENT REV DESC: MIGRATED TO NX

EC NO: 615570

DRWN: GGUNAGI 2019/01/24

CHK'D: JKACHLIC 2019/07/01

APPR: JKACHLIC 2019/07/01

INITIAL REVISION:

DRWN: GLLI 2011/12/12

APPR: XJSONG 2011/12/12

molex

SERIAL ATA DOCKING CONNECTOR TOP MOUNT TYPE

PRODUCT CUSTOMER DRAWING

DOCUMENT NUMBER: SD-47018-001

DOC TYPE: PSD

DOC PART: 001

REVISION: M

MATERIAL NUMBER: SEE TABLE

CUSTOMER: GENERAL MARKET

SHEET NUMBER: 2 OF 2