

Datasheet

Self-contained, dc-operated sensors

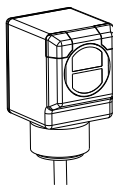

WARNING: Not To Be Used for Personnel Protection

Never use this device as a sensing device for personnel protection. Doing so could lead to serious injury or death. This device does not include the self-checking redundant circuitry necessary to allow its use in personnel safety applications. A sensor failure or malfunction can cause either an energized or de-energized sensor output condition.

Models

Model ¹	Sensing Mode	Range	LED	Output
Q406E	 OPPOSED	60 m (200 ft)	Infrared, 950 nm	-
Q40SN6R				NPN
Q40SP6R				PNP
Q40SN6LP	 POLAR RETRO	6 m (20 ft)	Visible red, 680 nm	NPN
Q40SP6LP				PNP
Q40SN6FF200	 FIXED-FIELD	200 mm (8 in) cutoff	Infrared, 880 nm	NPN
Q40SP6FF200				PNP
Q40SN6FF400		400 mm (16 in) cutoff		NPN
Q40SP6FF400				PNP
Q40SN6FF600		600 mm (24 in) cutoff		NPN
Q40SP6FF600				PNP

Fixed-Field Mode Overview

Q40 Series self-contained fixed-field sensors are small, powerful, infrared diffuse mode sensors with far-limit cutoff. The high excess gain of these sensors makes it possible for them to detect objects of low reflectivity. The fixed-field design makes them ideal for detecting a part or surface that is directly in front of another surface, while ignoring the surface in the background.

Installation

In the drawings and discussion in [Excess Gain](#) on page 4 and in [Background Reflectivity and Placement](#) on page 2, the letters E, R1, and R2 identify how the sensor's three optical elements (Emitter "E," Near Detector "R1," and Far Detector "R2") line up across the face of the sensor. In [Figure 1](#) on page 2, [Figure 2](#) on page 2, and [Figure 3](#) on page 2, these elements align vertically; in [Figure 4](#) on page 2, they align horizontally. Note how the pattern on the sensor's lens helps to define the sensing axis of the sensor ([Figure 6](#) on page 4). The sensing axis becomes important in situations like those illustrated in [Figure 3](#) on page 2 and [Figure 4](#) on page 2.

¹ Standard 2 m (6.5 ft) cable models are listed.

- To order 9 m (30 ft) cable: add suffix "W/ 30" (for example, Q406E W/ 30).
- To order 4-pin Euro-style QD models: add suffix "Q" (for example, Q406EQ). A model with a QD connector requires a mating cable.



Background Reflectivity and Placement

Avoid mirror-like backgrounds that produce specular reflections. A false sensor response occurs if a background surface reflects the sensor's light more to the near detector (R1) than to the far detector (R2). The result is a false ON condition (Figure 1 on page 2). To correct this problem, use a diffusely reflective (matte) background, or angle either the sensor or the background (in any plane) so the background does not reflect light back to the sensor (see Figure 2 on page 2). Position the background as far beyond the cutoff distance as possible.

An object beyond the cutoff distance, either stationary (and when positioned as shown in Figure 3 on page 2), or moving past the face of the sensor in a direction perpendicular to the sensing axis, may cause unwanted triggering of the sensor if more light is reflected to the near detector than to the far detector. The problem is easily remedied by rotating the sensor 90° (Figure 4 on page 2) to align the sensing axis horizontally. The object then reflects the R1 and R2 fields equally, resulting in no false triggering. A better solution, if possible, may be to reposition the object or the sensor.

Unwanted triggering of the sensor from an object beyond the cutoff can also be caused by attempting to sense a small object that is moving perpendicular to the sensor face, or by an object moving through the off-center position shown in Figure 3 on page 2. Making the object larger, centering the sensor relative to the object, or rotating the sensor to place the sensing axis perpendicular to the longer dimension of the object (Figure 4 on page 2) will solve the problem.

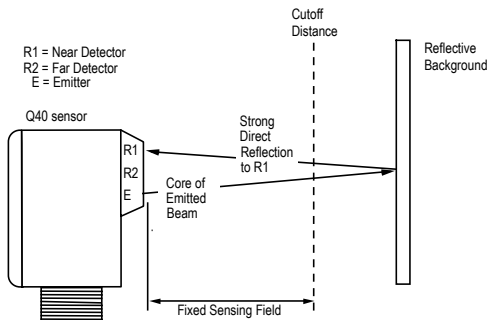

Figure 1. Reflective background - problem

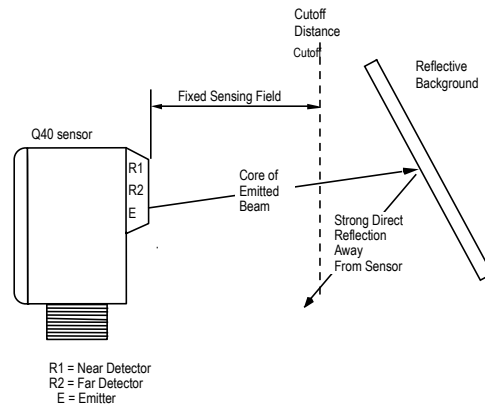

Figure 2. Reflective background - solution

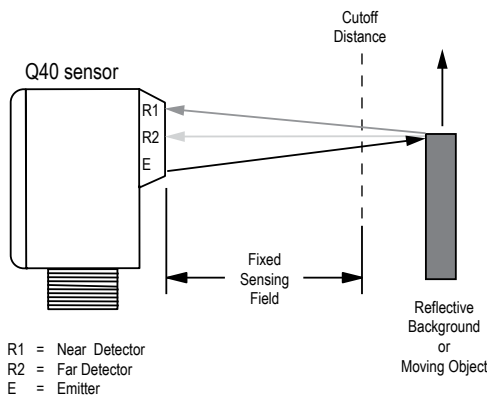

Figure 3. Object beyond cutoff - problem

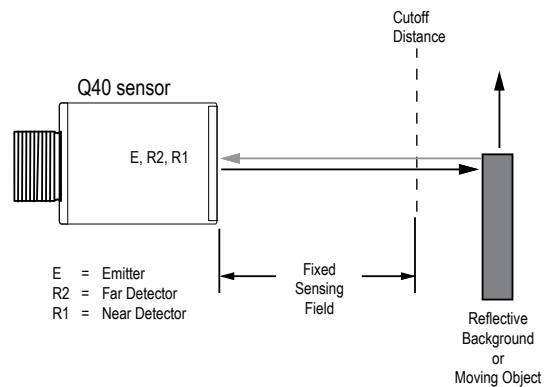
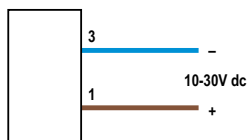

Figure 4. Object beyond cutoff - solution

Wiring Diagrams

Cabled Emitters



NPN (Sinking) Outputs
Standard Hookup

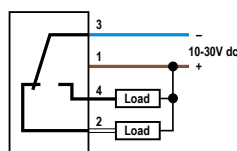

PNP (Sourcing) Outputs
Standard Hookup

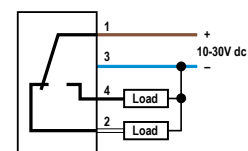



NOTE: QD hookups are functionally identical.

Alarm Hookup

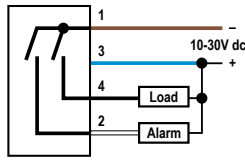

Alarm Hookup

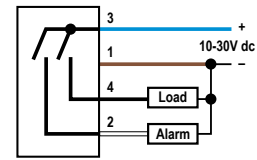

Specifications

Supply Voltage and Current

- 10 to 30 V dc (10% max. ripple)
- Supply current (exclusive of load current):
- Emitters: 25 mA
- Receivers: 20 mA
- Polarized Retroreflective: 30 mA
- Fixed-Field: 35 mA

Supply Protection Circuitry

Protected against reverse polarity and transient voltages

Output Configuration

- SPDT solid-state dc switch; Choose NPN (current sinking) or PNP (current sourcing) models
- Light Operate:* N.O. output conducts when sensor sees its own (or the emitter's) modulated light
- Dark Operate:* N.C. output conducts when the sensor sees dark; the N.C. (normally closed) output may be wired as a normally open marginal signal alarm output, depending upon hookup to power supply (U.S. patent 5087838)

Output Rating

- 150 mA maximum (each) in standard hookup.
- When wired for alarm output, the total load may not exceed 150 mA.
- OFF-state leakage current: < 1 microamp at 30 V dc
- ON-state saturation voltage: < 1V at 10 mA dc; < 1.5 V at 150 mA dc

Required Overcurrent Protection



WARNING: Electrical connections must be made by qualified personnel in accordance with local and national electrical codes and regulations.

- Overcurrent protection is required to be provided by end product application per the supplied table.
- Overcurrent protection may be provided with external fusing or via Current Limiting, Class 2 Power Supply.
- Supply wiring leads < 24 AWG shall not be spliced.
- For additional product support, go to www.bannerengineering.com.

Supply Wiring (AWG)	Required Overcurrent Protection (Amps)
20	5.0
22	3.0
24	2.0
26	1.0
28	0.8
30	0.5

Output Protection Circuitry

Protected against false pulse on power-up and continuous overload or short circuit of outputs

Output Response Time

- Opposed mode: 3 ms ON, 1.5 ms OFF
- Retro and Fixed-Field: 3 ms ON and OFF



NOTE: 100 ms delay on power-up; outputs do not conduct during this time.

Repeatability

- Opposed mode: 375 μ s
- Retro and Fixed-Field: 750 μ s
- Repeatability and response are independent of signal strength

Indicators

- Two LEDs (Green and Amber)
- Green ON steady: power to sensor is ON
- Green flashing: output is overloaded
- Amber ON steady: N.O. output is conducting
- Amber flashing: excess gain marginal (1 to 1.5x) in light condition

Construction

PBT polyester housing; acrylic lens

Environmental Rating

Leakproof design rated NEMA 6P, IEC IP67. QD Models rated IEC IP69K per DIN 40050-9.

Connections

2 m (6.5 ft) or 9 m (30 ft) attached cable, or 4-pin Euro-style quick-disconnect fitting

Operating Conditions

- Temperature: -40 °C to +70 °C (-40 °F to +158 °F)
- 90% at +50 °C maximum relative humidity (non-condensing)

Vibration and Mechanical Shock

All models meet Mil. Std. 202F requirements. Method 201A (Vibration; frequency 10 Hz to 60 Hz, max., double amplitude 0.06 inch acceleration 10G). Method 213B conditions H&I. Shock: 75G with unit operating; 100G for non-operation

Certifications



Dimensions

Cabled Models

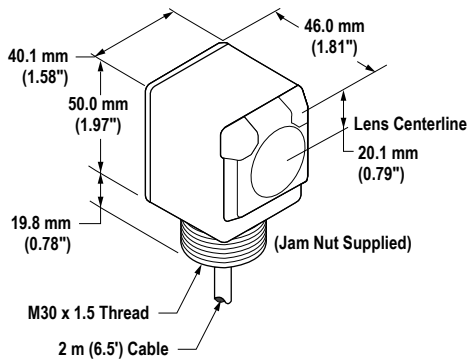

QD Models

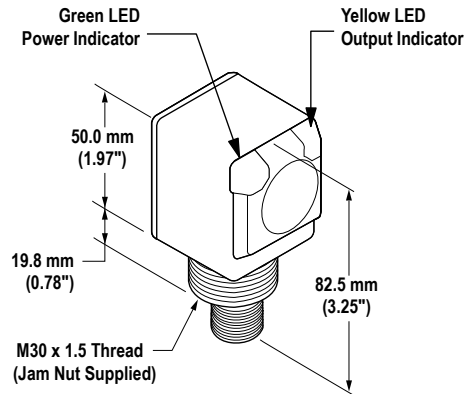

All measurements are listed in millimeters [inches], unless noted otherwise.

Excess Gain

The excess gain curves for these products are available on the Banner website. They show excess gain versus sensing distance for sensors with 200 mm, 400 mm, and 600 mm (8 in, 16 in, and 24 in) cutoffs. Maximum excess gain for all models occurs at a lens-to-object distance of about 40 mm (1.57 in). Sensing at or near this distance makes maximum use of each sensor's available sensing power.

Backgrounds and background objects must always be placed beyond the cutoff distance.

The excess gain curves were generated using a white test card of 90% reflectance. Objects with reflectivity of less than 90% reflect less light back to the sensor, and thus require proportionately more excess gain in order to be sensed with the same reliability as more reflective objects. When sensing an object of very low reflectivity, it may be especially important to sense it at or near the distance of maximum excess gain.

The effects of object reflectivity on cutoff distance, though small, may be important for some applications. Sensing of objects of less than 90% reflectivity causes the cutoff distances to be "pulled" slightly closer to the sensor. For example, an excess gain of 1 for an object that reflects 1/10 as much light as the 90% white card is represented by the heavy horizontal graph line at excess gain = 10. An object of this reflectivity results in far limit cutoffs of approximately 190 mm, 250 mm, and 390 mm (7.48 in, 9.84 in, and 15.4 in) for the 200 mm, 400 mm, and 600 mm (8 in, 16 in, and 24 in) cutoff models, respectively.

For highest sensitivity, the sensor-to-object distance should be such that the object will be sensed at or near the point of maximum excess gain. The background must be placed beyond the cutoff distance. Following these two guidelines makes it possible to detect objects of low reflectivity, even against close-in reflective backgrounds.

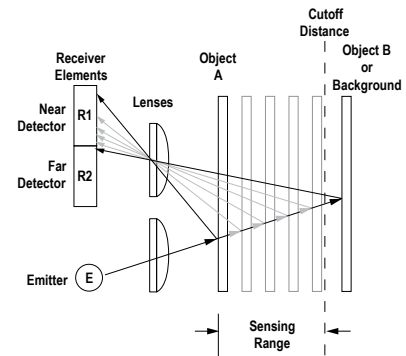

Object is sensed if amount of light at R1 is greater than the amount of light at R2

Figure 5. Fixed-field Concept

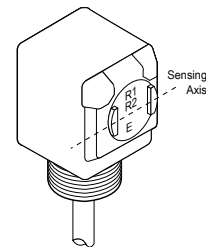

As a general rule, the most reliable sensing of an object approaching from the side occurs when the line of approach is parallel to the sensing axis.

Figure 6. Fixed-field sensing axis

Quick-Disconnect (QD) Cables

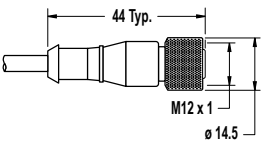
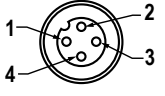
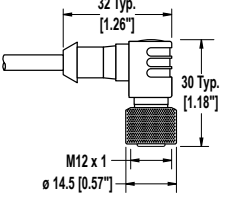
4-Pin Threaded M12/ Euro-Style Cordsets				
Model	Length	Style	Dimensions	Pinout (Female)
MQDC-406	1.83 m (6 ft)	Straight		 <p>1 = Brown 2 = White 3 = Blue 4 = Black</p>
MQDC-415	4.57 m (15 ft)			
MQDC-430	9.14 m (30 ft)			
MQDC-450	15.2 m (50 ft)			
MQDC-406RA	1.83 m (6 ft)	Right-Angle		
MQDC-415RA	4.57 m (15 ft)			
MQDC-430RA	9.14 m (30 ft)			
MQDC-450RA	15.2 m (50 ft)			

Banner Engineering Corp. Limited Warranty

Banner Engineering Corp. warrants its products to be free from defects in material and workmanship for one year following the date of shipment. Banner Engineering Corp. will repair or replace, free of charge, any product of its manufacture which, at the time it is returned to the factory, is found to have been defective during the warranty period. This warranty does not cover damage or liability for misuse, abuse, or the improper application or installation of the Banner product.

THIS LIMITED WARRANTY IS EXCLUSIVE AND IN LIEU OF ALL OTHER WARRANTIES WHETHER EXPRESS OR IMPLIED (INCLUDING, WITHOUT LIMITATION, ANY WARRANTY OF MERCHANTABILITY OR FITNESS FOR A PARTICULAR PURPOSE), AND WHETHER ARISING UNDER COURSE OF PERFORMANCE, COURSE OF DEALING OR TRADE USAGE.

This Warranty is exclusive and limited to repair or, at the discretion of Banner Engineering Corp., replacement. IN NO EVENT SHALL BANNER ENGINEERING CORP. BE LIABLE TO BUYER OR ANY OTHER PERSON OR ENTITY FOR ANY EXTRA COSTS, EXPENSES, LOSSES, LOSS OF PROFITS, OR ANY INCIDENTAL, CONSEQUENTIAL OR SPECIAL DAMAGES RESULTING FROM ANY PRODUCT DEFECT OR FROM THE USE OR INABILITY TO USE THE PRODUCT, WHETHER ARISING IN CONTRACT OR WARRANTY, STATUTE, TORT, STRICT LIABILITY, NEGLIGENCE, OR OTHERWISE.

Banner Engineering Corp. reserves the right to change, modify or improve the design of the product without assuming any obligations or liabilities relating to any product previously manufactured by Banner Engineering Corp. Any misuse, abuse, or improper application or installation of this product or use of the product for personal protection applications when the product is identified as not intended for such purposes will void the product warranty. Any modifications to this product without prior express approval by Banner Engineering Corp will void the product warranties. All specifications published in this document are subject to change; Banner reserves the right to modify product specifications or update documentation at any time. Specifications and product information in English supersede that which is provided in any other language. For the most recent version of any documentation, refer to: www.bannerengineering.com.