

R-Rated medium voltage fuses for motor circuit protection



Description:

- Indoor/enclosure, R-Rated medium voltage, current-limiting fuses for motor circuit protection.

Features and benefits

- Current-limiting R-Rated fuses will safely interrupt all currents between their minimum and maximum interrupting ratings and will melt in a range of 15 to 35 seconds at a value of 100 times the “R” number per ANSI C37.46.
- R-Rated fuses are physically dimensioned for easy installation in existing hardware.
- Available in standard, AMPGARD Hookeye and hermetically sealed, and bolt-on mounting styles to meet application needs.
- 4.8 kV Limitamp® bolt-on constructions available in ratings from 2R to 24R.
- 2.4 kV and 4.8 kV AMPGARD hermetically sealed constructions are suitable for Class I, Group D, Div. 2 hazardous locations.
- Open fuse indicator on all mounting styles speeds troubleshooting.
- Classified as backup fuses for current-limiting protection of medium voltage motor controllers (short-circuit performance only).
- These fuses are in a self-contained, non-venting package for installation indoors or outdoors in an enclosure.

Typical applications:

- Medium voltage motors and controllers

Contents

Description	Page	Description	Page
2.4 kV R-Rated fuses	2-7	7.2 kV R-Rated fuses	18-22
Introduction	2	Introduction	18
Catalog numbers	3	Catalog numbers	18
Curves	4-7	Curves	20-22
4.8 kV R-Rated fuses	8-17		
Introduction	8		
Catalog numbers	9		
Curves	11-17		

2.4 kV R-Rated fuses

Catalog symbols:

Code-(amps)R	Construction
JCK-R	Standard
2CLS-R	
JCK-A-R*	AMPGARD Hookeye
2ACLS-R	
JCH-R	Hermetically sealed AMPGARD
2HCLS-R	
JCK-B-R	Bolt-on
2BCLS-R	

* For use in 400 amp AMPGARD motor starters.

Ratings:

- Volts
 - 2.4 kV (nominal)
 - 2.54 kV (max design)
- Amps 25-450 A
- Interrupting ratings
 - 50 kA Sym
 - 80 kA Asym

Agency information:

- UL Recognized: Guide MSSS2, File E96676 (JCK-R [2R-12R] and JCK-A-R [2R-12R])

Recommended fuse holders for standard constructions:

Amp range	Description	Cat. No.
Fuseclips		
25-230A	3" Enclosed fuseclip*	A3354730
25-450A	3" Open fuseclip	1A0065
	3" Spring loaded open fuseclip	9078A67G04
Fuse holders		
25-230A	Non-disconnect holder, porcelain	2CLE-PNM-D
	Non-disconnect holder, glass polyester	2CLE-GNM-D
	Disconnect holder, porcelain	2CLE-PDM-D
	Disconnect holder, glass polyester	2CLE-GDM-E
390-450A	Non-disconnect holder, porcelain	2CLE-PNM-E
	Non-disconnect holder, glass polyester	2CLE-GNM-E
Double barrel	Disconnect holder, porcelain	2CLE-PDM-E
	Disconnect holder, glass polyester	2CLE-GDM-E

* Single barrel only, not sold in pairs.

Dimensions - in [mm]

Construction	Amp range	Dimension			
		A	B	C	D
Standard - short	25-230A	10.8 (274)	3 (76)	3 (76)	—
	390-450A				3.3 (84)
AMPGARD Hookeye*	70-230A	19.2 (488)	17.9 (455)	3 (76)	—
	390-450A				3.3 (84)
Bolt-on	25-230A	19.2 (488)	17.9 (455)	3 (76)	—
	390-450A				3.3 (84)

* Includes hermetically sealed versions.

Standard and AMPGARD Hookeye

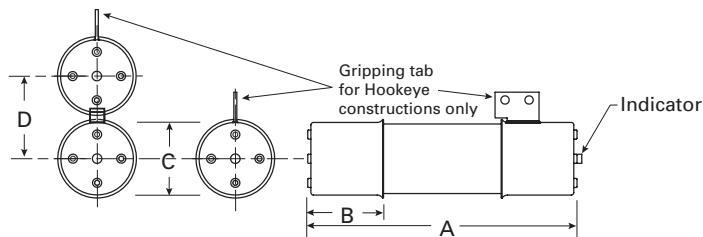

Bolt-on

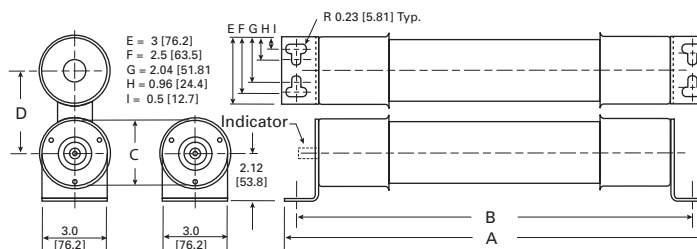

2.4 kV R-Rated fuse catalog numbers

"R"		Mounting style (minimum interrupting rating in amps)								No. of barrels
Amps	Des.	Standard		Standard AMPGARD		Hermetically sealed AMPGARD		Bolt-on		
25	—	—	2CLS-25* (100)	—	2ACLS-25* (90)	JCH-30* (90)	2HCLS-25* (90)	JCK-B-25* (90)	2BCLS-25* (90)	1
70	2R	JCK-2R (165)	2CLS-2R (180)	JCK-A-2R (165)	2ACLS-2R (180)	JCH-2R (180)	2HCLS-2R (180)	JCK-B-2R (180)	2BCLS-2R (180)	
100	3R	JCK-3R (220)	2CLS-3R (270)	JCK-A-3R (220)	2ACLS-3R (270)	JCH-3R (270)	2HCLS-3R (270)	JCK-B-3R (270)	2BCLS-3R (270)	
130	4R	JCK-4R (320)	2CLS-4R (360)	JCK-A-4R (320)	2ACLS-4R (360)	JCH-4R (360)	2HCLS-4R (360)	JCK-B-4R (360)	2BCLS-4R (360)	
150	5R	JCK-5R (410)	2CLS-5R (450)	JCK-A-5R (410)	2ACLS-5R (450)	JCH-5R (450)	2HCLS-5R (450)	JCK-B-5R (450)	2BCLS-5R (450)	
170	6R	JCK-6R (480)	2CLS-6R (540)	JCK-A-6R (480)	2ACLS-6R (540)	JCH-6R (540)	2HCLS-6R (540)	JCK-B-6R (540)	2BCLS-6R (540)	
200	9R	JCK-9R (720)	2CLS-200* (740)	JCK-A-9R (720)	2ACLS-200* (740)	JCH-200* (740)	2HCLS-200* (740)	JCK-B-200* (740)	2BCLS-200* (740)	
230	12R	JCK-12R (970)	2CLS-230* (1080)	JCK-A-12R (970)	2ACLS-230* (1080)	JCH-230* (1080)	2HCLS-230* (1080)	JCK-B-230* (1080)	2BCLS-230* (1080)	
390	18R	JCK-18R (1430)†	2CLS-390* (1500)	JCK-A-18R (1430)†	2ACLS-390* (1500)	JCH-390* (1500)	2HCLS-390* (1500)	JCK-B-390* (1500)	2BCLS-390* (1500)	
450	24R	JCK-24R (1880)†	2CLS-450* (2200)	JCK-A-24R (1880)†	2ACLS-450* (2200)	JCH-450* (2200)	2HCLS-450* (2200)	JCK-B-450* (2200)	2BCLS-450* (2200)	

* Does not comply with ANSI C37.46 for "R" rating.
† Not UL

JCK and 2HCLS Type mountings -in (mm)

Catalog number	Hole centers		Overall length C	Hole Inset D	Hole centers E	Contact height F	Overall height G	BIL (kV)
	A	B						
Disconnect single barrel†								
2CLE-GDM-D	8.24 (209.3)	6 (152.4)	18 (457.2)	0.62 (15.7)	1.75 (44.4)	4.5 (114.3)	11.72 (297.7)	60
2CLE-PDM-D								
Disconnect double barrel†								
2CLE-GDM-E	8.24 (209.3)	6 (152.4)	18 (457.2)	0.62 (15.7)	1.75 (44.4)	4.5 (114.3)	15.28 (388.1)	60
2CLE-PDM-E								
Non-disconnect single barrel								
2CLE-GNM-D	8.24 (209.3)	6 (152.4)	18 (457.2)	0.62 (15.7)	1.75 (44.4)	4.5 (114.3)	8.79 (223.3)	60
2CLE-PNM-D								
Non-disconnect double barrel								
2CLE-GNM-E	8.24 (209.3)	6 (152.4)	18 (457.2)	0.62 (15.7)	1.75 (44.4)	4.5 (114.3)	12.48 (317.0)	60
2CLE-PNM-E								

2.4 kV disconnect mounting†

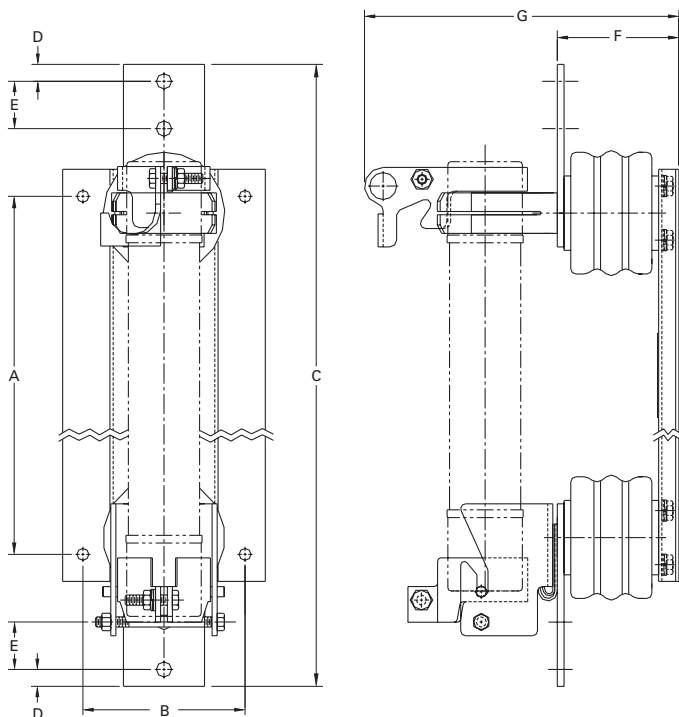

2.4 kV non-disconnect mounting

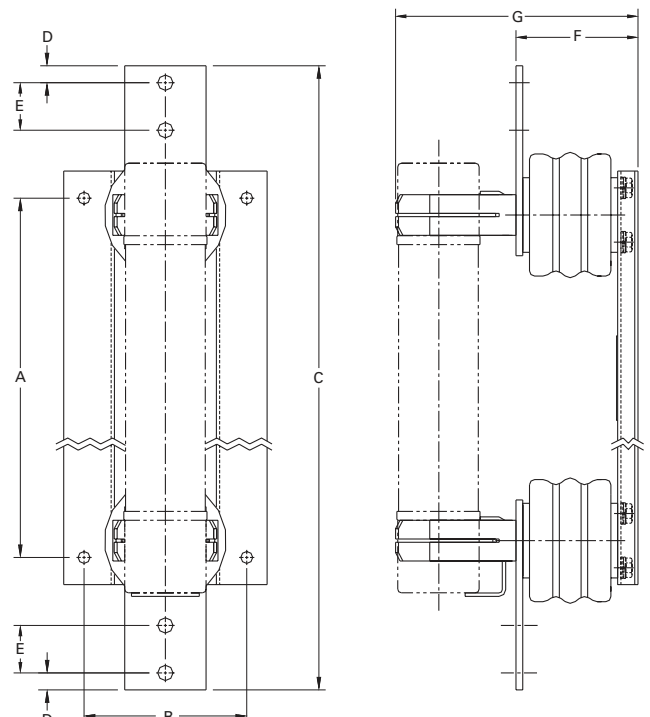

† Disconnect mountings provide a means for fuse extraction only. Do not use a disconnect mounting for load switching or fuse removal while energized.

2.4 kV Time-current curves — minimum melting for 2HCLS-_R and 2BCLS-_R (25A, 2R-24R @25°C)

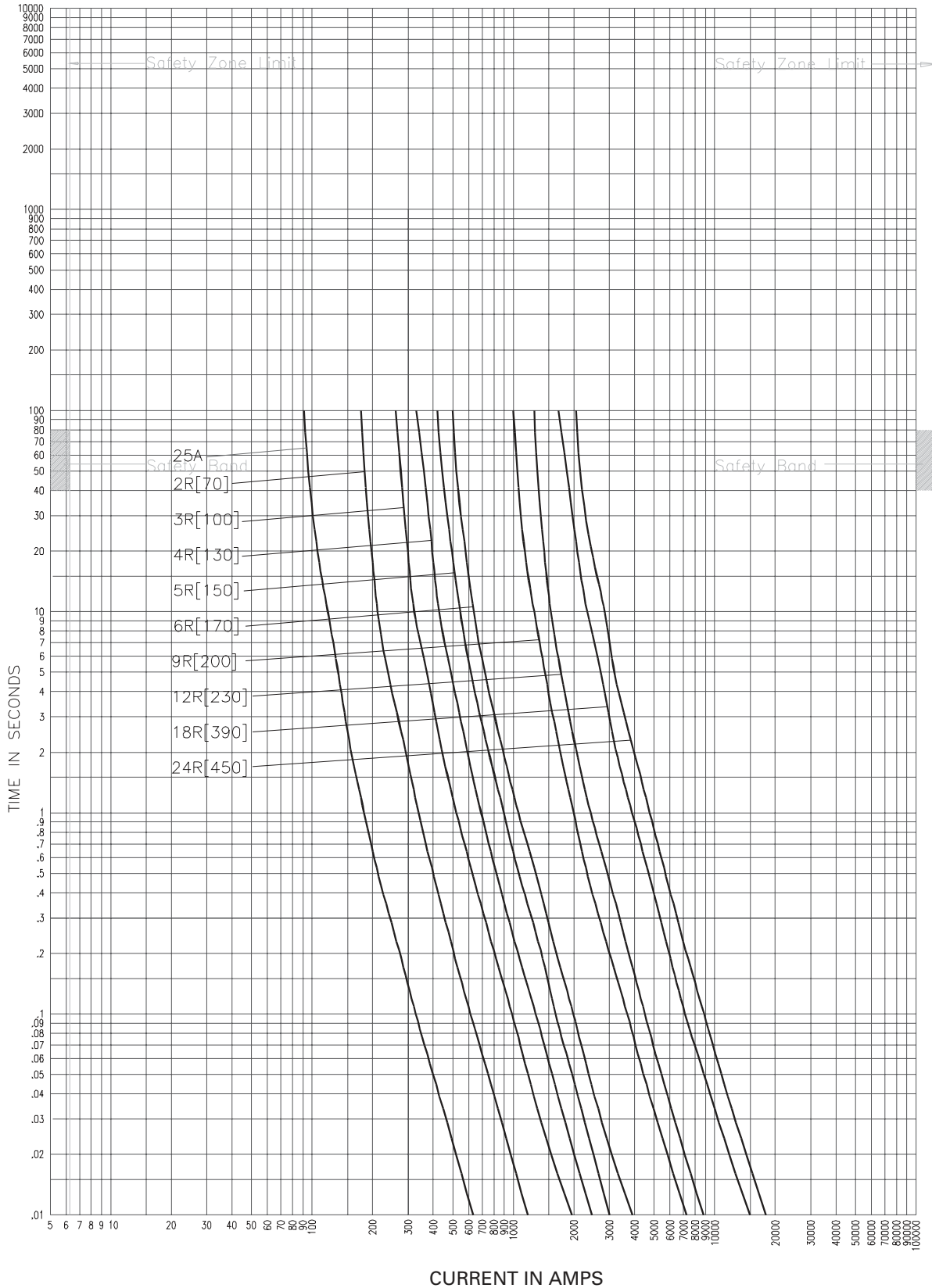

2HCLS-_R and 2BCLS-_R

CURVE 66664702
January 2001
Reference # 666647,
512853, 639405

2.4 kV Time-current curves — total clearing for 2HCLS-_R and 2BCLS-_R (25A, 2R-24R @25°C)

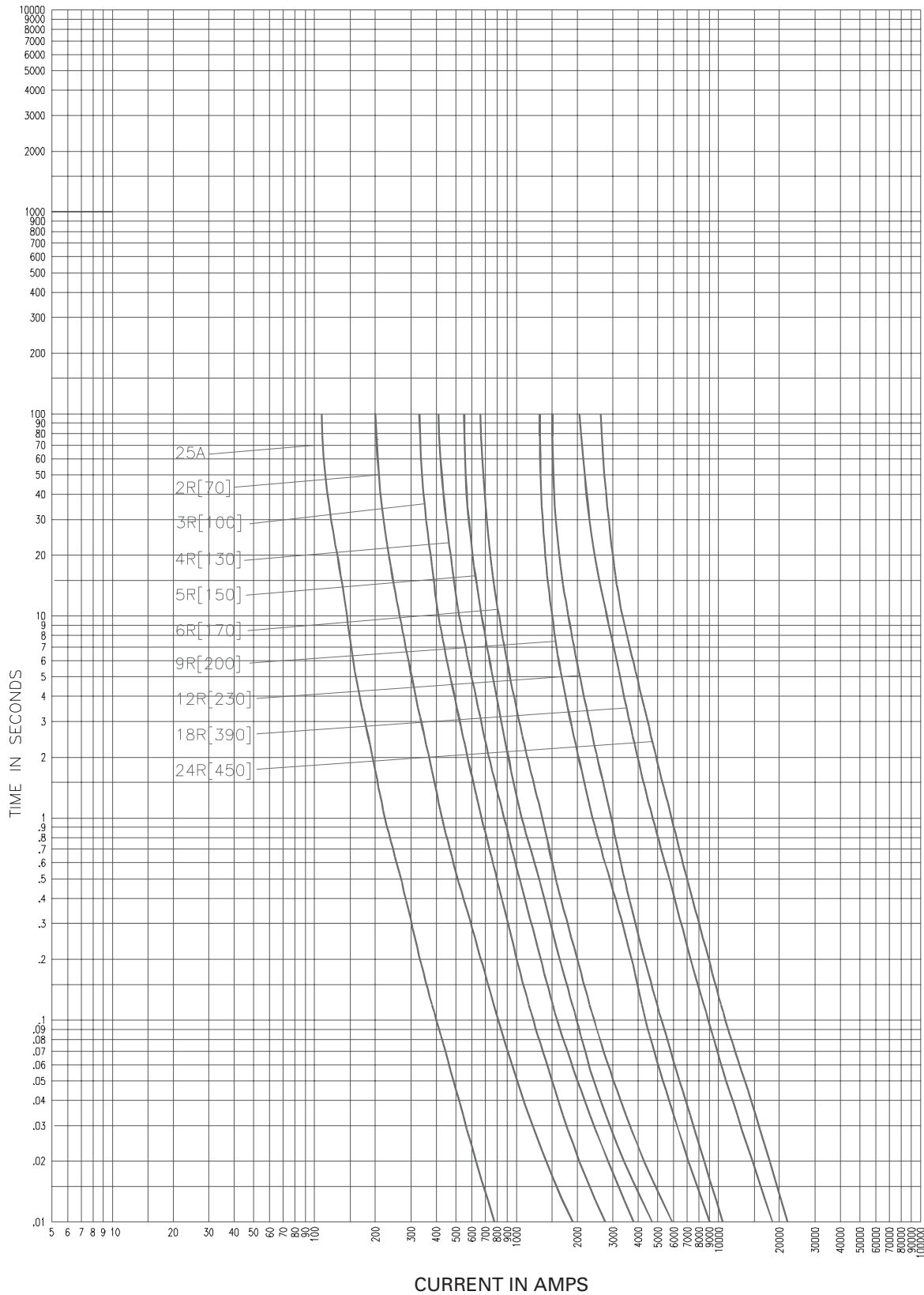

2HCLS-_R and 2BCLS-_R

CURVE 66664704
January 2000
Reference # 666647,
512854, 639406

2.4 kV Peak let-through curves for 2HCLS-_R and 2BCLS-_R (25A, 2R-24R @25°C)

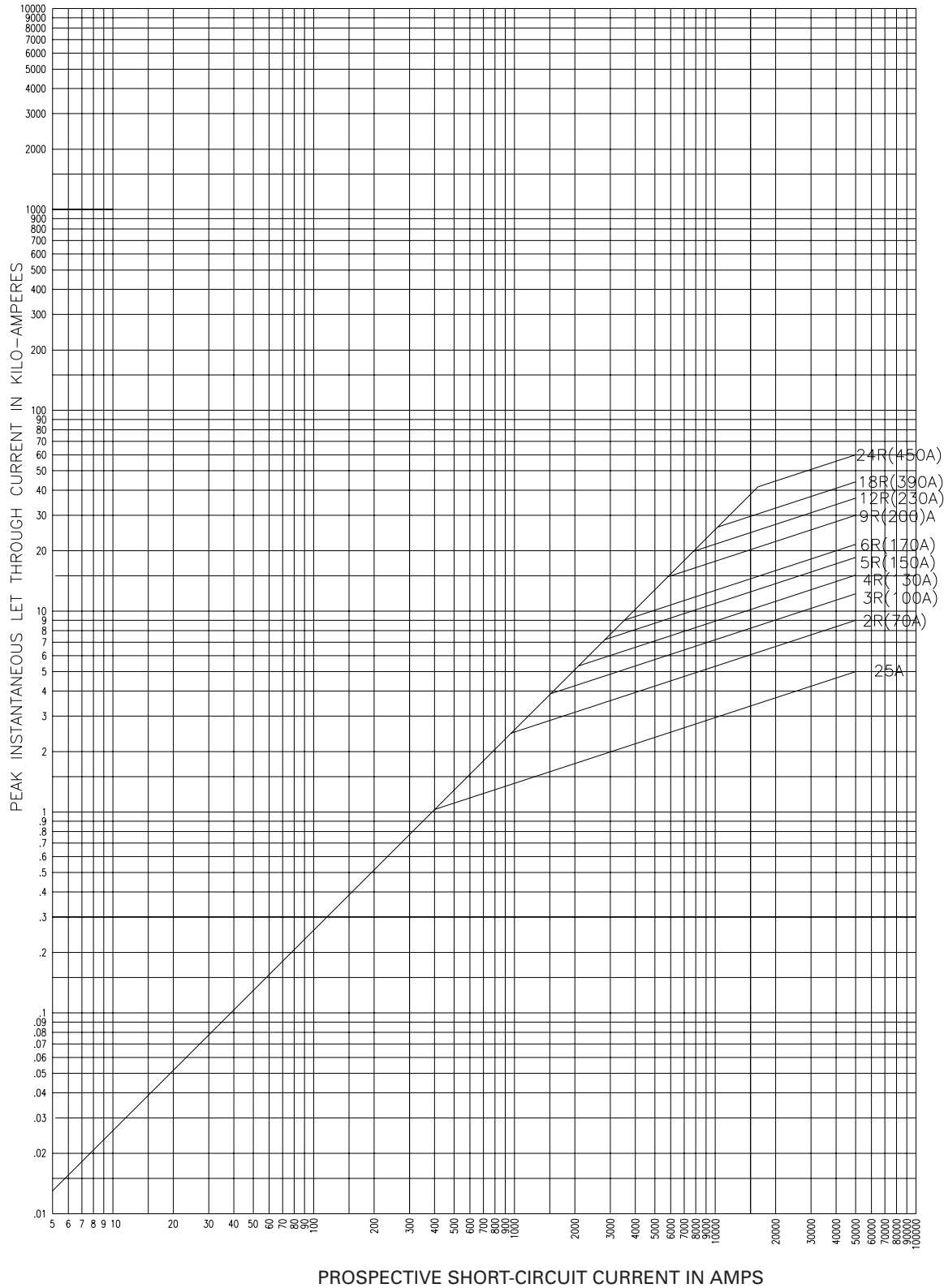

2HCLS-_R and 2BCLS-_R

CURVE 66700202
January 2001
Reference # 639315

2.4 kV Time-current curves — minimum melting for JCK-_R and JCK-A-_R (2R-24R @25°C)

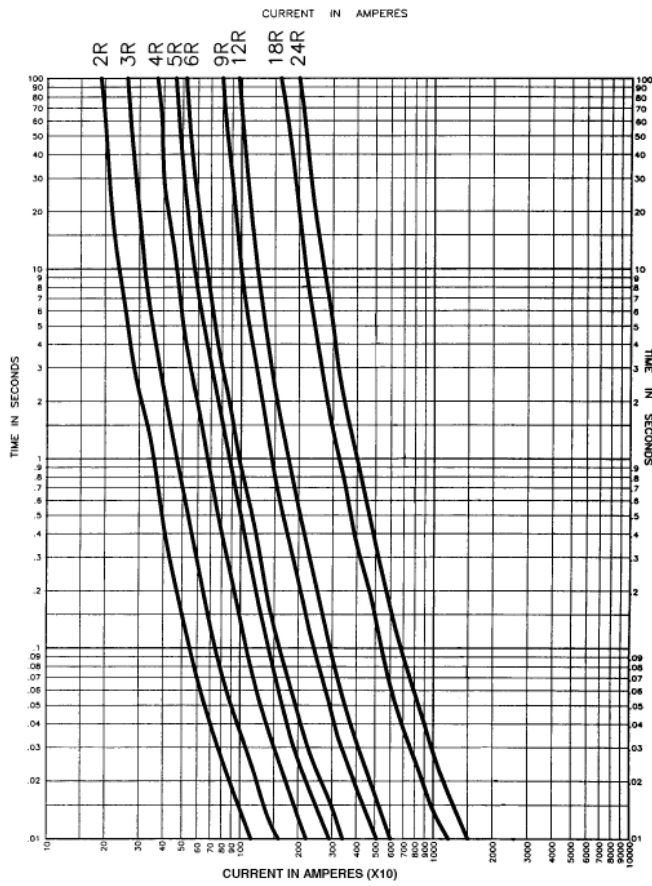

2.4 kV Time-current curves — total clearing for JCK-_R and JCK-A-_R (2R-24R @25°C)

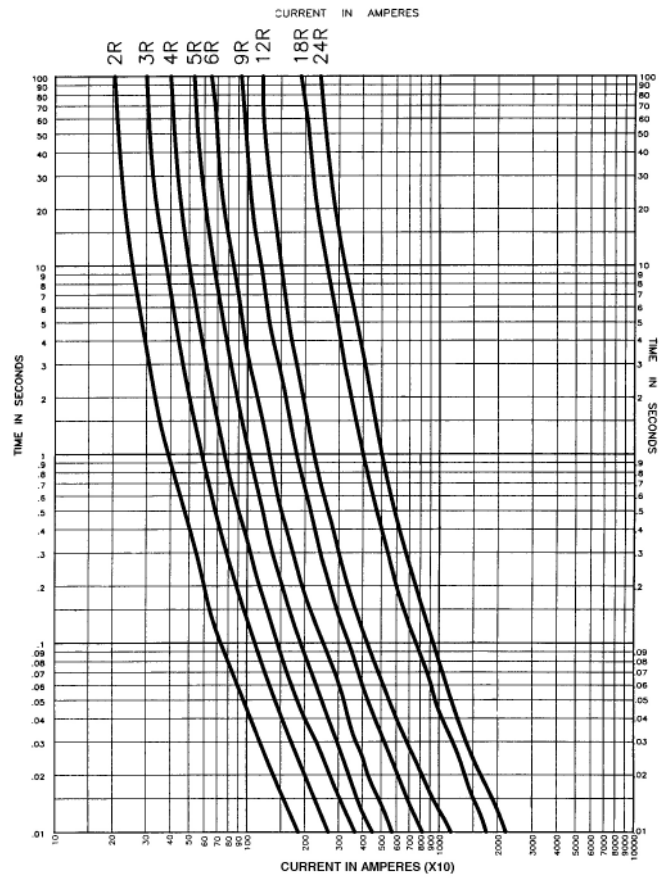

2.4 kV Peak let-through curves for JCK-_R and JCK-A-_R (2R-24R @25°C)

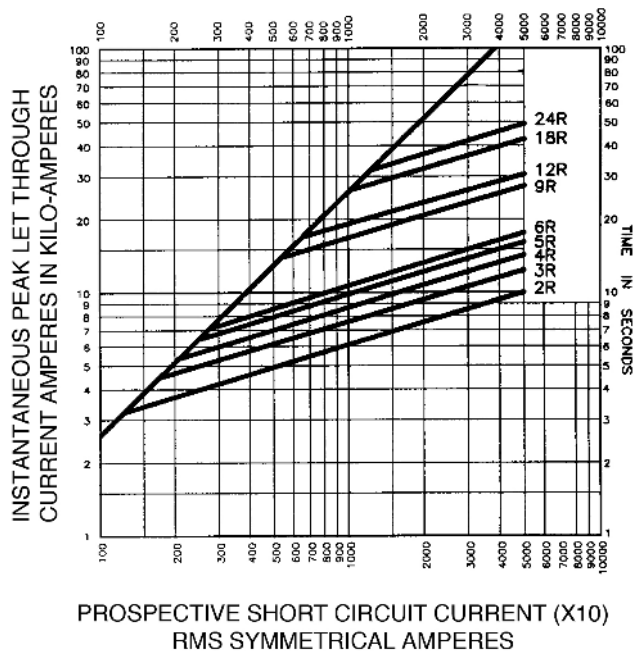

4.8 kV R-Rated fuses

Catalog symbols:

Code-(amps)R	Construction
5CLS-30 and 5CLS-_R	Standard - short (30 A, 2R-24R)
JCL-_R	Standard - short (2R - 24R)
5LCLS-_R	Standard - long (2R - 24R)
5ACLS-30 and 5ACLS-_R	AMPGARD Hookeye* (30 A, 2R-24R)
JCL-A-_R	AMPGARD Hookeye* (2R - 24R)
5HCLS-30 and 5HCLS-_R	Hermetically sealed AMPGARD Hookeye* (30 A, 2R-24R)
5BCLS-30 and 5BCLS-_R	Bolt-on (30 A, 2R-44R)
JCL-B-_R	Bolt-on (2R-24R)
5MCLS-_R-A and 5MCLS-_R-B	Bolt-on GE Limitamp (2R- 24R)

* For use in 400 amp AMPGARD motor starters.

Ratings:

- Volts
 - 4.8 kV (nominal)
 - 5.0 kV (max design)
- Amps 30-800 A
- Interrupting ratings
 - 50 kA Sym
 - 80 kA Asym

Agency information:

- UL Recognized, Guide MSSS2
 - File E96676: JCL-_R [2R-12R], JCL-A-_R [2R-12R], 5MCLS-_R-A [2R-24R], and 5MCLS-_R-B [2R-24R]
 - File E60757: 5CLS-30, 5CLS-_R [2R-18R], 5ACLS-30, and 5ACLS-_R [2R-24R]

Recommended fuse holders for standard constructions

Amp range	Description	BIL (kV)	Cat. No.
Fuseclips			
30-230A	3" Enclosed fuseclip*		A3354730
30-450A	3" Open fuseclip	—	1A0065
	3" Spring loaded open fuseclip		9078A67G04
Fuse holders for CLS / JCL / 5HCLS			
30-230A Single barrel	Non-disconnect holder, porcelain		5HLE-PNM-D
	Non-disconnect holder, glass polyester		5HLE-GNM-D
	Disconnect holder, porcelain	60	5HLE-PDM-D
	Disconnect holder, glass polyester		5HLE-GDM-D
390-450A Double barrel	Non-disconnect holder, porcelain		5HLE-PNM-E
	Non-disconnect holder, glass polyester		5HLE-GNM-E
	Disconnect holder, porcelain		5HLE-PDM-E
Fuse holders for 5LCLS†			
70-230A Single barrel	Non-disconnect holder, porcelain		5CLE-PNM-D
	Non-disconnect holder, glass polyester		5CLE-GNM-D
	Disconnect holder, porcelain	60	5CLE-PDM-D
	Disconnect holder, glass polyester		5CLE-GDM-D
390-450A Double Barrel	Disconnect holder, porcelain	75	8CLE-PDM-D
	Disconnect holder, glass polyester		8CLE-GDM-D
	Disconnect holder, porcelain	60	5CLE-PDM-E
Disconnect holder, glass polyester	5CLE-GDM-E		

* Single barrel only, not sold in pairs.

**Not available for standard - long constructions

† Not available for 390 to 450 amp ratings.

Dimensions - in [mm]

Construction	Amp range	Dimension			
		A	B	C	D
Standard - short	30-230A	15.6 (396)			—
	390-450A				3.3 (84)
Standard - long	70-230A	17.9 (455)	3 (76)	3 (76)	—
	390-450A				3.3 (84)
AMPGARD Hookeye*	30-230A	15.9 (404)			—
	390-450A				3.3 (84)
Bolt-on	30-230A	19.2 (488)	17.9 (455)	3 (76)	—
	390-450A				3.3 (84)
	600-800A				4 (101)
Limitamp (-A)	70-230	18.3 (465)	18.8 (478)	1.4 (36)	4.8 (122)
	390-450				7.4 (188)
Limitamp (-B)	70-230	18.3 (465)	18.8 (478)	1.4 (36)	3.0 (76)
	390-450				2.4 (61)

* Includes hermetically sealed versions.

Ferrule JCL, 5LCLS, 5CLS and AMPGARD Hookeye

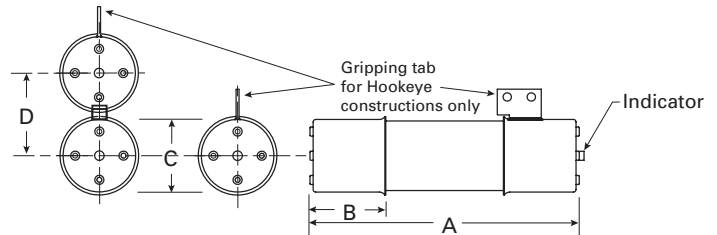

Bolt-on — 5BCLS_

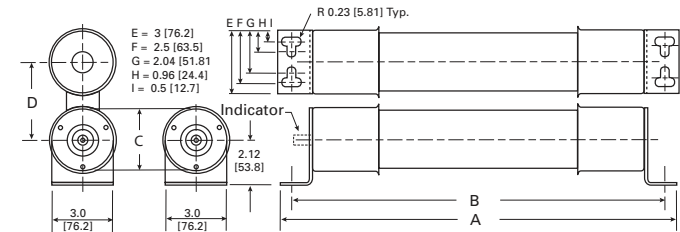

Bolt-on — 5MCLS-_R-A

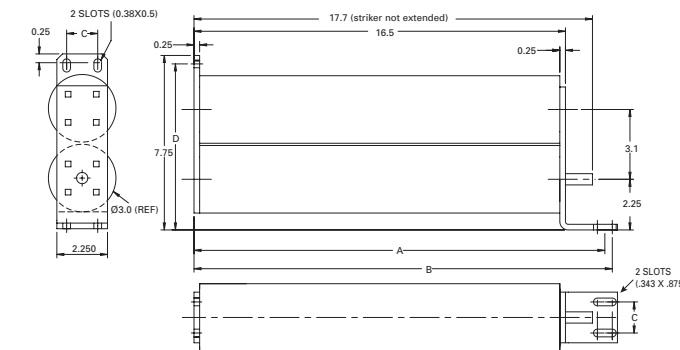

Bolt-on — 5MCLS-_R-B

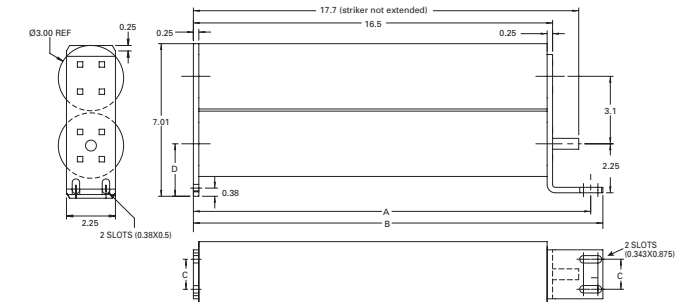

4.8 kV R-Rated fuse catalog numbers

Ferrule constructions (min. interrupting rating in amps)					
Amps	Short	Short	Long	No. of barrels	
30	5CLS-30* (100)	—	—	1	
70	5CLS-2R (180)	JCL-2R (165)	5LCLS-2R (180)†		
100	5CLS-3R (270)	JCL-3R (220)	5LCLS-3R (270)†		
130	5CLS-4R (360)	JCL-4R (320)	5LCLS-4R (360)†		
150	5CLS-5R (450)	JCL-5R (410)	5LCLS-5R (450)†		
170	5CLS-6R (540)	JCL-6R (480)	5LCLS-6R (540)†		
200	5CLS-9R (740)	JCL-9R (720)	5LCLS-9R (740)†		
230	5CLS-12R (1080)	JCL-12R (970)	5LCLS-12R (1080)†		
390	5CLS-18R (1500)	JCL-18R (1430)†	5LCLS-18R (1500)†		2
450	5CLS-24R (2200)†	JCL-24R (1880)†	5LCLS-24R (2200)†		

* Does not comply with ANSI C37.46 for "R" rating.

† Not UL Recognized.

AMPGARD Hookeye (min. interrupting rating in amps)					
Amps	Hookeye	Hookeye	Hermetic seal	No. of barrels	
30	5ACLS-30* (100)	—	5HCLS-30* (100)†	1	
70	5ACLS-2R (180)	JCL-A-2R (165)	5HCLS-2R (180)†		
100	5ACLS-3R (270)	JCL-A-3R (220)	5HCLS-3R (270)†		
130	5ACLS-4R (360)	JCL-A-4R (320)	5HCLS-4R (360)†		
150	5ACLS-5R (450)	JCL-A-5R (410)	5HCLS-5R (450)†		
170	5ACLS-6R (540)	JCL-A-6R (480)	5HCLS-6R (540)†		
200	5ACLS-9R (740)	JCL-A-9R (720)	5HCLS-9R (740)†		
230	5ACLS-12R (1080)	JCL-A-12R (970)	5HCLS-12R (1080)†		
390	5ACLS-18R (1500)	JCL-A-18R (1430)†	5HCLS-18R (1500)†		2
450	5ACLS-24R (2200)	JCL-A-24R (1880)†	5HCLS-24R (2200)†		

* Does not comply with ANSI C37.46 for "R" rating.

† Not UL Recognized.

Bolt-on (min. interrupting rating in amps)					
Amps	Regular	Regular		No. of barrels	
30	5BCLS-30* (100)†	—		1	
70	5BCLS-2R (180)†	JCL-B-2R (165)†			
100	5BCLS-3R (270)†	JCL-B-3R (220)†			
130	5BCLS-4R (360)†	JCL-B-4R (320)†			
150	5BCLS-5R (450)†	JCL-B-5R (410)†			
170	5BCLS-6R (540)†	JCL-B-6R (480)†			
200	5BCLS-9R (740)†	JCL-B-9R (720)†			
230	5BCLS-12R (1080)†	JCL-B-12R (970)†			
390	5BCLS-18R (1500)†	JCL-B-18R (1430)†			2
450	5BCLS-24R (2200)†	JCL-B-24R (1880)†			
600	5BCLS-32R (3000)†	—			
650	5BCLS-36R (3200)†	—			
800	5BCLS-44R (3600)†	—			

* Does not comply with ANSI C37.46 for "R" rating.

† Not UL Recognized.

GE Limitamp (min. interrupting rating in amps)					
Amps	Bolt-on	Bolt-on		No. of barrels	
30	—	—		1	
70	5MCLS-2R-A (180)	5MCLS-2R-B (180)			
100	5MCLS-3R-A (270)	5MCLS-3R-B (270)			
130	5MCLS-4R-A (360)	5MCLS-4R-B (360)			
150	5MCLS-5R-A (450)	5MCLS-5R-B (450)			
170	5MCLS-6R-A (540)	5MCLS-6R-B (540)			
200	5MCLS-9R-A (850)	5MCLS-9R-B (850)			
230	5MCLS-12R-A (1150)	5MCLS-12R-B (1150)			
390	5MCLS-18R-A (1725)	5MCLS-18R-B (1725)			2
450	5MCLS-24R-A (2350)	5MCLS-24R-B (2350)			

* Does not comply with ANSI C37.46 for "R" rating.

† Not UL Recognized.

5CLS, JCL, JCL-A, 5ACLS and 5HCLS Type mountings — in (mm)

Catalog number	Hole centers		Overall length C	Hole Inset D	Hole centers E	Contact height F	Overall height G	BIL rating (kV)
	A	B						
Disconnect single barrel†								
5CLE-GDM-D	15.24 (387.1)		25 (647.7)					
5CLE-PDM-D		6 (152.4)		0.62 (15.7)	1.75 (44.4)	4.5 (114.3)	11.72 (297.7)	60
5HLE-PDM-D	16.25 (412.8)		23 (584.2)					
5HLE-GDM-D								
Disconnect double barrel†								
5CLE-GDM-E	15.24 (387.1)		25 (647.7)					
5CLE-PDM-E		6 (152.4)		0.62 (15.7)	1.75 (44.4)	4.5 (114.3)	15.28 (388.1)	60
5HLE-GDM-E	16.25 (412.8)		23 (584.2)					
5HLE-PDM-E								
Non-disconnect single barrel								
5CLE-GNM-D	15.24 (387.1)		25 (635.0)					
5CLE-PNM-D		6 (152.4)		0.62 (15.7)	1.75 (44.4)	4.5 (114.3)	8.79 (223.3)	60
5HLE-GNM-D	16.25 (412.7)		23 (584.2)					
5HLE-PNM-D								
Non-disconnect double barrel								
5HLE-PNM-E	16.25 (412.7)	6 (152.4)	25 (635.0)	0.62 (15.7)	1.75 (44.4)	4.5 (114.3)	12.48 (317.0)	60
5HLE-GNM-E								

4.8 kV disconnect mounting†

4.8 kV non-disconnect mounting

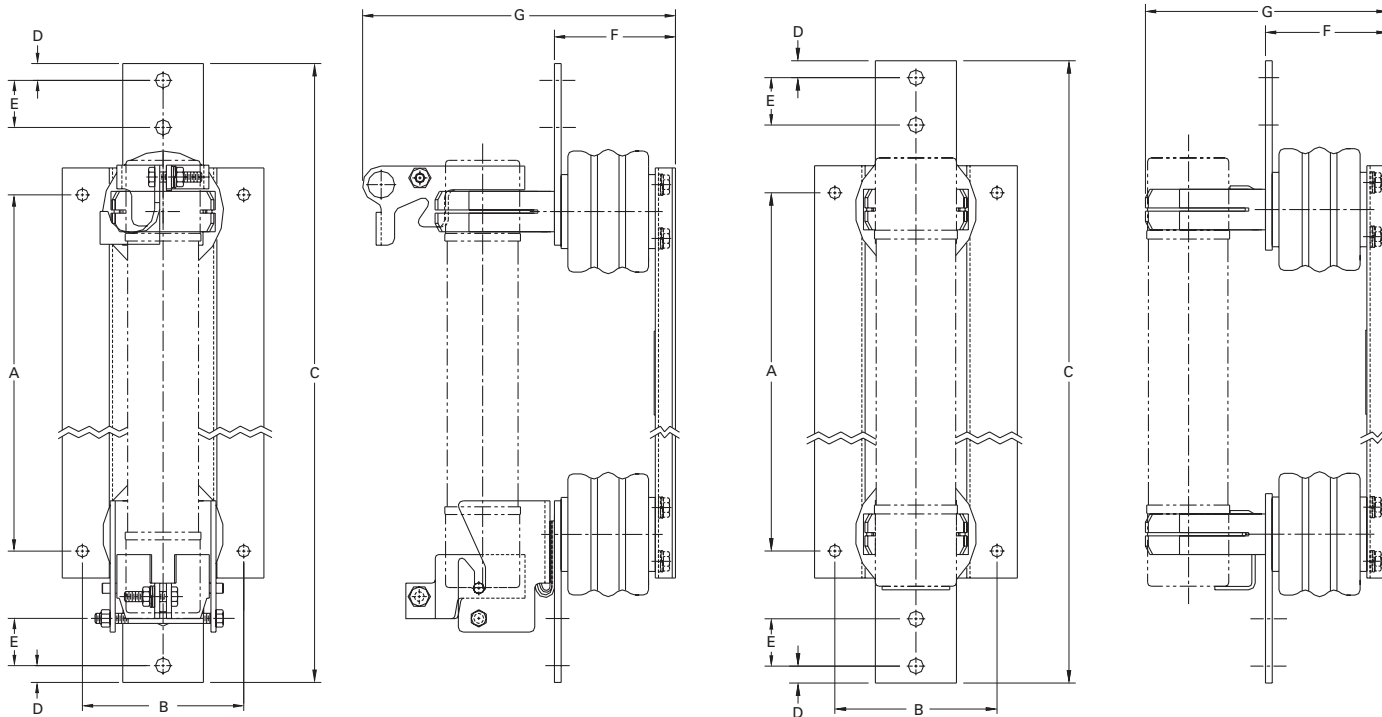

† Disconnect mountings provide a means for fuse extraction only. Do not use a disconnect mounting for load switching or fuse removal while energized.

4.8 kV Time-current curves — minimum melting for 5ACLS-30, 5CLS-30, 5HCLS_R, 5BCLS-30, 5BCLS_R, 5MCLS_R-A and 5MCLS_R-B (30A, 2R-24R @ 25°C)

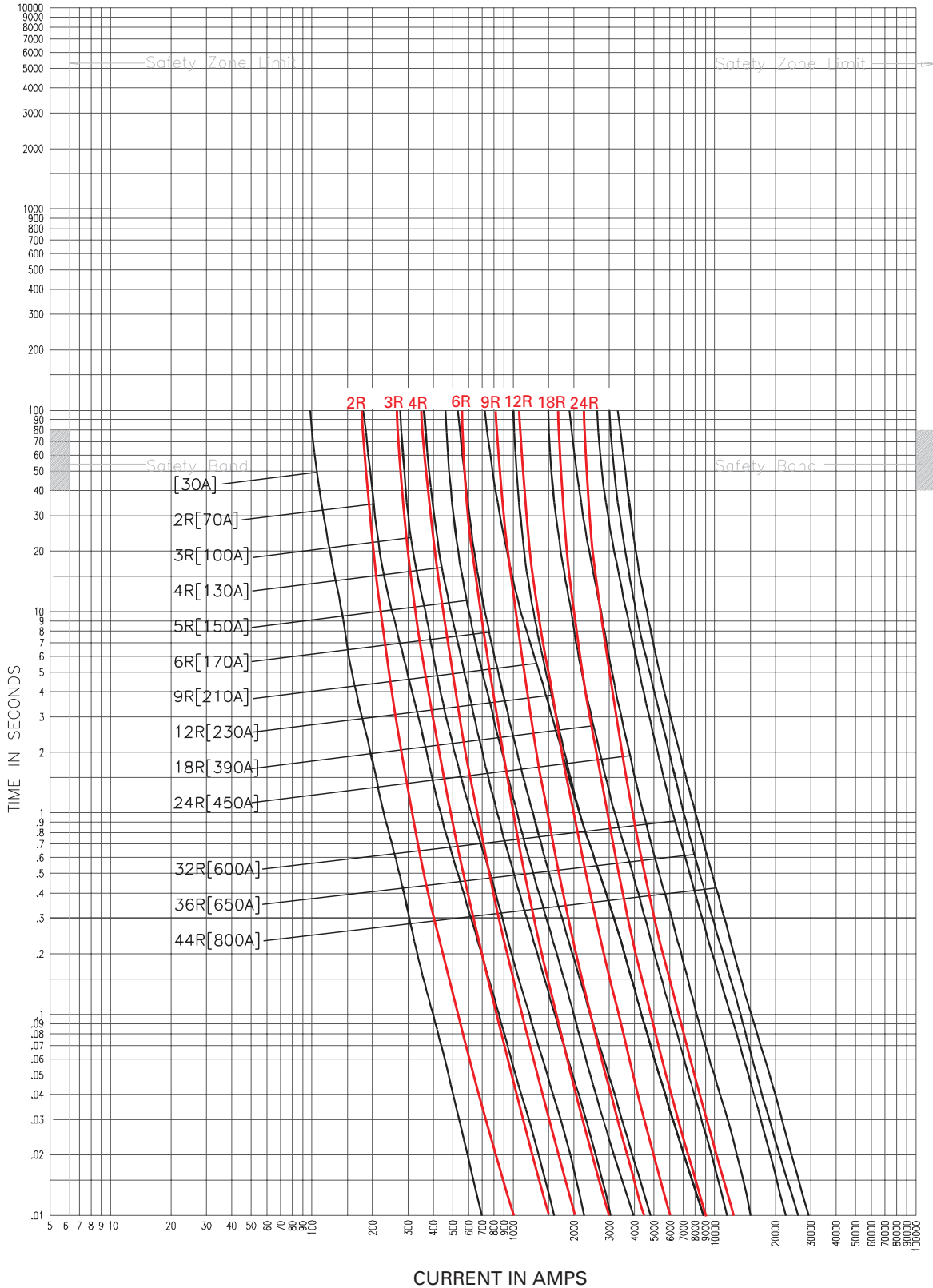

**5ACLS-30, 5CLS-30, 5HCLS_R, 5BCLS-30, 5BCLS_R,
5MCLS_R-A, 5MCLS_R-B**

CURVE 66690602
January 2001
Reference # 666907,
666703, 666910,
667000, 639472.

4.8 kV Time-current curves — total clearing for 5ACLS-30, 5CLS-30, 5HCLS-R, 5BCLS-30, 5BCLS-R, 5MCLS-R-A and 5MCLS-R-B (30A, 2R-24R @ 25°C)

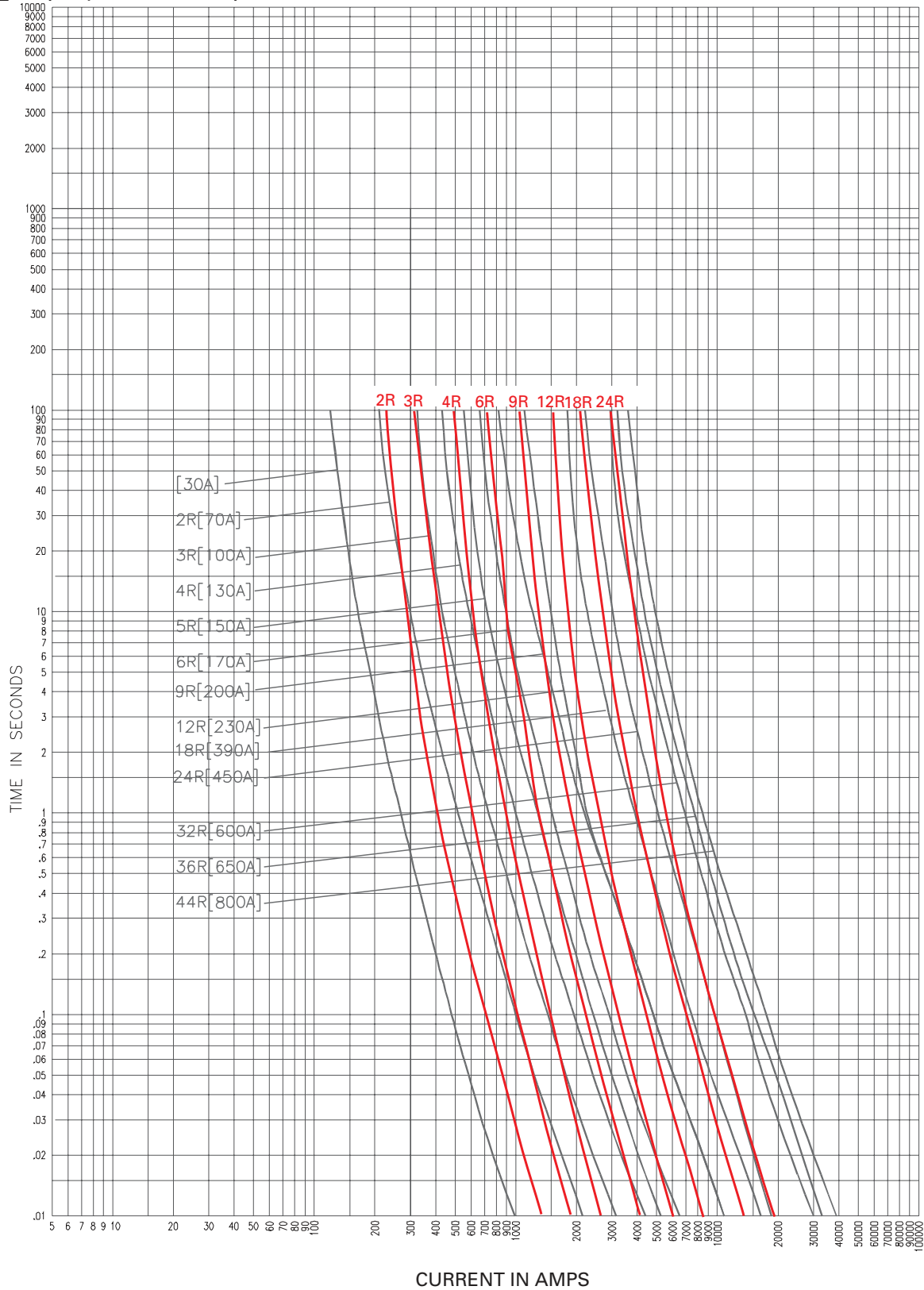

CURVE 66690702
January 2001
Reference # 666907
666704, 666910,
6670001, 639472.

5ACLS-30, 5CLS-30, 5HCLS-R, 5BCLS-30, 5BCLS-R,
5MCLS-R-A, 5MCLS-R-B

4.8 kV Peak let-through curves for 5ACLS-30, 5CLS-30, 5HCLS-R, 5BCLS-30, 5BCLS-R, 5MCLS-R-A and 5MCLS-R-B (30A, 2R-24R @ 25°C)

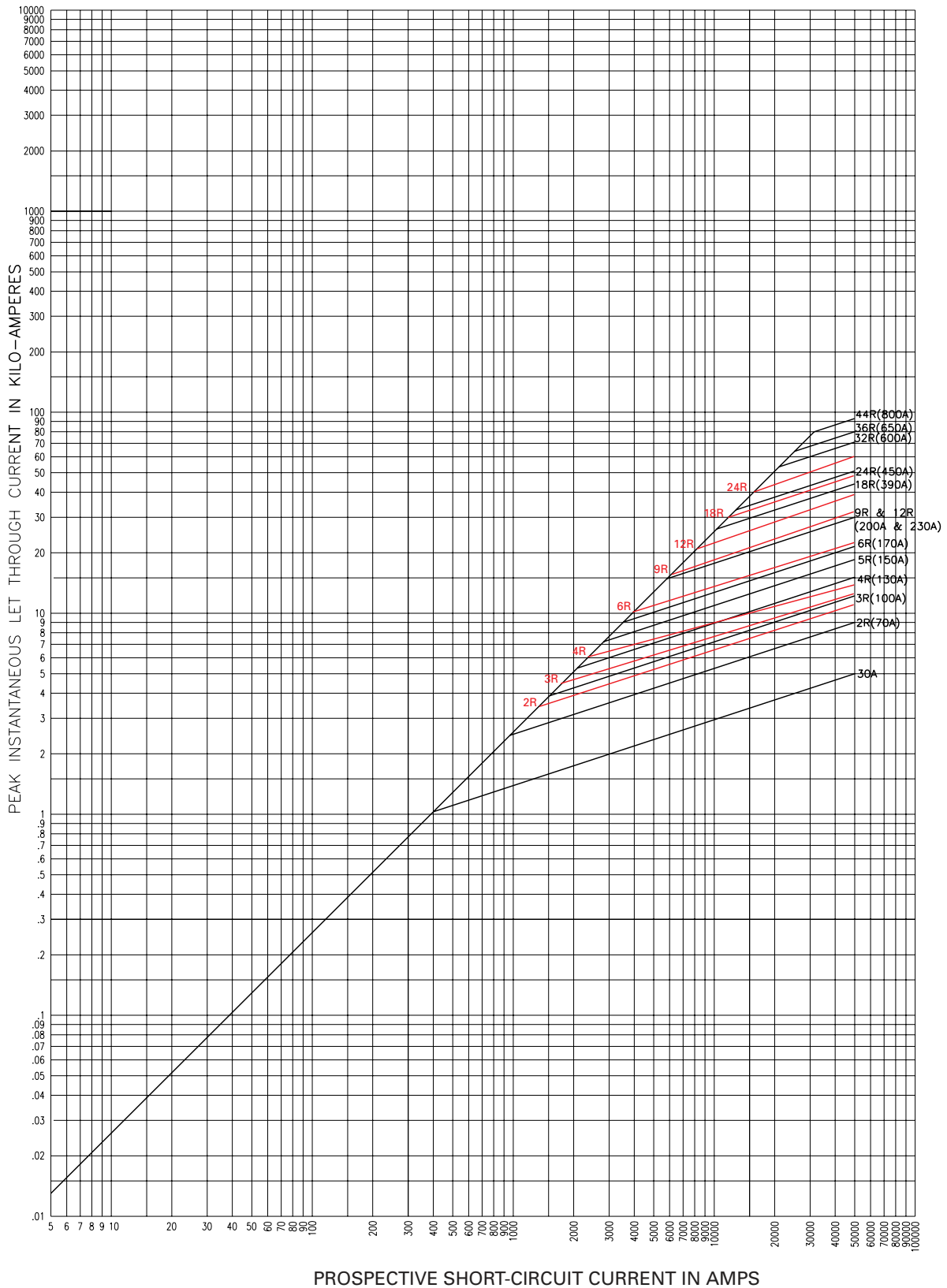

5ACLS-30, 5CLS-30, 5HCLS-R, 5BCLS-30, 5BCLS-R,
5MCLS-R-A, 5MCLS-R-B

CURVE 66700203
January 2001
Reference # 639315
667002, 667008

4.8 kV Time-current curves — minimum melting for JCL_R and JCL-A_R (2R-24R @25°C)

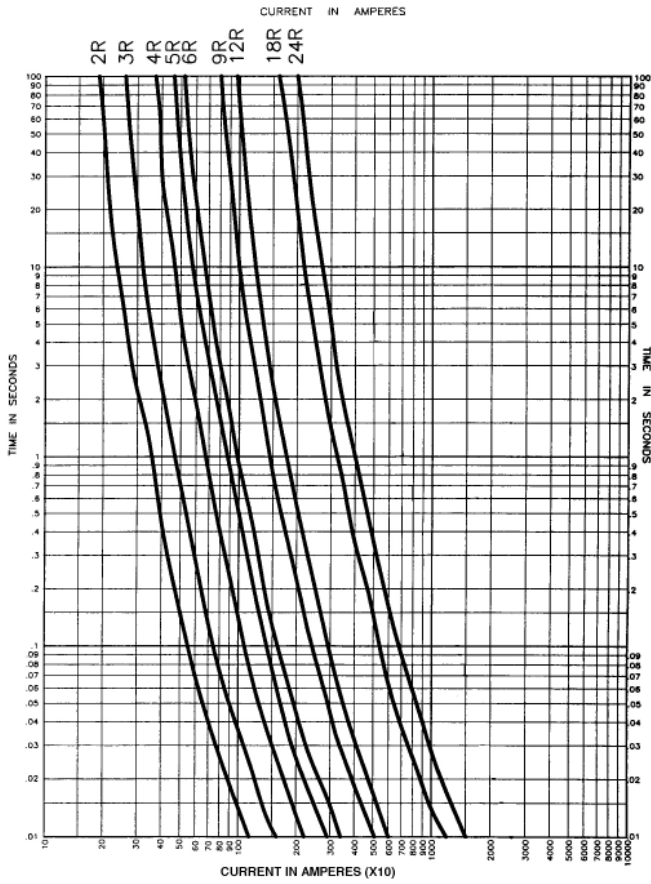

4.8 kV Time-current curves — total clearing for JCL_R and JCL-A_R (2R-24R @25°C)

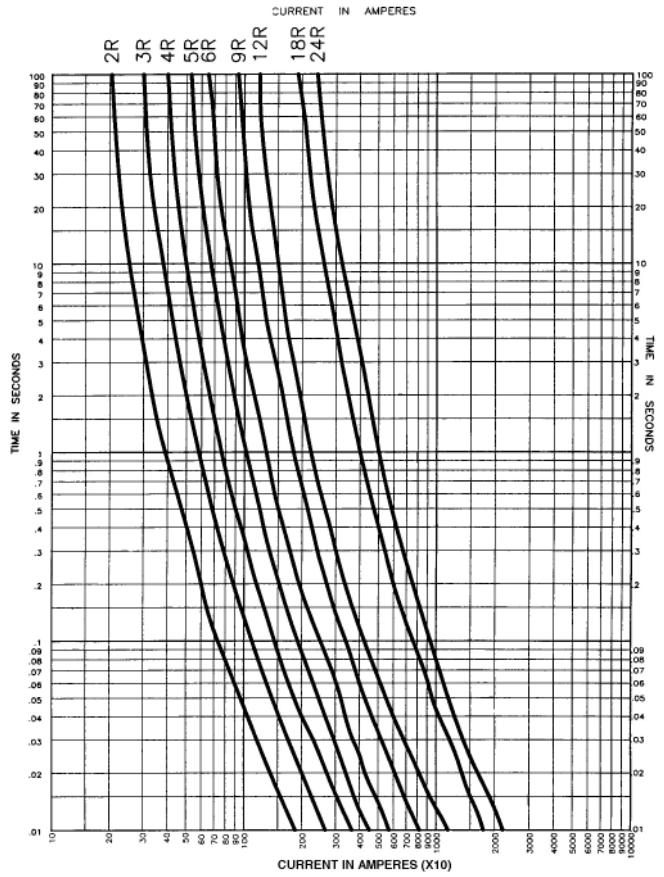

4.8 kV Peak let-through curves for JCL_R and JCL-A_R (2R-24R @25°C)

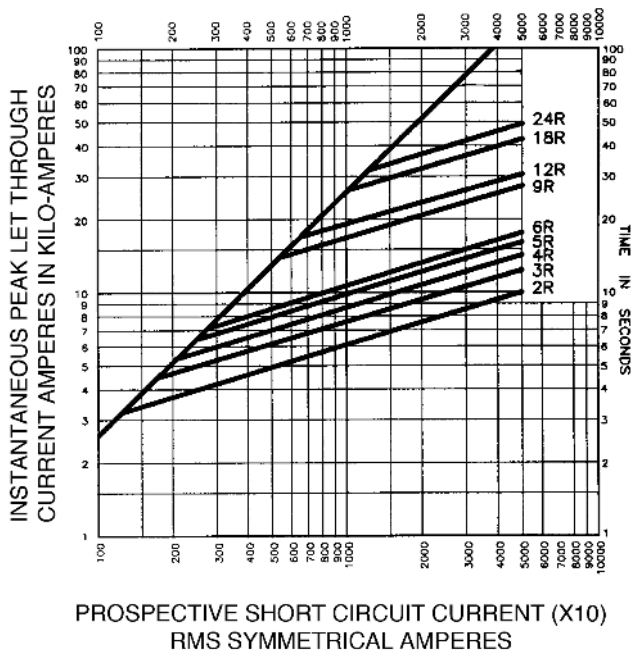

4.8 kV Time-current curves — minimum melting for 5LCLS_R (2R-24R @ 25°C)

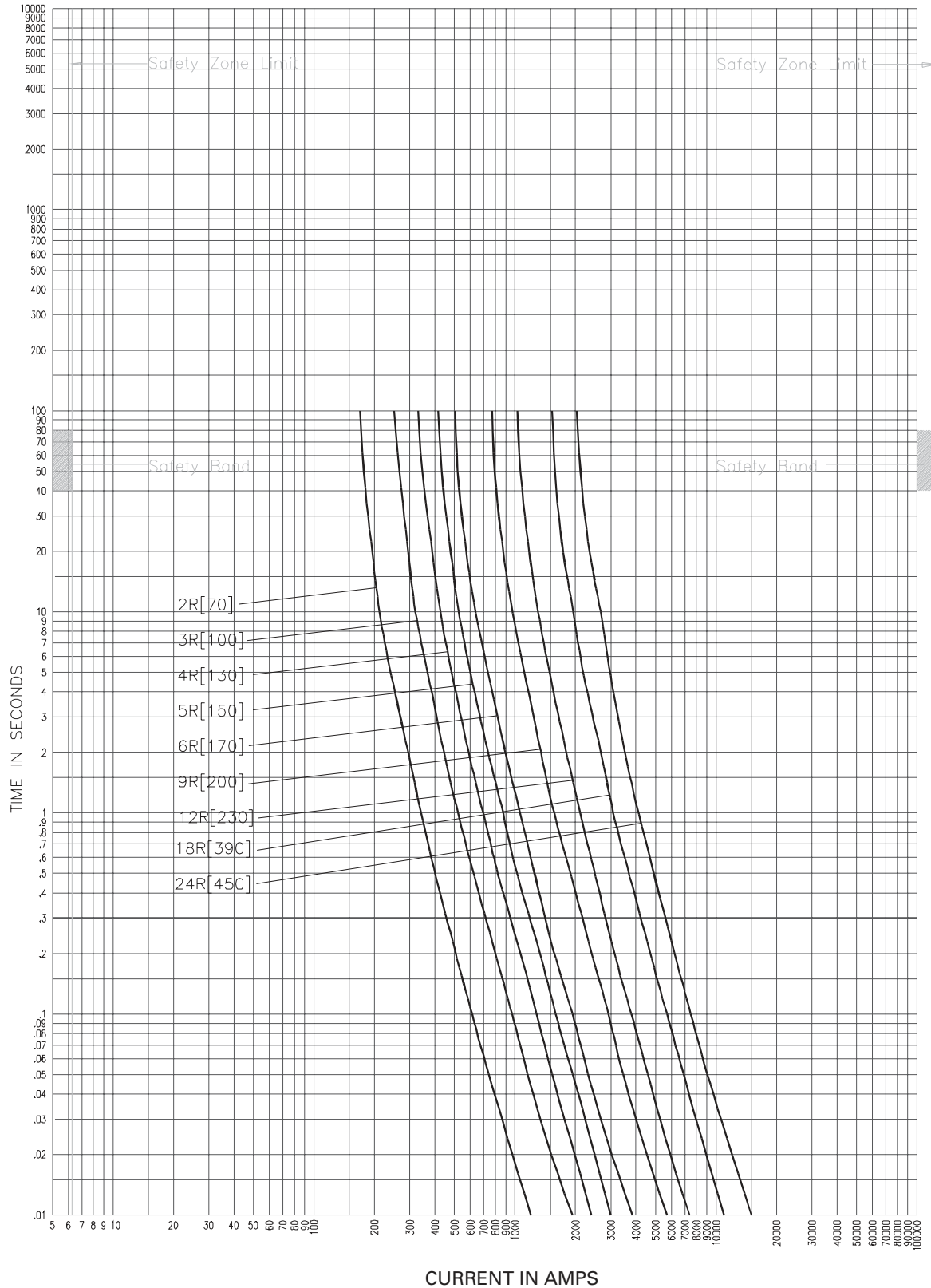

5LCLS_R

CURVE 51285302
January 2001
Reference # 512853,
563863.

4.8 kV Time-current curves — total clearing for 5LCLS-R (2R-24R @ 25°C)

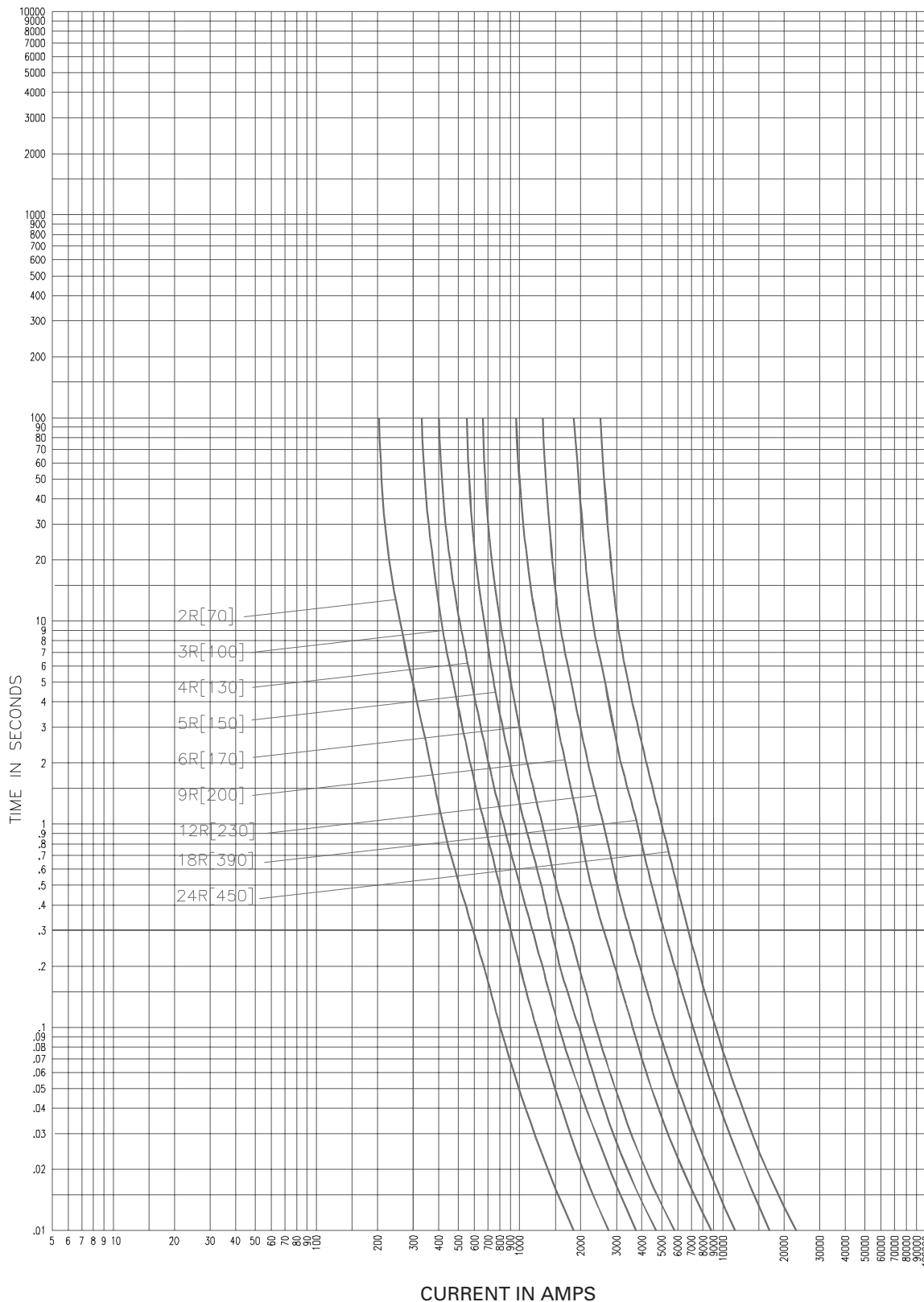

5LCLS-R

CURVE 51285402
 January 2001
 Reference # 512854,
 563864.

4.8 kV Peak let-through curves for 5LCLS_R (2R-24R @ 25°C)

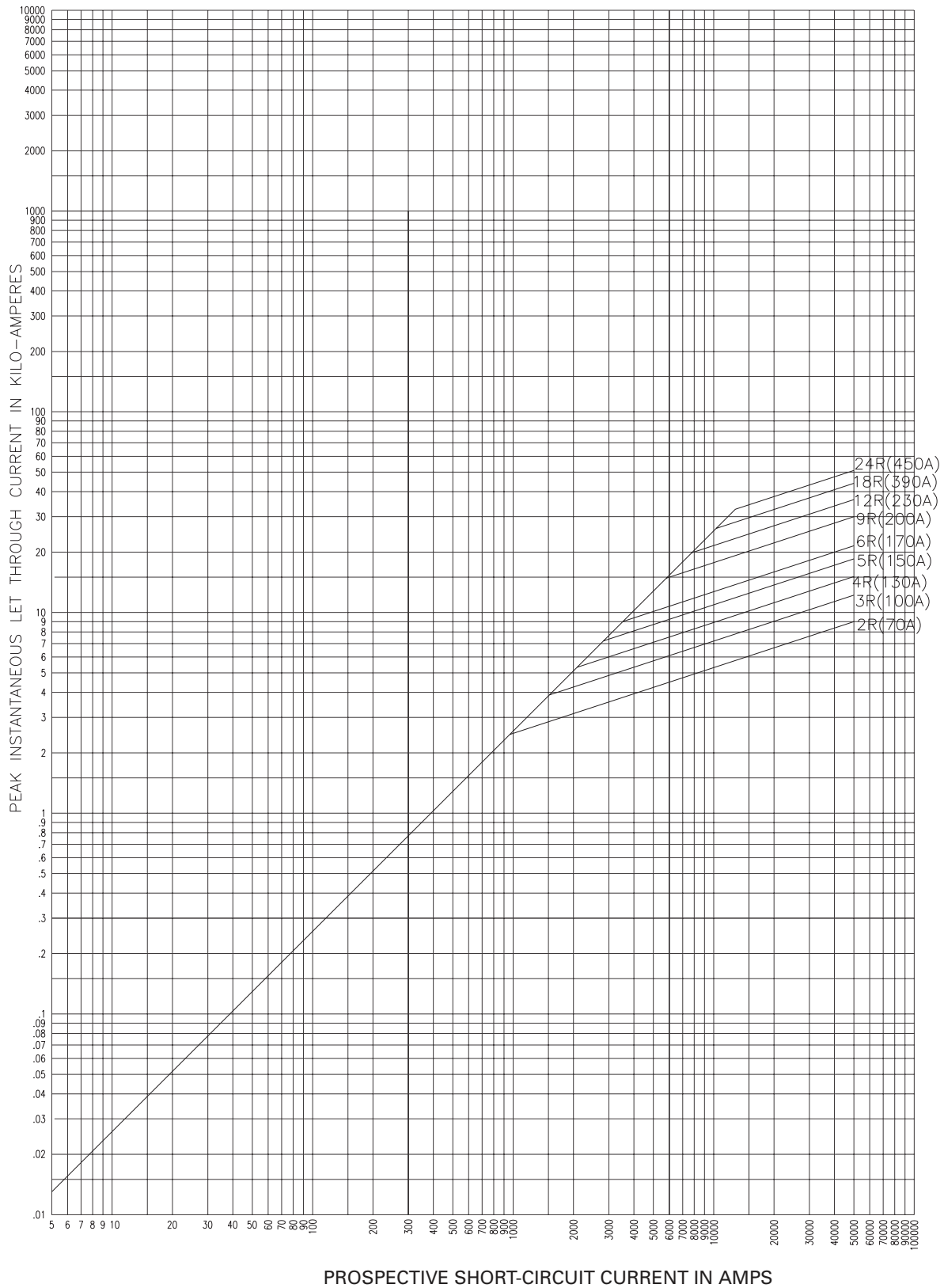

5LCLS_R

CURVE 66700204
January 2001
Reference # 639315

7.2 kV R-Rated fuses

Catalog symbols:

Code-(amps)R	Construction
8CLS_R	Standard (2R - 6R)
8ACLS_R	AMPGARD Hookeye* (2R - 6R)
7BCLS_R	Bolt-on (2R - 6R)

* For use in 400 amp AMPGARD motor starters.

Ratings:

- Volts
 - 7.2 kV (nominal)
 - 8.3 kV (max design 70-170A standard and AMPGARD Hookeye)
 - 7.2 kV (max design 70-170A bolt-on)
- Amps 70-170 A
- Interrupting ratings
 - 50 kA Sym
 - 80 kA Asym

Recommended fuse holders for standard constructions:

Amp range	Description	BIL (kV)	Cat. No.
Fuseclips			
70-170	3" Enclosed fuseclip*	—	A3354730
	3" Open fuseclip		1A0065
	3" Spring loaded open fuseclip		9078A67G04
Fuse holders for 7CLS and 8CLS			
70-170	Non-disconnect holder, porcelain	75	8HLE-PNM-D
	Non-disconnect holder, glass polyester		8HLE-GNM-D
	Disconnect holder, porcelain		8HLE-PDM-D
	Disconnect holder, glass polyester		8HLE-GDM-D

* Single barrel only, not sold in pairs.

7.2 kV R-Rated fuse catalog numbers

Amp rating	"R" Designation	Mounting style (minimum interrupting rating in amps)			Number of barrels
		Standard	AMPGARD Hookeye	Bolt-on	
70	2R	8CLS-2R (160)	8ACLS-2R (160)	7BCLS-2R (160)	1
100	3R	8CLS-3R (250)	8ACLS-3R (250)	7BCLS-3R (250)	
130	4R	8CLS-4R (325)	8ACLS-4R (325)	7BCLS-4R (325)	
150	5R	8CLS-5R (390)	8ACLS-5R (390)	7BCLS-5R (390)	
170	6R	8CLS-6R (500)	8ACLS-6R (500)	7BCLS-6R (500)	

8CLS, 8ACLS, 7CLS, 7ACLS Type mountings — in (mm)

Catalog number	Hole centers		Overall length C	Hole inset D	Hole centers E	Contact height F	Overall height G	BIL (kV)
	A	B						
Disconnect single barrel†								
8HLE-GDM-D	16.25 (412.8)	6 (152.4)	23 (584.2)	0.62 (15.7)	1.75 (44.4)	7 (177.8)	11.72 (297.7)	75
8HLE-PDM-D								
Non-disconnect single barrel								
8HLE-GNM-D	16.25 (412.7)	6 (152.4)	23 (584.2)	0.62 (15.7)	1.75 (44.4)	7 (177.8)	11.29 (286.7)	75
8HLE-PNM-D								

Dimensions — in [mm]

Construction	Amp range	Dimension		
		A	B	C
Standard	70-170	15.8 (401)	3 (76)	3 (76)
AMPGARD Hookeye		19.2 (488)	17.9 (455)	3 (76)
Bolt-on				

Standard and AMPGARD Hookeye

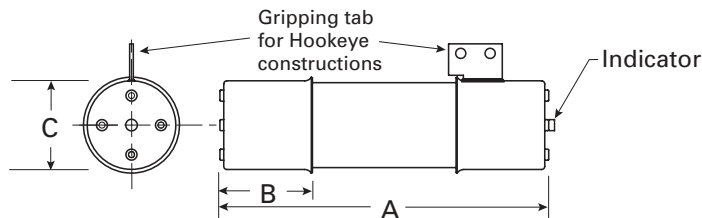

Bolt-on

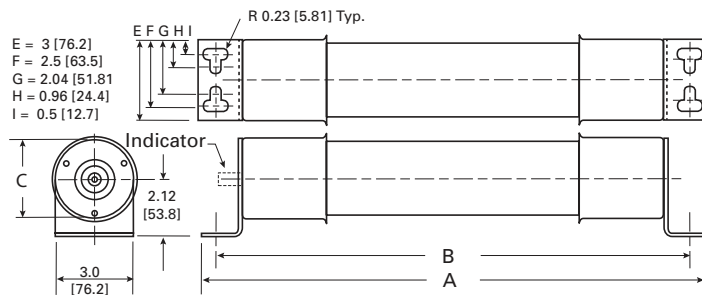

8CLS, 8ACLS, 7BCLS Type mountings — in (mm)

Catalog number	Hole centers		Overall length C	Hole inset D	Hole centers E	Contact height F	Overall height G	BIL (kV)
	A	B						
Disconnect†								
8HLE-GDM-D	16.25 (412.8)	6 (152.4)	23 (584.2)	0.62 (15.7)	1.75 (44.4)	7 (177.8)	11.72 (297.7)	75
8HLE-PDM-D								
Non-disconnect								
8HLE-GNM-D	16.25 (412.7)	6 (152.4)	23 (584.2)	0.62 (15.7)	1.75 (44.4)	7 (177.8)	11.29 (286.7)	75
8HLE-PNM-D								

7.2 kV disconnect mounting†

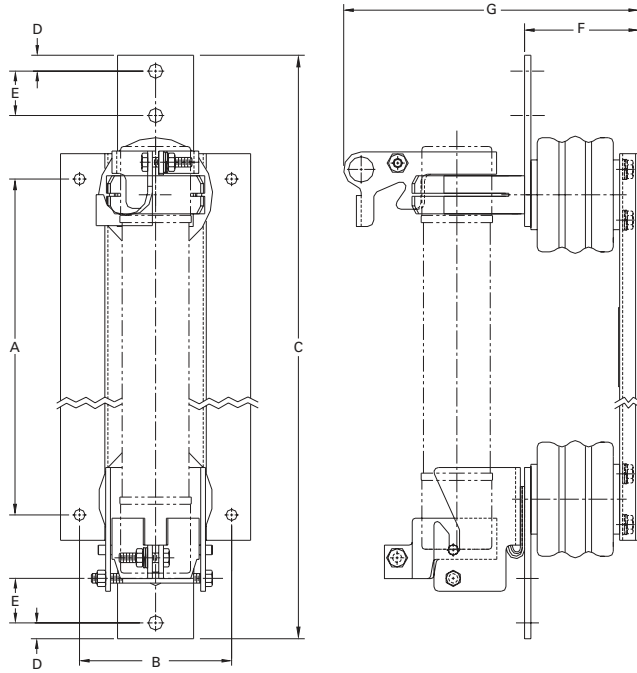

7.2 kV non-disconnect mounting

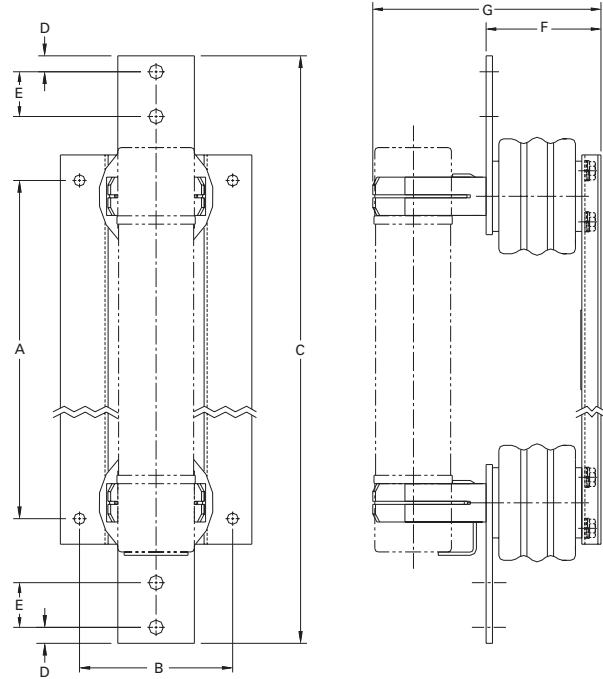

† Disconnect mountings provide a means for fuse extraction only. Do not use a disconnect mounting for load switching or fuse removal while energized.

7.2 kV Time-current curves — minimum melting for 8CLS- R, 7CLS- R, 8ACLS- R, 7ACLS- R and 7BCLS- R (2R-44R @ 25C)

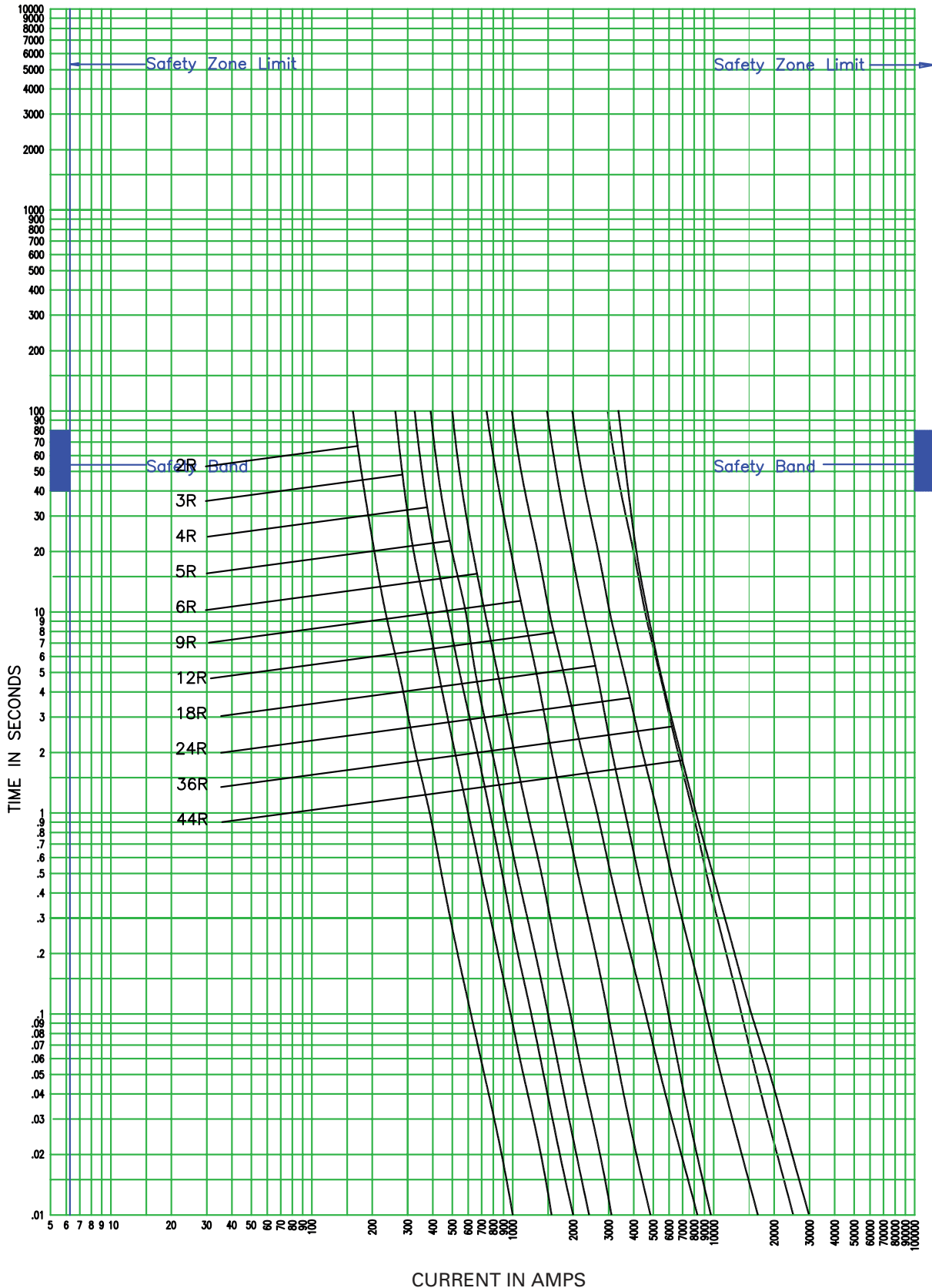

CURVE TC66700602
 December 2008

8CLS- R, 7CLS- R, 8ACLS- R, 7ACLS- R and 7BCLS- R

7.2 kV Time-current curves — total clearing for 8CLS-R, 7CLS-R, 8ACLS-R, 7ACLS-R and 7BCLS-R (2R-44R @ 25C)

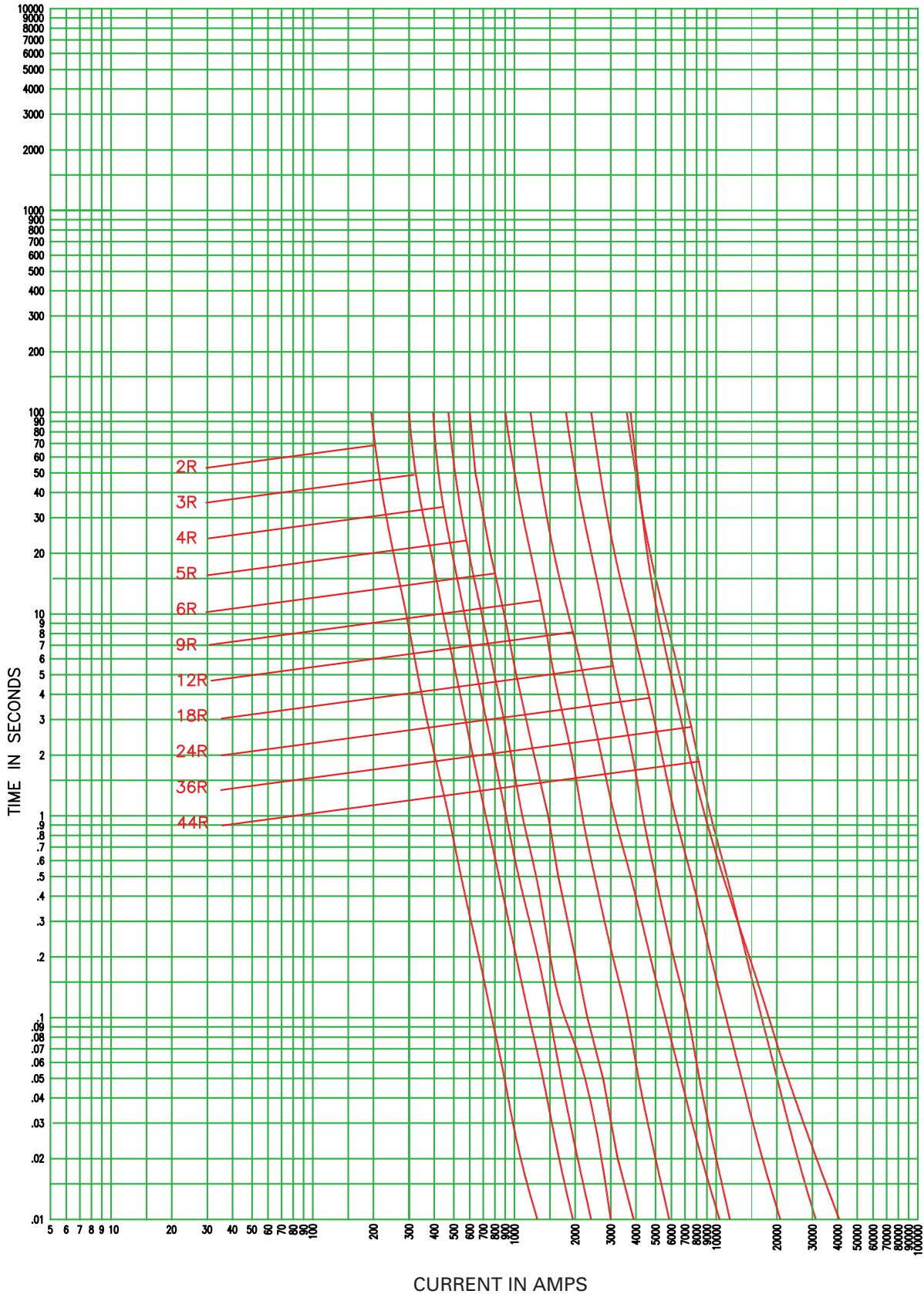

8CLS-R, 7CLS-R, 8ACLS-R, 7ACLS-R and 7BCLS-R

CURVE TC66700702
December 2008

7.2 kV Peak let-through curves for 8CLS-_R, 7CLS-_R, 8ACLS-_R, 7ACLS-_R and 7BCLS-_R (2R-44R @ 25C)

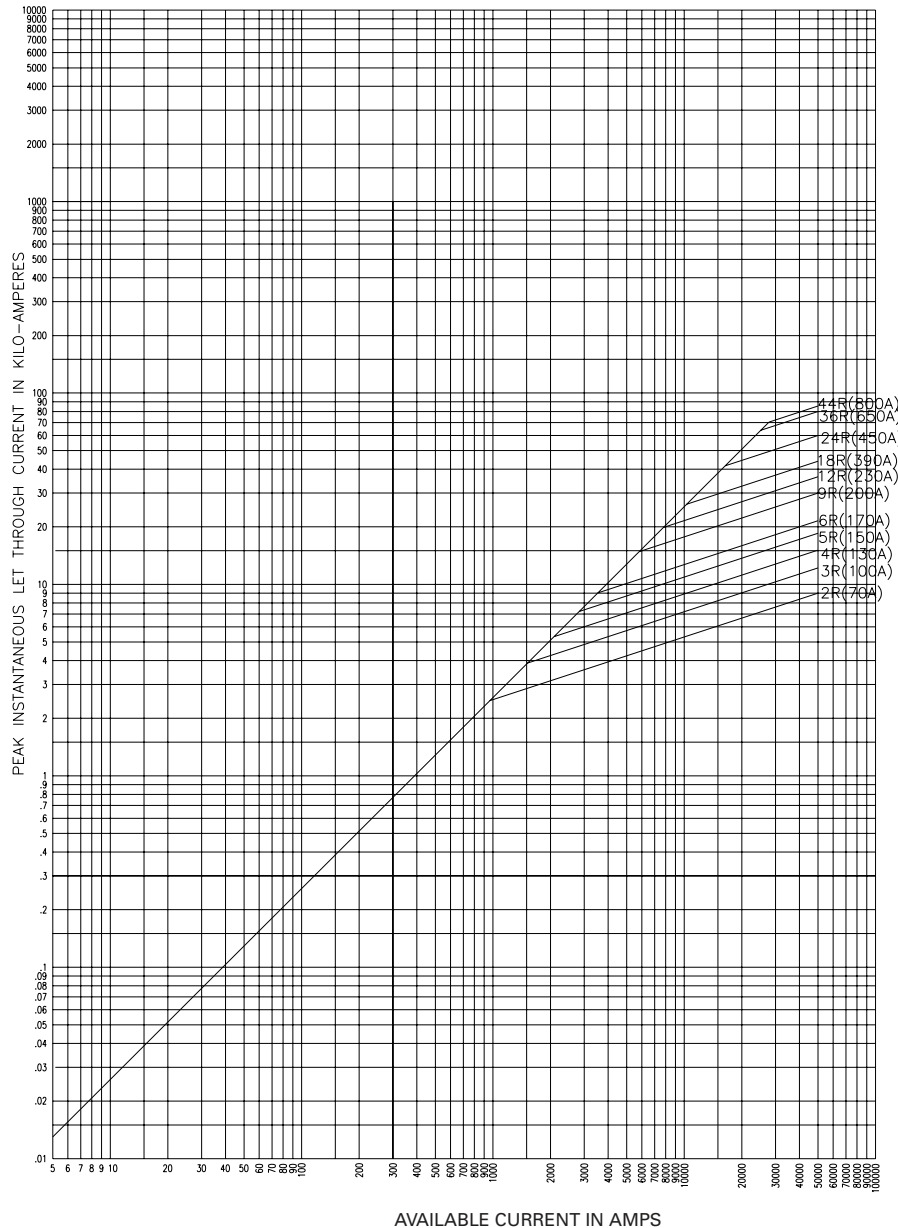

CURVE 66700205
January 2001
Reference # 639315
667002, 667008

8CLS-_R, 7CLS-_R, 8ACLS-_R, 7ACLS-_R and 7BCLS-_R

The only controlled copy of this Data Sheet is the electronic read-only version located on the Bussmann Network Drive. All other copies of this document are by definition uncontrolled. This bulletin is intended to clearly present comprehensive product data and provide technical information that will help the end user with design applications. Bussmann reserves the right, without notice, to change design or construction of any products and to discontinue or limit distribution of any products. Bussmann also reserves the right to change or update, without notice, any technical information contained in this bulletin. Once a product has been selected, it should be tested by the user in all possible applications.

Eaton
1000 Eaton Boulevard
Cleveland, OH 44122
Eaton.com

Bussmann Division
114 Old State Road
Ellisville, MO 63021
United States
Eaton.com/bussmannseries

© 2018 Eaton
All Rights Reserved
Publication No. 6001 - BU-SB15148
October 2018

Eaton, Bussmann and AMPGARD are valuable trademarks of Eaton in the U.S. and other countries. You are not permitted to use the Eaton trademarks without prior written consent of Eaton.

Limitamp is a registered trademark of General Electric.
UL is a registered trademark of Underwriters Laboratories, Inc.

For Eaton's Bussmann series product information, call 1-855-287-7626 or visit: Eaton.com/bussmannseries

Follow us on social media to get the latest product and support information.

