

REVISIONS

P	LTR	DESCRIPTION	DATE	DWN	APVD
	A	INITIAL RELEASE PER ECO-19-010993	7/12/2019	J.B.	T.L.

RAYCHEM RW-175 Tubing SCD

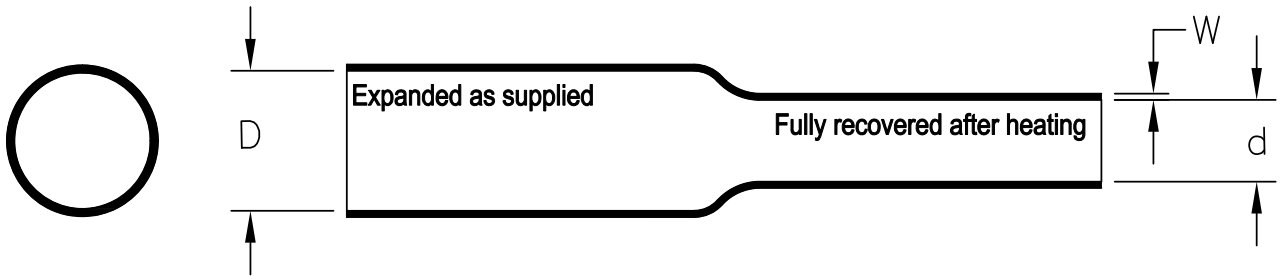



Table 1: Dimensions mm(*inches*)

Size	As Supplied		As Recovered							
	Inside Diameter		Inside Diameter		Wall Thickness					
	Minimum		Maximum		Minimum		Maximum		Nominal	
	mm.	<i>in.</i>	mm.	<i>in.</i>	mm.	<i>in.</i>	mm.	<i>in.</i>	mm.	<i>in.</i>
3/64	1.17	0.046	0.58	0.023	0.20	0.008	0.31	0.012	0.25	0.010
1/16	1.60	0.063	0.79	0.031	0.20	0.008	0.31	0.012	0.25	0.010
3/32	2.36	0.093	1.17	0.046	0.20	0.008	0.31	0.012	0.25	0.010
1/8	3.18	0.125	1.58	0.062	0.20	0.008	0.31	0.012	0.25	0.010
3/16	4.75	0.187	2.36	0.093	0.20	0.008	0.31	0.012	0.25	0.010
1/4	6.35	0.250	3.18	0.125	0.28	0.011	0.38	0.015	0.33	0.013
3/8	9.53	0.375	4.75	0.187	0.28	0.011	0.38	0.015	0.33	0.013
1/2	12.70	0.500	6.35	0.250	0.28	0.011	0.38	0.015	0.33	0.013
3/4	19.05	0.750	9.53	0.375	0.36	0.014	0.51	0.020	0.43	0.017
1	25.40	1.000	12.70	0.500	0.41	0.016	0.56	0.022	0.48	0.019
1-1/2	38.10	1.500	19.05	0.750	0.43	0.017	0.58	0.023	0.51	0.020
2	50.80	2.000	25.40	1.000	0.43	0.017	0.58	0.023	0.51	0.020

Color: Standard Clear (Translucent light tan)
Non-Standard Black

Reference Specification 108-120022

THIS DRAWING IS UNPUBLISHED. ALL RIGHTS RESERVED. © COPYRIGHT 2019 TE Connectivity Ltd.

DIMENSIONS: INCHES	DWN J. Bitter	12-Mar-2019	MATERIAL -	FINISH -
	CHK T. Licko	-	 TE Connectivity Ltd.	
TOLERANCES UNLESS OTHERWISE SPECIFIED: 0 PLC ± - 1 PLC ± - 2 PLC ± - 3 PLC ± - 4 PLC ± - ANGLES ± -	APVD T. Licko	-		
	PRODUCT SPEC 108-120022	-	SIZE A4	CAGE CODE 06090
	APPLICATION SPEC -	-	DRAWING NO C-RW-175	RESTRICTED TO -
	WEIGHT -	-	SCALE 1:1	SHEET 1 OF 1
CUSTOMER DRAWING			REV A	