

Addendum for New QFN Package Migration

This addendum provides the changes to the 98A case outline numbers for products covered in this book. Case outlines were changed because of the migration from gold wire to copper wire in some packages. See the table below for the old (gold wire) package versus the new (copper wire) package.

To view the new drawing, go to Freescale.com and search on the new 98A package number for your device.

For more information about QFN package use, see EB806: *Electrical Connection Recommendations for the Exposed Pad on QFN and DFN Packages*.

Part Number	Package Description	Original (gold wire) package document number	Current (copper wire) package document number
MC68HC908JW32	48 QFN	98ARH99048A	98ASA00466D
MC9S08AC16			
MC9S908AC60			
MC9S08AC128			
MC9S08AW60			
MC9S08GB60A			
MC9S08GT16A			
MC9S08JM16			
MC9S08JM60			
MC9S08LL16			
MC9S08QE128			
MC9S08QE32			
MC9S08RG60			
MCF51CN128			
MC9RS08LA8	48 QFN	98ARL10606D	98ASA00466D
MC9S08GT16A	32 QFN	98ARH99035A	98ASA00473D
MC9S908QE32	32 QFN	98ARE10566D	98ASA00473D
MC9S908QE8	32 QFN	98ASA00071D	98ASA00736D
MC9S08JS16	24 QFN	98ARL10608D	98ASA00734D
MC9S08QB8			
MC9S08QG8	24 QFN	98ARL10605D	98ASA00474D
MC9S08SH8	24 QFN	98ARE10714D	98ASA00474D
MC9RS08KB12	24 QFN	98ASA00087D	98ASA00602D
MC9S08QG8	16 QFN	98ARE10614D	98ASA00671D
MC9RS08KB12	8 DFN	98ARL10557D	98ASA00672D
MC9S08QG8			
MC9RS08KA2	6 DFN	98ARL10602D	98ASA00735D



MC9S08QE32 Series

Covers: MC9S08QE32 and MC9S08QE16

MC9S08QE32

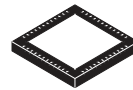

48-QFN
Case 1314
7 mm × 7 mm



44-LQFP
Case 824D
10 mm × 10 mm



32-LQFP
Case 873A
7 mm × 7 mm

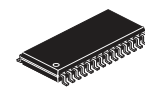

28-SOIC
Case 751F

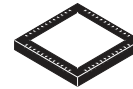

32-QFN
Case 1582
5 mm × 5 mm

Features

- 8-Bit HCS08 Central Processor Unit (CPU)
 - Up to 50.33 MHz HCS08 CPU at 3.6 V to 2.4 V, 40 MHz CPU at 2.4 V to 2.1 V and 20 MHz CPU at 2.1 V to 1.8 V across temperature range of -40 °C to 85 °C
 - HC08 instruction set with added BGND instruction
 - Support for up to 32 interrupt/reset sources
- On-Chip Memory
 - Flash read/program/erase over full operating voltage and temperature
 - Random-access memory (RAM)
 - Security circuitry to prevent unauthorized access to RAM and flash contents
- Power-Saving Modes
 - Two very low power stop modes
 - Reduced power wait mode
 - Peripheral clock enable register can disable clocks to unused modules, thereby reducing currents; allows clocks to remain enabled to specific peripherals in stop3 mode.
 - Very low power external oscillator that can be used in run, wait, and stop modes to provide accurate clock source to real time counter.
 - 6 μs typical wakeup time from stop3 mode
- Clock Source Options
 - Oscillator (XOSCVP) — Loop-control Pierce oscillator; crystal or ceramic resonator range of 31.25 kHz to 38.4 kHz or 1 MHz to 16 MHz
 - Internal clock source (ICS) — Internal clock source module containing a frequency-locked-loop (FLL) controlled by internal or external reference; precision trimming of internal reference allows 0.2% resolution and 2% deviation over temperature and voltage; supports CPU frequencies from 4 kHz to 50.33 MHz.
- System Protection
 - Watchdog computer operating properly (COP) reset with option to run from dedicated 1 kHz internal clock source or bus clock.
 - Low-voltage warning with interrupt.
 - Low-voltage detection with reset or interrupt
 - Selectable trip points.
 - Illegal opcode detection with reset
 - Illegal address detection with reset
 - Flash block protection
- Development Support
 - Single-wire background debug interface
 - Breakpoint capability to allow single breakpoint setting during in-circuit debugging (plus three breakpoints in on-chip debug module)
- On-chip in-circuit emulator (ICE) debug module containing three comparators and nine trigger modes. Eight deep FIFO for storing change-of-flow addresses and event-only data. Debug module supports both tag and force breakpoints
- Peripherals
 - **ADC** — 10-channel, 12-bit resolution; 2.5 μs conversion time; automatic compare function; 1.7 mV/°C temperature sensor; internal bandgap reference channel; operation in stop3; fully functional from 3.6 V to 1.8 V
 - **ACMPx** — Two analog comparators with selectable interrupt on rising, falling, or either edge of comparator output; compare option to fixed internal bandgap reference voltage; outputs can be optionally routed to TPM module; operation in stop3
 - **SCIx** — Two serial communications interface modules with optional 13-bit break. Full duplex non-return to zero (NRZ); LIN master extended break generation; LIN slave extended break detection; wake on active edge.
 - **SPI** — One serial peripheral interface; full-duplex or single-wire bidirectional; double-buffered transmit and receive; master or slave mode; MSB-first or LSB-first shifting
 - **IIC** — One IIC; up to 100 kbps with maximum bus loading; multi-master operation; programmable slave address; interrupt driven byte-by-byte data transfer; supports broadcast mode and 10-bit addressing
 - **TPMx** — One 6-channel (TPM3) and two 3-channel (TPM1 and TPM2); selectable input capture, output compare, or buffered edge- or center-aligned PWM on each channel;
 - **RTC** — (Real-time counter) 8-bit modulus counter with binary or decimal based prescaler; external clock source for precise time base, time-of-day, calendar or task scheduling functions; free running on-chip low power oscillator (1 kHz) for cyclic wake-up without external components; runs in all MCU modes
- Input/Output
 - 40 GPIOs, including 1 output-only pin and 1 input-only pin
 - 16 KBI interrupts with selectable polarity
 - Hysteresis and configurable pull up device on all input pins; Configurable slew rate and drive strength on all output pins.
- Package Options
 - 48-pin QFN, 44-pin LQFP, 32-pin LQFP/QFN, 28-pin SOIC

This document contains information on a product under development. Freescale reserves the right to change or discontinue this product without notice.

Table of Contents

1	MCU Block Diagram	3	3.9	Internal Clock Source (ICS) Characteristics	19
2	Pin Assignments	4	3.10	AC Characteristics	20
3	Electrical Characteristics	9	3.10.1	Control Timing	20
3.1	Introduction	9	3.10.2	TPM Module Timing	21
3.2	Parameter Classification	9	3.10.3	SPI Timing	22
3.3	Absolute Maximum Ratings	9	3.11	Analog Comparator (ACMP) Electricals	26
3.4	Thermal Characteristics	10	3.12	ADC Characteristics	26
3.5	ESD Protection and Latch-Up Immunity	12	3.13	Flash Specifications	29
3.6	DC Characteristics	12	4	Ordering Information	30
3.7	Supply Current Characteristics	16	5	Package Information	30
3.8	External Oscillator (XOSC_VLP) Characteristics	18	5.1	Mechanical Drawings	30

Revision History

To provide the most up-to-date information, the revision of our documents on the World Wide Web will be the most current. Your printed copy may be an earlier revision. To verify you have the latest information available, refer to:

<http://freescale.com/>

The following revision history table summarizes changes contained in this document.

Revision	Date	Description of Changes
1	7/2/2008	Initial public released.
2	10/7/2008	Updated the Stop2 and Stop3 mode supply current, and $R_{I_{DD}}$ in FEI mode with all modules on at 25.165 MHz in the Table 8 Supply Current Characteristics. Replaced the stop mode adders section from Table 8 with an individual Table 9 Stop Mode Adders with new specifications.
3	11/4/2008	Updated operating voltage in Table 7 .
4	5/4/2009	Added 10×10 mm information to 44 LQFP in the front page. In Table 7 , added I_{OZTOT} . In Table 11 , updated typicals and Max. for t_{IRST} . In Table 16 , removed the Rev. Voltage High item. Updated Table 17 .
5	8/27/2009	Updated f_{int_t} and f_{int_ut} in the Table 11 .
6	10/13/2009	Corrected the package size descriptions on the cover
7	9/16/2011	Added new package of 32-pin QFN.

Related Documentation

Find the most current versions of all documents at: <http://www.freescale.com>

Reference Manual (MC9S08QE32RM)

Contains extensive product information including modes of operation, memory, resets and interrupts, register definition, port pins, CPU, and all module information.

1 MCU Block Diagram

The block diagram, Figure 1, shows the structure of the MC9S08QE32 MCU.

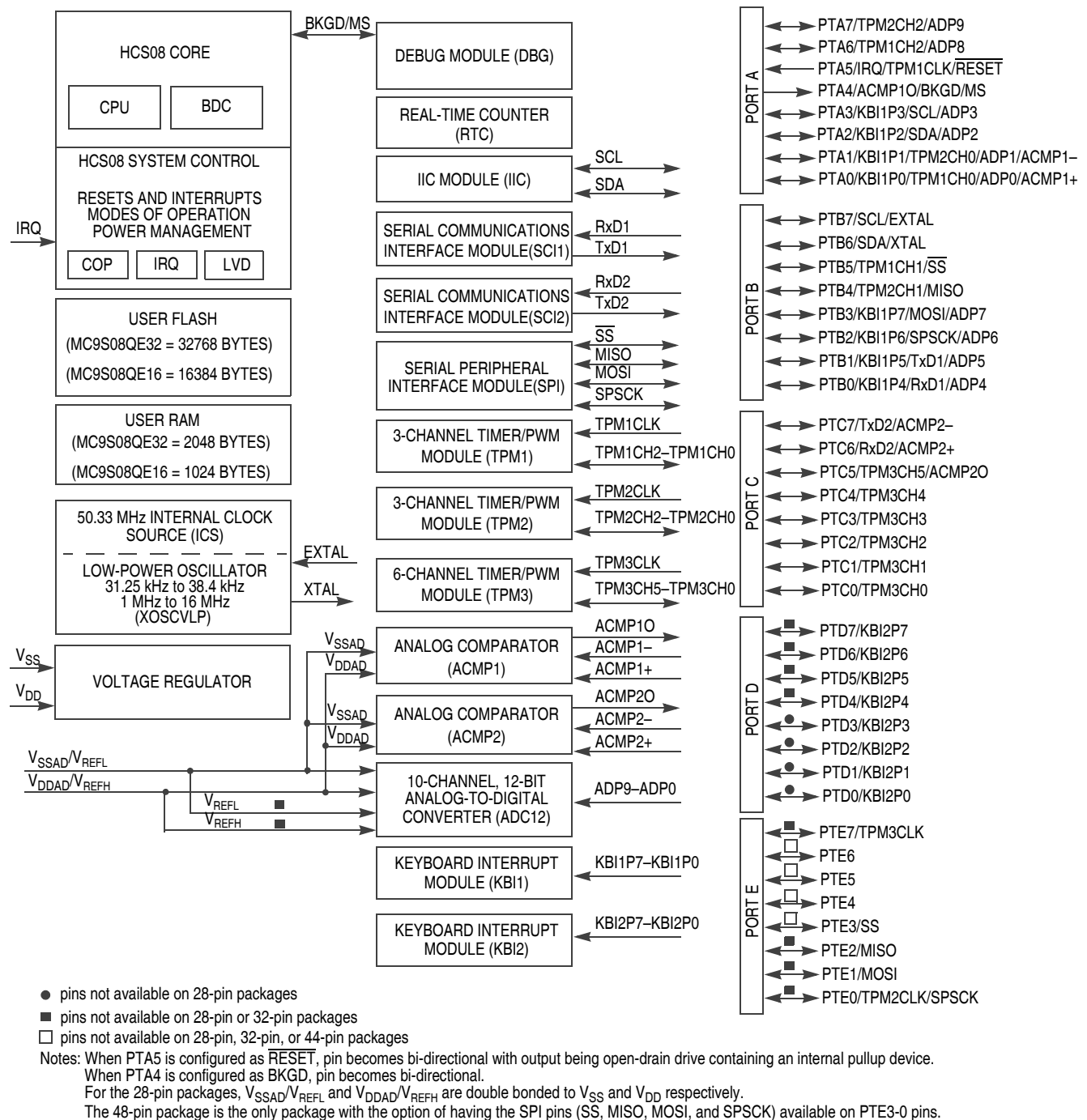
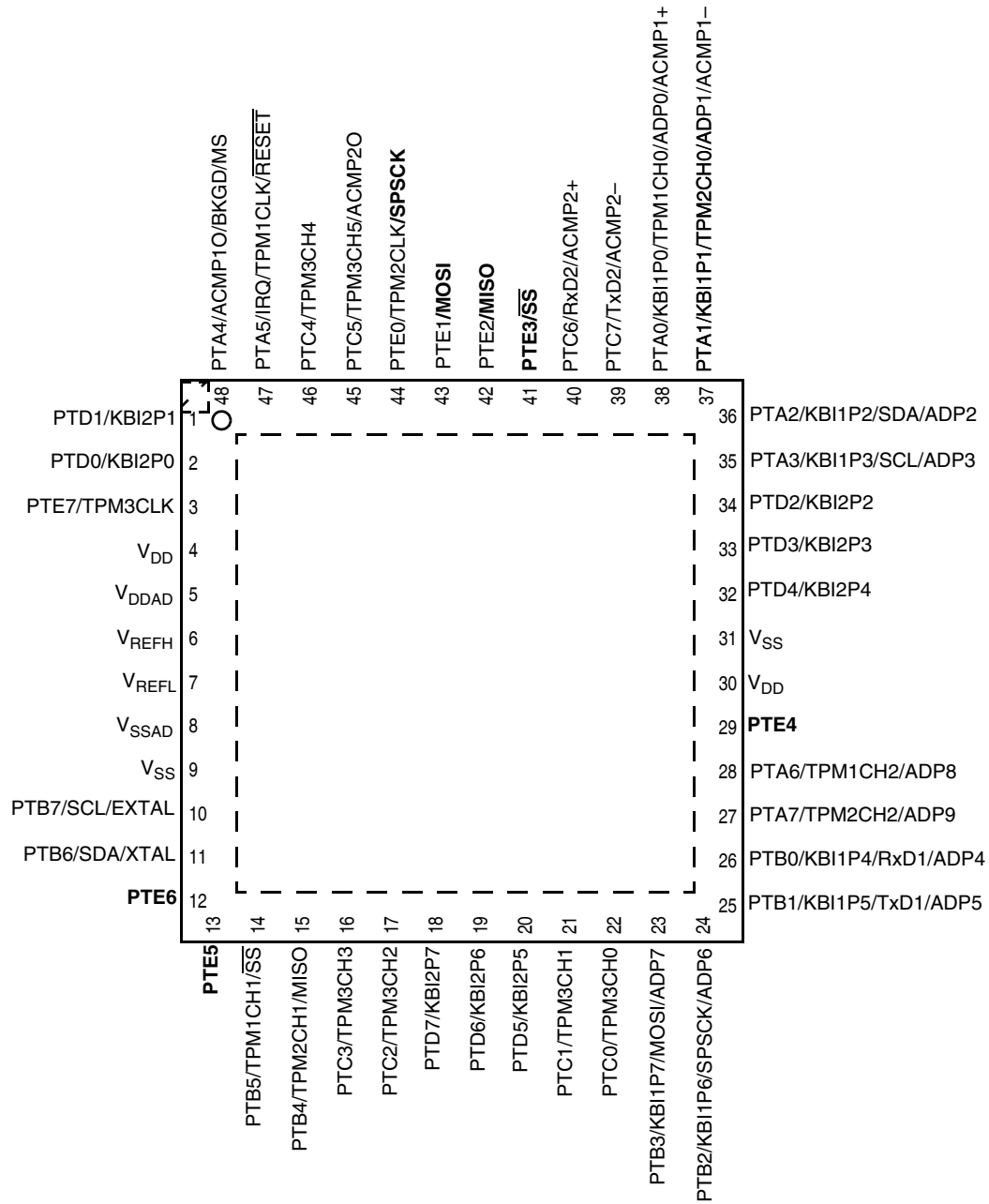

Figure 1. MC9S08QE32 Series Block Diagram

2 Pin Assignments

This section shows the pin assignments for the MC9S08QE32 series devices.



Pins in **bold** are lost in the next lower pin count package.

Figure 2. 48-Pin QFN

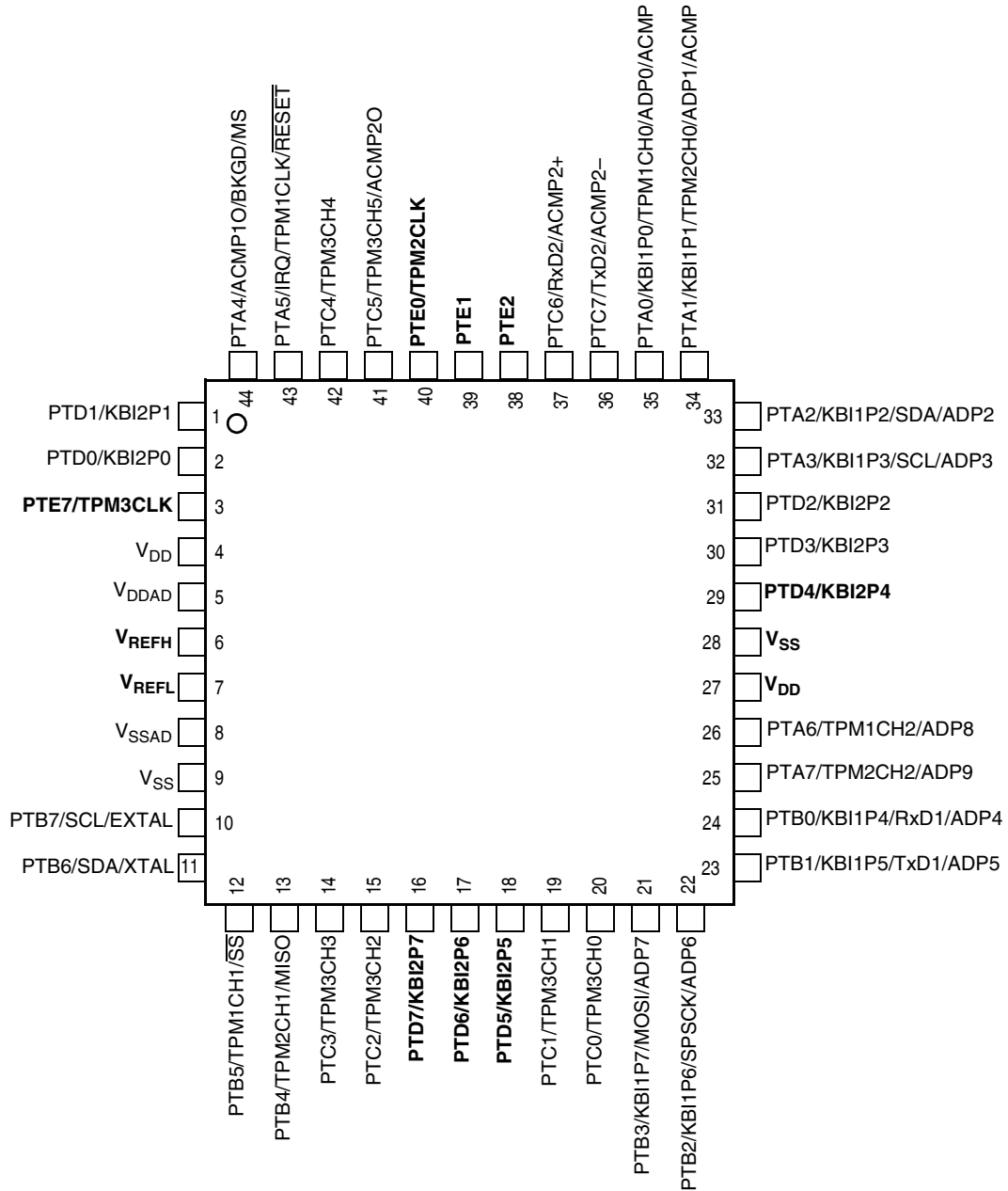

Pins in **bold** are lost in the next lower pin count package.

Figure 3. 44-Pin LQFP

Pin Assignments

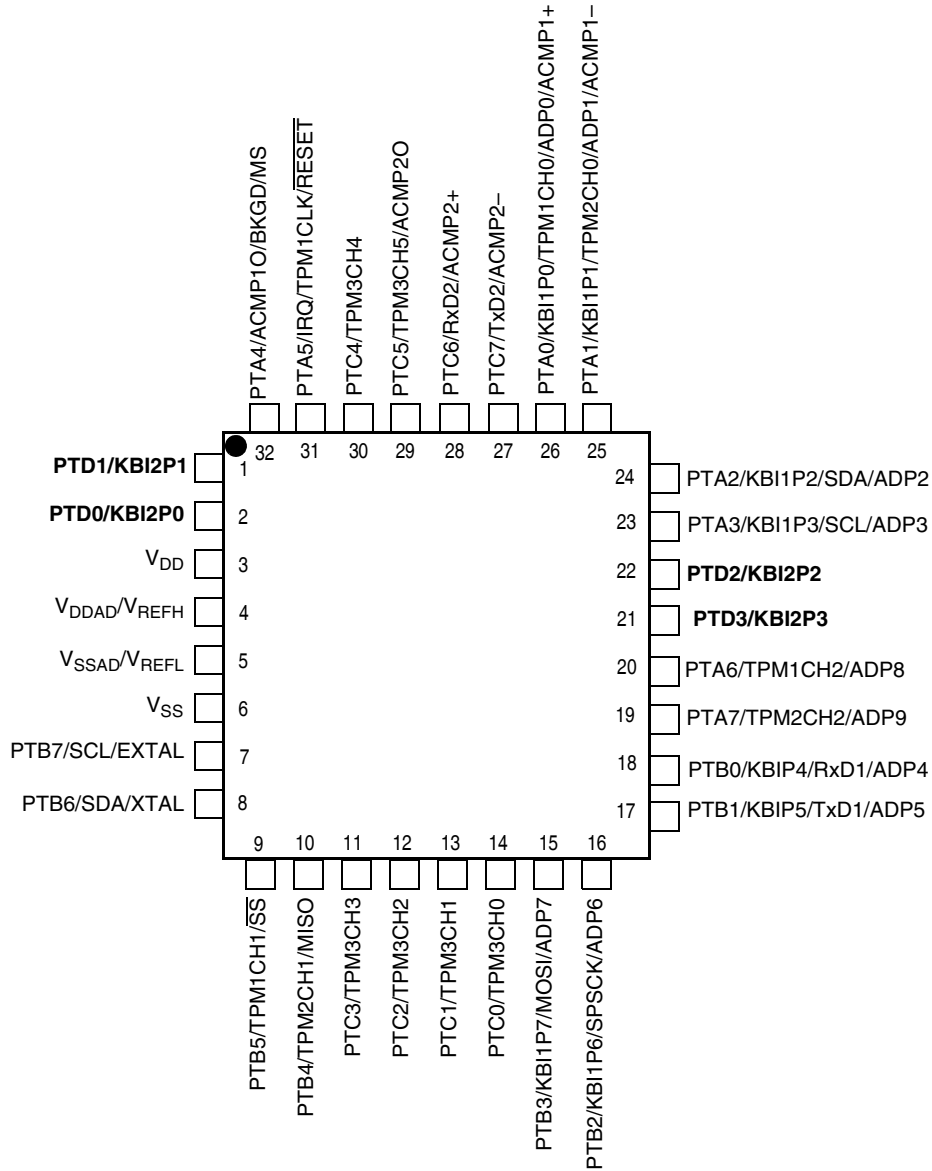

Pins in **bold** are lost in the next lower pin count package.

Figure 4. 32-Pin LQFP/QFN

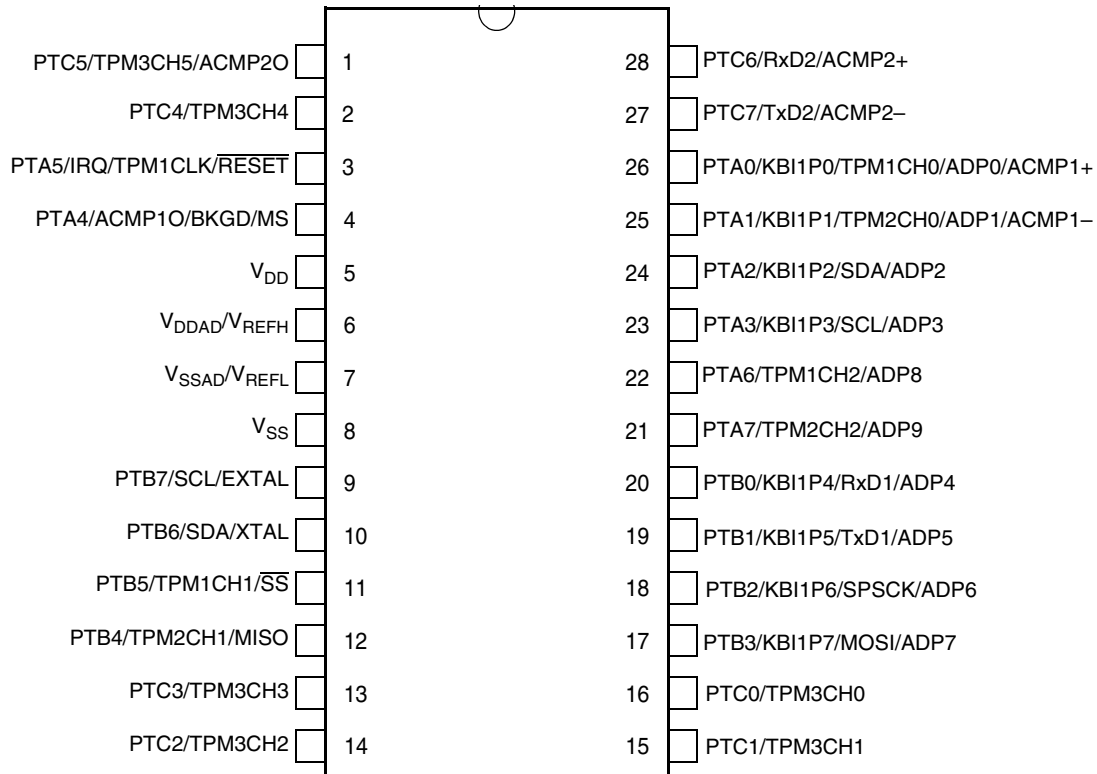

Figure 5. 28-Pin SOIC

Table 1. MC9S08QE32 Series Pin Assignment by Package and Pin Sharing Priority

Pin Number				<-- Lowest Priority --> Highest				
48	44	32	28	Port Pin	Alt 1	Alt 2	Alt 3	Alt 4
1	1	1	—	PTD1	KBI2P1			
2	2	2	—	PTD0	KBI2P0			
3	3	—	—	PTE7	TPM3CLK			
4	4	3	5					V _{DD}
5	5	4	6					V _{DDAD}
6	6							V _{REFH}
7	7	5	7					V _{REFL}
8	8							V _{SSAD}
9	9	6	8					V _{SS}
10	10	7	9	PTB7	SCL ¹			EXTAL
11	11	8	10	PTB6	SDA ¹			XTAL
12	—	—	—	PTE6				
13	—	—	—	PTE5				
14	12	9	11	PTB5	TPM1CH1	SS ²		
15	13	10	12	PTB4	TPM2CH1	MISO ²		
16	14	11	13	PTC3	TPM3CH3			
17	15	12	14	PTC2	TPM3CH2			
18	16	—	—	PTD7	KBI2P7			

Table 1. MC9S08QE32 Series Pin Assignment by Package and Pin Sharing Priority (continued)

Pin Number				<-- Lowest Priority --> Highest				
48	44	32	28	Port Pin	Alt 1	Alt 2	Alt 3	Alt 4
19	17	—	—	PTD6	KBI2P6			
20	18	—	—	PTD5	KBI2P5			
21	19	13	15	PTC1	TPM3CH1			
22	20	14	16	PTC0	TPM3CH0			
23	21	15	17	PTB3	KBI1P7	MOSI ²		ADP7
24	22	16	18	PTB2	KBI1P6	SPSCK ²		ADP6
25	23	17	19	PTB1	KBI1P5	TxD1		ADP5
26	24	18	20	PTB0	KBI1P4	RxD1		ADP4
27	25	19	21	PTA7	TPM2CH2			ADP9
28	26	20	22	PTA6	TPM1CH2			ADP8
29	—	—	—	PTE4				
30	27	—	—					V _{DD}
31	28	—	—					V _{SS}
32	29	—	—	PTD4	KBI2P4			
33	30	21	—	PTD3	KBI2P3			
34	31	22	—	PTD2	KBI2P2			
35	32	23	23	PTA3	KBI1P3	SCL ¹		ADP3
36	33	24	24	PTA2	KBI1P2	SDA ¹		ADP2
37	34	25	25	PTA1	KBI1P1	TPM2CH0	ADP1 ³	ACMP1– ³
38	35	26	26	PTA0	KBI1P0	TPM1CH0	ADP0 ³	ACMP1+ ³
39	36	27	27	PTC7	TxD2			ACMP2–
40	37	28	28	PTC6	RxD2			ACMP2+
41	—	—	—	PTE3	\overline{SS} ²			
42	38	—	—	PTE2	MISO ²			
43	39	—	—	PTE1	MOSI ²			
44	40	—	—	PTE0	TPM2CLK	SPSCK ²		
45	41	29	1	PTC5	TPM3CH5			ACMP2O
46	42	30	2	PTC4	TPM3CH4			
47	43	31	3	PTA5	IRQ	TPM1CLK	\overline{RESET}	
48	44	32	4	PTA4	ACMP1O	BKGD	MS	

¹ IIC pins, SCL and SDA can be repositioned using IICPS in SOPT2; default reset locations are PTA3 and PTA2.

² SPI pins (\overline{SS} , MISO, MOSI, and SPSCK) can be repositioned using SPIPS in SOPT2. Default locations are PTB5, PTB4, PTB3, and PTB2.

³ If ADC and ACMP1 are enabled, both modules will have access to the pin.

3 Electrical Characteristics

3.1 Introduction

This section contains electrical and timing specifications for the MC9S08QE32 series of microcontrollers available at the time of publication.

3.2 Parameter Classification

The electrical parameters shown in this supplement are guaranteed by various methods. To give the customer a better understanding the following classification is used and the parameters are tagged accordingly in the tables where appropriate:

Table 2. Parameter Classifications

P	Those parameters are guaranteed during production testing on each individual device.
C	Those parameters are achieved by the design characterization by measuring a statistically relevant sample size across process variations.
T	Those parameters are achieved by design characterization on a small sample size from typical devices under typical conditions unless otherwise noted. All values shown in the typical column are within this category.
D	Those parameters are derived mainly from simulations.

NOTE

The classification is shown in the column labeled “C” in the parameter tables where appropriate.

3.3 Absolute Maximum Ratings

Absolute maximum ratings are stress ratings only, and functional operation at the maxima is not guaranteed. Stress beyond the limits specified in [Table 3](#) may affect device reliability or cause permanent damage to the device. For functional operating conditions, refer to the remaining tables in this section.

This device contains circuitry protecting against damage due to high static voltage or electrical fields; however, it is advised that normal precautions be taken to avoid application of any voltages higher than maximum-rated voltages to this high-impedance circuit. Reliability of operation is enhanced if unused inputs are tied to an appropriate logic voltage level (for instance, either V_{SS} or V_{DD}) or the programmable pull-up resistor associated with the pin is enabled.

Table 3. Absolute Maximum Ratings

Rating	Symbol	Value	Unit
Supply voltage	V_{DD}	-0.3 to +3.8	V
Maximum current into V_{DD}	I_{DD}	120	mA
Digital input voltage	V_{In}	-0.3 to $V_{DD} + 0.3$	V
Instantaneous maximum current Single pin limit (applies to all port pins) ^{1, 2, 3}	I_D	±25	mA
Storage temperature range	T_{stg}	-55 to 150	°C

¹ Input must be current limited to the value specified. To determine the value of the required current-limiting resistor, calculate resistance values for positive (V_{DD}) and negative (V_{SS}) clamp voltages, then use the larger of the two resistance values.

² All functional non-supply pins, except for PTA5 are internally clamped to V_{SS} and V_{DD} .

³ Power supply must maintain regulation within operating V_{DD} range during instantaneous and operating maximum current conditions. If positive injection current ($V_{In} > V_{DD}$) is greater than I_{DD} , the injection current may flow out of V_{DD} and could result in external power supply going out of regulation. Ensure external V_{DD} load will shunt current greater than maximum injection current. This will be the greatest risk when the MCU is not consuming power. Examples are: if no system clock is present, or if the clock rate is very low (which would reduce overall power consumption).

3.4 Thermal Characteristics

This section provides information about operating temperature range, power dissipation, and package thermal resistance. Power dissipation on I/O pins is usually small compared to the power dissipation in on-chip logic and voltage regulator circuits, and it is user-determined rather than being controlled by the MCU design. To take $P_{I/O}$ into account in power calculations, determine the difference between actual pin voltage and V_{SS} or V_{DD} and multiply by the pin current for each I/O pin. Except in cases of unusually high pin current (heavy loads), the difference between pin voltage and V_{SS} or V_{DD} will be very small.

Table 4. Thermal Characteristics

Rating	Symbol	Value	Unit
Operating temperature range (packaged)	T_A	T_L to T_H -40 to 85	°C
Maximum junction temperature	T_{JM}	95	°C
Thermal resistance Single-layer board			
48-pin QFN	θ_{JA}	81	°C/W
44-pin LQFP		68	
32-pin LQFP		66	
32-pin QFN		92	
28-pin SOIC		57	
Thermal resistance Four-layer board			
48-pin QFN	θ_{JA}	26	°C/W
44-pin LQFP		46	
32-pin LQFP		54	
32-pin QFN		33	
28-pin SOIC		42	

The average chip-junction temperature (T_J) in °C can be obtained from:

$$T_J = T_A + (P_D \times \theta_{JA}) \quad \text{Eqn. 1}$$

where:

T_A = Ambient temperature, °C

θ_{JA} = Package thermal resistance, junction-to-ambient, °C/W

$P_D = P_{int} + P_{I/O}$

$P_{int} = I_{DD} \times V_{DD}$, Watts — chip internal power

$P_{I/O}$ = Power dissipation on input and output pins — user determined

For most applications, $P_{I/O} \ll P_{int}$ and can be neglected. An approximate relationship between P_D and T_J (if $P_{I/O}$ is neglected) is:

$$P_D = K \div (T_J + 273^\circ\text{C}) \quad \text{Eqn. 2}$$

Solving Equation 1 and Equation 2 for K gives:

$$K = P_D \times (T_A + 273^\circ\text{C}) + \theta_{JA} \times (P_D)^2 \quad \text{Eqn. 3}$$

where K is a constant pertaining to the particular part. K can be determined from equation 3 by measuring P_D (at equilibrium) for a known T_A . Using this value of K, the values of P_D and T_J can be obtained by solving Equation 1 and Equation 2 iteratively for any value of T_A .

3.5 ESD Protection and Latch-Up Immunity

Although damage from electrostatic discharge (ESD) is much less common on these devices than on early CMOS circuits, normal handling precautions must be used to avoid exposure to static discharge. Qualification tests are performed to ensure that these devices can withstand exposure to reasonable levels of static without suffering any permanent damage.

All ESD testing is in conformity with AEC-Q100 Stress Test Qualification for Automotive Grade Integrated Circuits. During the device qualification ESD stresses were performed for the human body model (HBM), the machine model (MM) and the charge device model (CDM).

A device is defined as a failure if after exposure to ESD pulses the device no longer meets the device specification. Complete DC parametric and functional testing is performed per the applicable device specification at room temperature followed by hot temperature, unless specified otherwise in the device specification.

Table 5. ESD and Latch-up Test Conditions

Model	Description	Symbol	Value	Unit
Human Body	Series resistance	R1	1500	Ω
	Storage capacitance	C	100	pF
	Number of pulses per pin	—	3	
Machine	Series resistance	R1	0	Ω
	Storage capacitance	C	200	pF
	Number of pulses per pin	—	3	
Latch-up	Minimum input voltage limit		-2.5	V
	Maximum input voltage limit		7.5	V

Table 6. ESD and Latch-Up Protection Characteristics

No.	Rating ¹	Symbol	Min	Max	Unit
1	Human body model (HBM)	V_{HBM}	± 2000	—	V
2	Machine model (MM)	V_{MM}	± 200	—	V
3	Charge device model (CDM)	V_{CDM}	± 500	—	V
4	Latch-up current at $T_A = 85^\circ\text{C}$	I_{LAT}	± 100	—	mA

¹ Parameter is achieved by design characterization on a small sample size from typical devices under typical conditions unless otherwise noted.

3.6 DC Characteristics

This section includes information about power supply requirements and I/O pin characteristics.

Table 7. DC Characteristics

Num	C	Characteristic	Symbol	Condition	Min	Typical ¹	Max	Unit
1		Operating Voltage V _{DD} rising V _{DD} falling			2.0 1.8	—	3.6	V
2	C	Output high voltage ² All I/O pins, low-drive strength	V _{OH}	1.8 V, I _{Load} = -2 mA	V _{DD} - 0.5	—	—	V
	P			2.7 V, I _{Load} = -10 mA	V _{DD} - 0.5	—	—	
	T	2.3 V, I _{Load} = -6 mA		V _{DD} - 0.5	—	—		
	C	1.8 V, I _{Load} = -3 mA		V _{DD} - 0.5	—	—		
3	D	Output high current Max total I _{OH} for all ports	I _{OHT}		—	—	100	mA
4	C	Output low voltage All I/O pins, low-drive strength	V _{OL}	1.8 V, I _{Load} = 2 mA	—	—	0.5	V
	P			2.7 V, I _{Load} = 10 mA	—	—	0.5	
	T	2.3 V, I _{Load} = 6 mA		—	—	0.5		
	C	1.8 V, I _{Load} = 3 mA		—	—	0.5		
5	D	Output low current Max total I _{OL} for all ports	I _{OLT}		—	—	100	mA
6	P	Input high voltage all digital inputs	V _{IH}	V _{DD} > 2.3 V	0.70 x V _{DD}	—	—	V
	C			V _{DD} ≤ 1.8 V	0.85 x V _{DD}	—	—	
7	P	Input low voltage all digital inputs	V _{IL}	V _{DD} > 2.7 V	—	—	0.35 x V _{DD}	
	C			V _{DD} ≤ 1.8 V	—	—	0.30 x V _{DD}	
8	C	Input hysteresis all digital inputs	V _{hys}		0.06 x V _{DD}	—	—	mV
9	P	Input leakage current all input only pins (Per pin)	I _{In}	V _{In} = V _{DD} or V _{SS}	—	—	1	μA
10	P	Hi-Z (off-state) leakage current all input/output (per pin)	I _{OZ}	V _{In} = V _{DD} or V _{SS}	—	—	1	μA
11	C	Total leakage combined for all inputs and Hi-Z pins All input only and I/O	I _{OZTOT}	V _{In} = V _{DD} or V _{SS}	—	—	2	μA
11	P	Pullup, Pulldown resistors all digital inputs, when enabled	R _{PU} , R _{PD}		17.5	—	52.5	kΩ
12	D	DC injection current ^{3, 4, 5} Single pin limit Total MCU limit, includes sum of all stressed pins	I _{IC}	V _{IN} < V _{SS} , V _{IN} > V _{DD}	-0.2	—	0.2	mA
					-5	—	5	mA
13	C	Input Capacitance, all pins	C _{In}		—	—	8	pF
14	C	RAM retention voltage	V _{RAM}		—	0.6	1.0	V
15	C	POR re-arm voltage ⁶	V _{POR}		0.9	1.4	2.0	V

Table 7. DC Characteristics (continued)

Num	C	Characteristic	Symbol	Condition	Min	Typical ¹	Max	Unit
16	D	POR re-arm time	t_{POR}		10	—	—	μs
17	P	Low-voltage detection threshold — high range	V_{LVDH}	V_{DD} falling V_{DD} rising	2.11 2.16	2.16 2.21	2.22 2.27	V
18	P	Low-voltage detection threshold — low range	V_{LVDL}	V_{DD} falling V_{DD} rising	1.80 1.88	1.82 1.90	1.91 1.99	V
19	P	Low-voltage warning threshold — high range	V_{LVWH}	V_{DD} falling V_{DD} rising	2.36 2.36	2.46 2.46	2.56 2.56	V
20	P	Low-voltage warning threshold — low range	V_{LVWL}	V_{DD} falling V_{DD} rising	2.11 2.16	2.16 2.21	2.22 2.27	V
21	C	Low-voltage inhibit reset/recover hysteresis	V_{hys}		—	80	—	mV
22	P	Bandgap Voltage Reference ⁷	V_{BG}		1.15	1.17	1.18	V

¹ Typical values are measured at 25 °C. Characterized, not tested

² As the supply voltage rises, the LVD circuit will hold the MCU in reset until the supply has risen above V_{LVDL} .

³ All functional non-supply pins, except for PTA5 are internally clamped to V_{SS} and V_{DD} .

⁴ Input must be current limited to the value specified. To determine the value of the required current-limiting resistor, calculate resistance values for positive and negative clamp voltages, then use the larger of the two values.

⁵ Power supply must maintain regulation within operating V_{DD} range during instantaneous and operating maximum current conditions. If positive injection current ($V_{in} > V_{DD}$) is greater than I_{DD} , the injection current may flow out of V_{DD} and could result in external power supply going out of regulation. Ensure external V_{DD} load will shunt current greater than maximum injection current. This will be the greatest risk when the MCU is not consuming power. Examples are: if no system clock is present, or if clock rate is very low (which would reduce overall power consumption).

⁶ Maximum is highest voltage that POR is guaranteed.

⁷ Factory trimmed at $V_{DD} = 3.0$ V, Temp = 25 °C

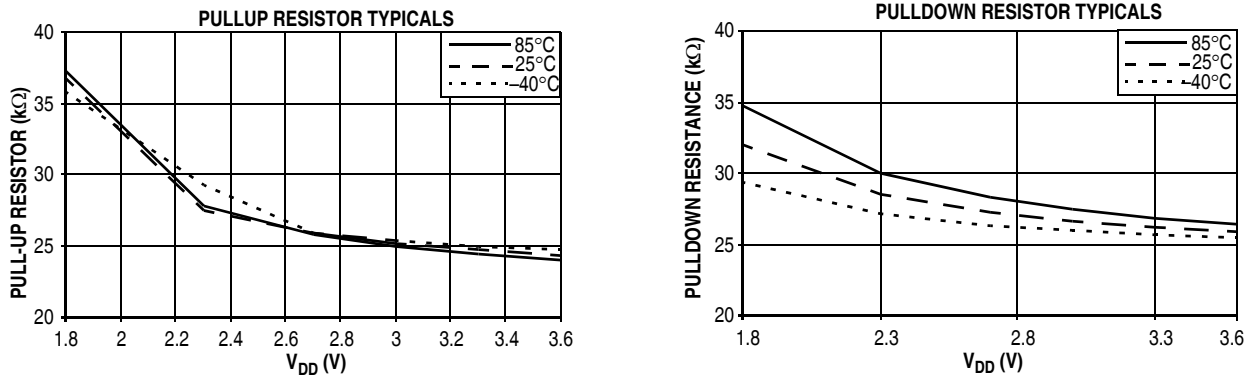

Figure 6. Pullup and Pulldown Typical Resistor Values ($V_{DD} = 3.0$ V)

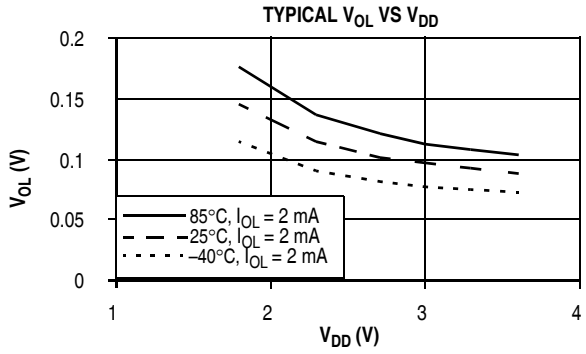
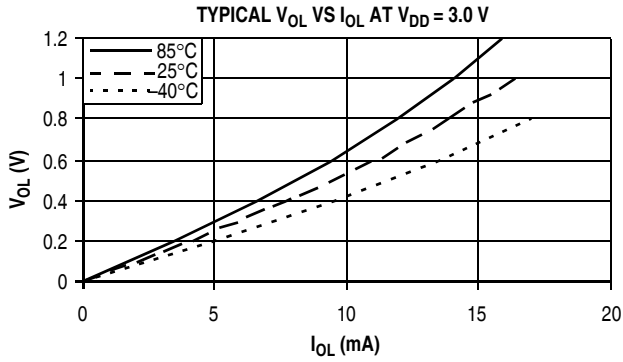

Figure 7. Typical Low-Side Driver (Sink) Characteristics — Low Drive (PTxDSn = 0)

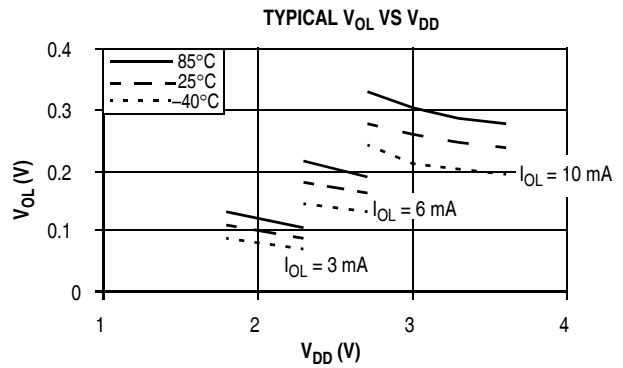
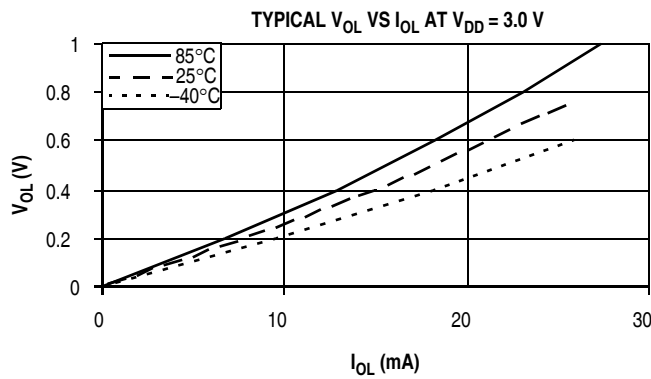

Figure 8. Typical Low-Side Driver (Sink) Characteristics — High Drive (PTxDSn = 1)

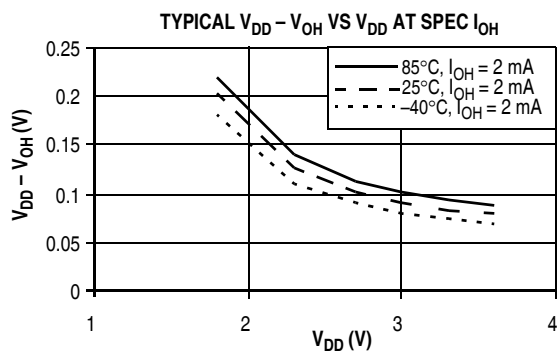
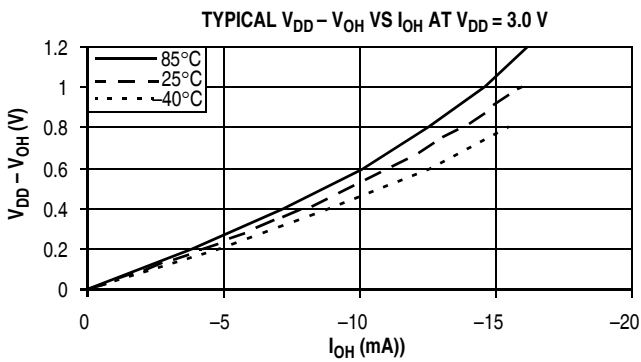

Figure 9. Typical High-Side (Source) Characteristics — Low Drive (PTxDSn = 0)

Electrical Characteristics

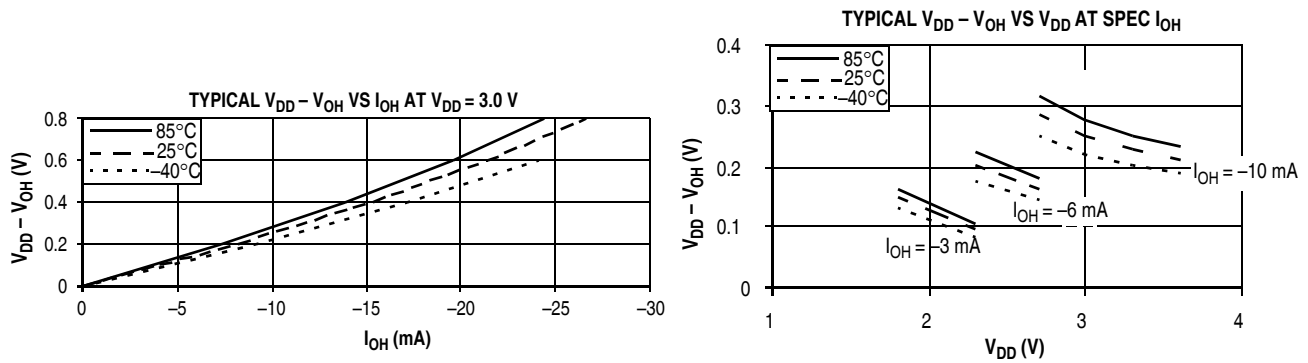

Figure 10. Typical High-Side (Source) Characteristics — High Drive (PTxDSn = 1)

3.7 Supply Current Characteristics

This section includes information about power supply current in various operating modes.

Table 8. Supply Current Characteristics

Num	C	Parameter	Symbol	Bus Freq	V _{DD} (V)	Typical ¹	Max	Unit	Temp (°C)	
1	P	Run supply current FEI mode, all modules on	R _I DD	25.165 MHz	3	13	14	mA	-40 to 25	
	P					14	15		85	
	T					20 MHz	13.75		—	-40 to 85
	T					8 MHz	5.59		—	
	T					1 MHz	1.03		—	
2	C	Run supply current FEI mode, all modules off	R _I DD	25.165 MHz	3	11.5	12.3	mA	-40 to 85	
	T					20 MHz	9.5			—
	T					8 MHz	4.6			—
	T					1 MHz	1.0			—
3	T	Run supply current LPRS = 0, all modules off	R _I DD	16 kHz FBILP	3	152	—	μA	-40 to 85	
	T			16 kHz FBELP		115	—			
4	T	Run supply current LPRS = 1, all modules off, running from Flash	R _I DD	16 kHz FBELP	3	21.9	—	μA	-40 to 85	
	T	Run supply current LPRS = 1, all modules off, running from RAM				7.3	—			
5	C	Wait mode supply current FEI mode, all modules off	W _I DD	25.165 MHz	3	5.74	6.00	mA	-40 to 85	
	T					20 MHz	4.57			—
	T					8 MHz	2			—
	T					1 MHz	0.73			—

Table 8. Supply Current Characteristics (continued)

Num	C	Parameter	Symbol	Bus Freq	V _{DD} (V)	Typical ¹	Max	Unit	Temp (°C)	
6	P	Stop2 mode supply current	S2I _{DD}	—	3	0.35	0.65	μA	–40 to 25C	
	C			—		0.8	1.0		70	
	P			—		2.0	4.5		85	
	C			—	2	0.25	0.50		–40 to 25	
	C			—		0.65	0.85		70	
	C			—		1.5	3.5		85	
7	P	Stop3 mode supply current no clocks active	S3I _{DD}	—	3	0.45	1.00	μA	–40 to 25	
	C			—		1.5	2.3		70	
	P			—		4	8		85	
	C			—	2	0.35	0.70		–40 to 25	
	C			—		1	2		70	
	C			—		3.5	6.0		85	
8	T	Low power mode adders:	EREFSTEN=1	32 kHz	3	500	—	nA	–40 to 85	
9	T		IREFSTEN=1	32 kHz		70	—			μA
10	T		TPM PWM	100 Hz		12	—			μA
11	T		SCI, SPI, or IIC	300 bps		15	—			μA
12	T		RTC using LPO	1 kHz		200	—			nA
13	T		RTC using ICSERCLK	32 kHz		1	—			μA
14	T		LVD	n/a		100	—			μA
15	T		ACMP	n/a		20	—			μA

¹ Data in Typical column was characterized at 3.0 V, 25 °C or is typical recommended value.

Table 9. Stop Mode Adders

Num	C	Parameter	Condition	Temperature				Units
				–40°C	25°C	70°C	85°C	
1	T	LPO	—	50	75	100	150	nA
2	T	EREFSTEN	RANGE = HGO = 0	1000	1000	1100	1500	nA
3	T	IREFSTEN ¹	—	63	70	77	81	μA
4	T	RTC	Does not include clock source current	50	75	100	150	nA
5	T	LVD ¹	LVDSE = 1	90	100	110	115	μA
6	T	ACMP ¹	Not using the bandgap (BGBE = 0)	18	20	22	23	μA
7	T	ADC ¹	ADLPC = ADLSMP = 1 Not using the bandgap (BGBE = 0)	95	106	114	120	μA

Electrical Characteristics

¹ Not available in stop2 mode.

3.8 External Oscillator (XOSCVLP) Characteristics

Reference [Figure 11](#) and [Figure 12](#) for crystal or resonator circuits.

Table 10. XOSC and ICS Specifications (Temperature Range = -40 to 85°C Ambient)

Num	C	Characteristic	Symbol	Min	Typical ¹	Max	Unit
1	C	Oscillator crystal or resonator (EREFS = 1, ERCLKEN = 1)					
		Low range (RANGE = 0)	f_{lo}	32	—	38.4	kHz
		High range (RANGE = 1), high gain (HGO = 1)	f_{hi}	1	—	16	MHz
		High range (RANGE = 1), low power (HGO = 0)	f_{hi}	1	—	8	MHz
2	D	Load capacitors					
		Low range (RANGE=0), low power (HGO=0) Other oscillator settings	C_1 C_2		See Note ² See Note ³		
3	D	Feedback resistor					
		Low range, low power (RANGE=0, HGO=0) ²	R_F	—	—	—	M Ω
		Low range, High Gain (RANGE=0, HGO=1)		—	10	—	
High range (RANGE=1, HGO=X)	—	1		—			
4	D	Series resistor —					
		Low range, low power (RANGE = 0, HGO = 0) ²	R_S	—	—	—	k Ω
		Low range, high gain (RANGE = 0, HGO = 1)		—	100	—	
		High range, low power (RANGE = 1, HGO = 0)		—	0	—	
		High range, high gain (RANGE = 1, HGO = 1)		—	0	0	
		≥ 8 MHz		—	0	10	
4 MHz	—	0		20			
		1 MHz	—	0	20		
5	C	Crystal start-up time ⁴					
		Low range, low power	t_{CSTL}	—	200	—	ms
		Low range, high power		—	400	—	
		High range, low power	t_{CSTH}	—	5	—	
High range, high power		—	15	—			
6	D	Square wave input clock frequency (EREFS = 0, ERCLKEN = 1)					
		FEE mode	f_{extal}	0.03125	—	40	MHz
		FBE or FBELP mode		0	—	40	MHz

¹ Data in Typical column is characterized at 3.0 V, 25 °C or is typical recommended value.

² Load capacitors (C_1, C_2), feedback resistor (R_F) and series resistor (R_S) are incorporated internally when RANGE=HGO=0.

³ See crystal or resonator manufacturer's recommendation.

⁴ Proper PC board layout procedures must be followed to achieve specifications.

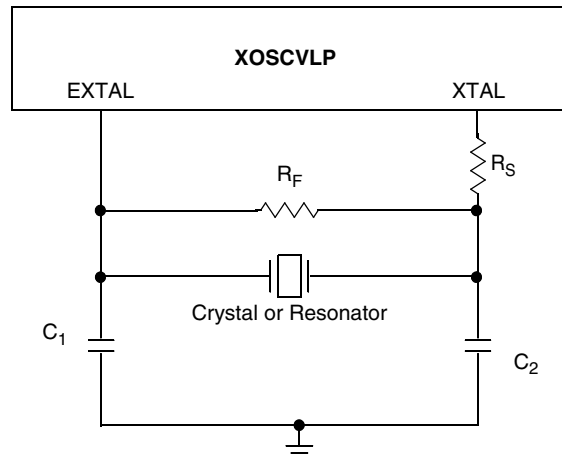

Figure 11. Typical Crystal or Resonator Circuit: High Range and Low Range/High Gain

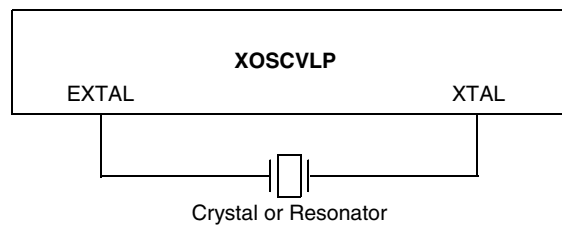

Figure 12. Typical Crystal or Resonator Circuit: Low Range/Low Power

3.9 Internal Clock Source (ICS) Characteristics

Table 11. ICS Frequency Specifications (Temperature Range = -40 to 85°C Ambient)

Num	C	Characteristic	Symbol	Min	Typical ¹	Max	Unit	
1	P	Average internal reference frequency — factory trimmed	f_{int_t}	—	32.768	—	kHz	
2	C	Average internal reference frequency — untrimmed	f_{int_ut}	31.25	—	39.06	kHz	
3	T	Internal reference start-up time	t_{IRST}	—	5	10	μ s	
4	P	DCO output frequency trimmed ²	f_{dco_u}	Low range (DFR = 00)	16	—	20	MHz
	P			Mid range (DFR = 01)	32	—	40	
	P			High range (DFR = 10)	48	—	60	
5	P	DCO output frequency ² reference = 32768 Hz and DMX32 = 1	f_{dco_DMX32}	Low range (DFR = 00)	—	19.92	—	MHz
	P			Mid range (DFR = 01)	—	39.85	—	
	P			High range (DFR = 10)	—	59.77	—	
6	C	Resolution of trimmed DCO output frequency at fixed voltage and temperature (using FTRIM)	$\Delta f_{dco_res_t}$	—	± 0.1	± 0.2	% f_{dco}	
7	C	Resolution of trimmed DCO output frequency at fixed voltage and temperature (not using FTRIM)	$\Delta f_{dco_res_t}$	—	± 0.2	± 0.4	% f_{dco}	

Table 11. ICS Frequency Specifications (Temperature Range = –40 to 85°C Ambient) (continued)

Num	C	Characteristic	Symbol	Min	Typical ¹	Max	Unit
8	C	Total deviation of trimmed DCO output frequency over voltage and temperature	Δf_{dco_t}	—	0.5 –1.0	±2	% f_{dco}
9	C	Total deviation of trimmed DCO output frequency over fixed voltage and temperature range of 0 °C to 70 °C	Δf_{dco_t}	—	±0.5	±1	% f_{dco}
10	C	FLL acquisition time ³	$t_{Acquire}$	—	—	1	ms
11	C	Long term jitter of DCO output clock (averaged over 2-ms interval) ⁴	C_{Jitter}	—	0.02	0.2	% f_{dco}

¹ Data in Typical column is characterized at 3.0 V, 25 °C or is typical recommended value.

² The resulting bus clock frequency must not exceed the maximum specified bus clock frequency of the device.

³ This specification applies to any time the FLL reference source or reference divider is changed, trim value changed or changing from FLL disabled (FBELP, FBILP) to FLL enabled (FEI, FEE, FBE, FBI). If a crystal/resonator is being used as the reference, this specification assumes it is already running.

⁴ Jitter is the average deviation from the programmed frequency measured over the specified interval at maximum f_{BUS} . Measurements are made with the device powered by filtered supplies and clocked by a stable external clock signal. Noise injected into the FLL circuitry via V_{DD} and V_{SS} and variation in crystal oscillator frequency increase the C_{Jitter} percentage for a given interval.

3.10 AC Characteristics

This section describes timing characteristics for each peripheral system.

3.10.1 Control Timing

Table 12. Control Timing

Num	C	Rating	Symbol	Min	Typical ¹	Max	Unit
1	D	Bus frequency ($t_{cyc} = 1/f_{Bus}$) $V_{DD} \leq 2.1V$ $2.1 < V_{DD} \leq 2.4V$ $V_{DD} > 2.4Vs$	f_{Bus}	DC	—	10 20 25.165	MHz
2	D	Internal low power oscillator period	t_{LPO}	700	—	1300	μs
3	D	External reset pulse width ²	t_{extrst}	100	—	—	ns
4	D	Reset low drive	t_{rstdrv}	$34 \times t_{cyc}$	—	—	ns
5	D	BKGD/MS setup time after issuing background debug force reset to enter user or BDM modes	t_{MSSU}	500	—	—	ns
6	D	BKGD/MS hold time after issuing background debug force reset to enter user or BDM modes ³	t_{MSH}	100	—	—	μs
7	D	IRQ pulse width Asynchronous path ² Synchronous path ⁴	t_{ILIH}, t_{IHIL}	100 $1.5 \times t_{cyc}$	— —	— —	ns

Table 12. Control Timing (continued)

Num	C	Rating	Symbol	Min	Typical ¹	Max	Unit
8	D	Keyboard interrupt pulse width Asynchronous path ² Synchronous path ⁵	t_{LILH} , t_{HIL}	100 $1.5 \times t_{cyc}$	— —	— —	ns
9	C	Port rise and fall time — Low output drive (PTxDS = 0) (load = 50 pF) ⁵ Slew rate control disabled (PTxSE = 0) Slew rate control enabled (PTxSE = 1)	t_{Rise} , t_{Fall}	— —	8 31	— —	ns
		Port rise and fall time — High output drive (PTxDS = 1) (load = 50 pF) Slew rate control disabled (PTxSE = 0) Slew rate control enabled (PTxSE = 1)	t_{Rise} , t_{Fall}	— —	7 24	— —	ns
10	C	Voltage regulator recovery time	t_{VRR}	—	4	—	μ s

¹ Typical values are based on characterization data at $V_{DD} = 3.0$ V, 25 °C unless otherwise stated.

² This is the shortest pulse that is guaranteed to be recognized as a reset pin request. Shorter pulses are not guaranteed to override reset requests from internal sources.

³ To enter BDM mode following a POR, BKGD/MS must be held low during the power-up and for a hold time of t_{MSH} after V_{DD} rises above V_{LVD} .

⁴ This is the minimum pulse width that is guaranteed to pass through the pin synchronization circuitry. Shorter pulses may or may not be recognized. In stop mode, the synchronizer is bypassed so shorter pulses can be recognized in that case.

⁵ Timing is shown with respect to 20% V_{DD} and 80% V_{DD} levels. Temperature range –40 °C to 85 °C.

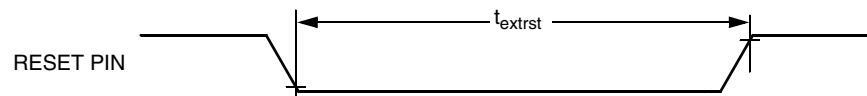
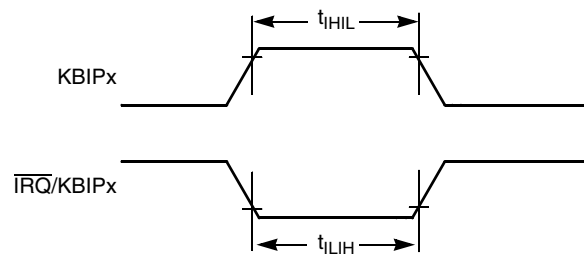

Figure 13. Reset Timing

Figure 14. $\overline{IRQ/KBIPx}$ Timing

3.10.2 TPM Module Timing

Synchronizer circuits determine the shortest input pulses that can be recognized or the fastest clock that can be used as the optional external source to the timer counter. These synchronizers operate from the current bus rate clock.

Table 13. TPM Input Timing

No.	C	Function	Symbol	Min	Max	Unit
1	D	External clock frequency	f_{TCLK}	0	$f_{Bus}/4$	Hz
2	D	External clock period	t_{TCLK}	4	—	t_{cyc}
3	D	External clock high time	t_{clkh}	1.5	—	t_{cyc}
4	D	External clock low time	t_{clkl}	1.5	—	t_{cyc}
5	D	Input capture pulse width	t_{ICPW}	1.5	—	t_{cyc}

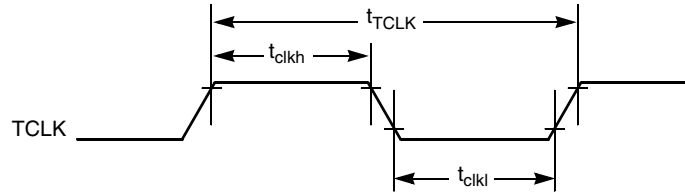

Figure 15. Timer External Clock

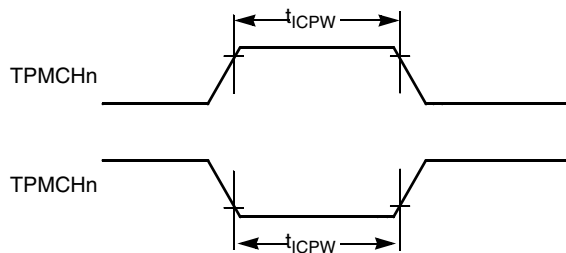

Figure 16. Timer Input Capture Pulse

3.10.3 SPI Timing

Table 14 and Figure 17 through Figure 20 describe the timing requirements for the SPI system.

Table 14. SPI Timing

No.	C	Function	Symbol	Min	Max	Unit
—	D	Operating frequency Master Slave	f_{op}	$f_{Bus}/2048$ 0	$f_{Bus}/2^1$ $f_{Bus}/4$	Hz
1	D	SPSCK period Master Slave	t_{SPSCK}	2 4	2048 —	t_{cyc} t_{cyc}
2	D	Enable lead time Master Slave	t_{Lead}	1/2 1	— —	t_{SPSCK} t_{cyc}
3	D	Enable lag time Master Slave	t_{Lag}	1/2 1	— —	t_{SPSCK} t_{cyc}

Table 14. SPI Timing (continued)

No.	C	Function	Symbol	Min	Max	Unit
4	D	Clock (SPSCK) high or low time Master Slave	t_{WSPSCK}	$t_{cyc} - 30$ $t_{cyc} - 30$	$1024 t_{cyc}$ —	ns ns
5	D	Data setup time (inputs) Master Slave	t_{SU}	15 15	— —	ns ns
6	D	Data hold time (inputs) Master Slave	t_{HI}	0 25	— —	ns ns
7	D	Slave access time	t_a	—	1	t_{cyc}
8	D	Slave MISO disable time	t_{dis}	—	1	t_{cyc}
9	D	Data valid (after SPSCK edge) Master Slave	t_v	— —	25 25	ns ns
10	D	Data hold time (outputs) Master Slave	t_{HO}	0 0	— —	ns ns
11	D	Rise time Input Output	t_{RI} t_{RO}	— —	$t_{cyc} - 25$ 25	ns ns
12	D	Fall time Input Output	t_{FI} t_{FO}	— —	$t_{cyc} - 25$ 25	ns ns

¹ Max operating frequency limited to 8 MHz when input filter disabled and high output drive strength enabled. Max operating frequency limited to 5 MHz when input filter enabled and high output drive strength disabled.

Electrical Characteristics

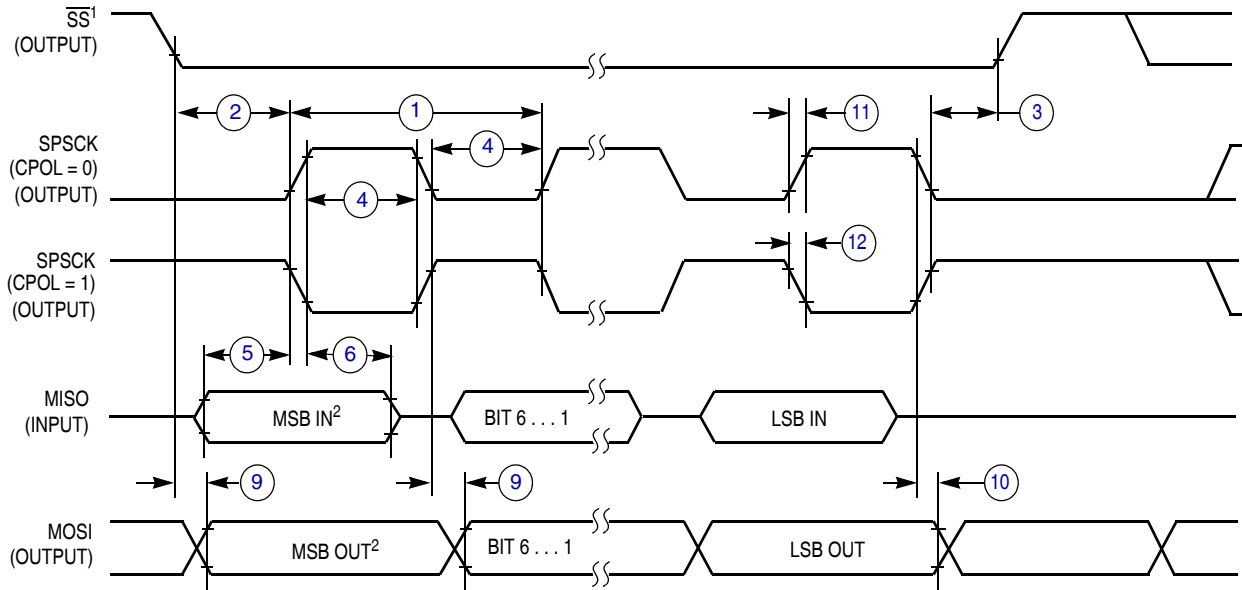

NOTES:

1. \overline{SS} output mode (DDS7 = 1, SSOE = 1).
2. LSBF = 0. For LSBF = 1, bit order is LSB, bit 1, ..., bit 6, MSB.

Figure 17. SPI Master Timing (CPHA = 0)

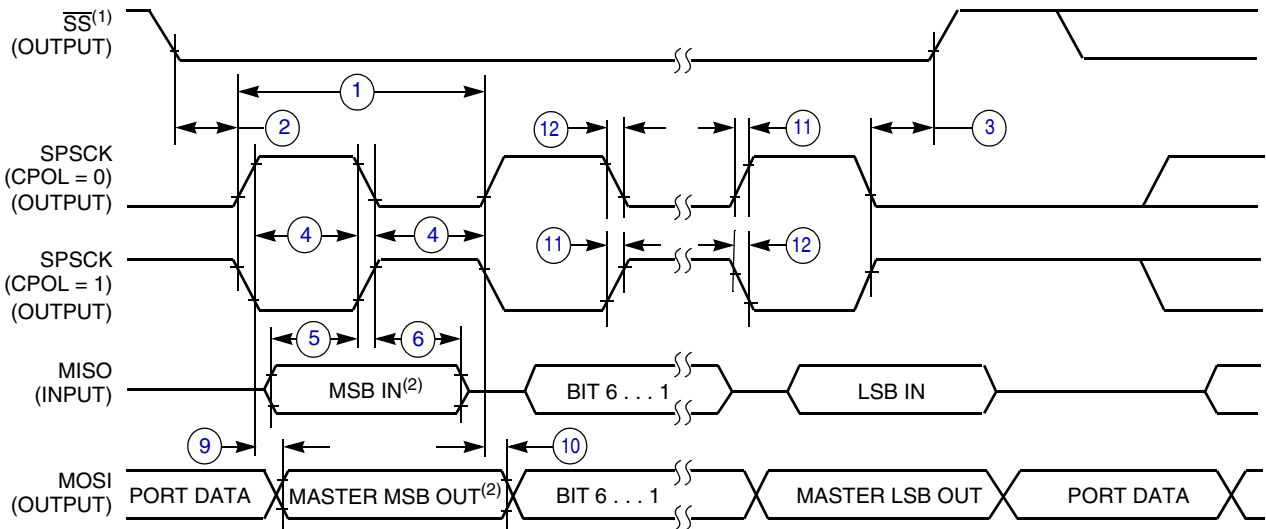

NOTES:

1. \overline{SS} output mode (DDS7 = 1, SSOE = 1).
2. LSBF = 0. For LSBF = 1, bit order is LSB, bit 1, ..., bit 6, MSB.

Figure 18. SPI Master Timing (CPHA = 1)

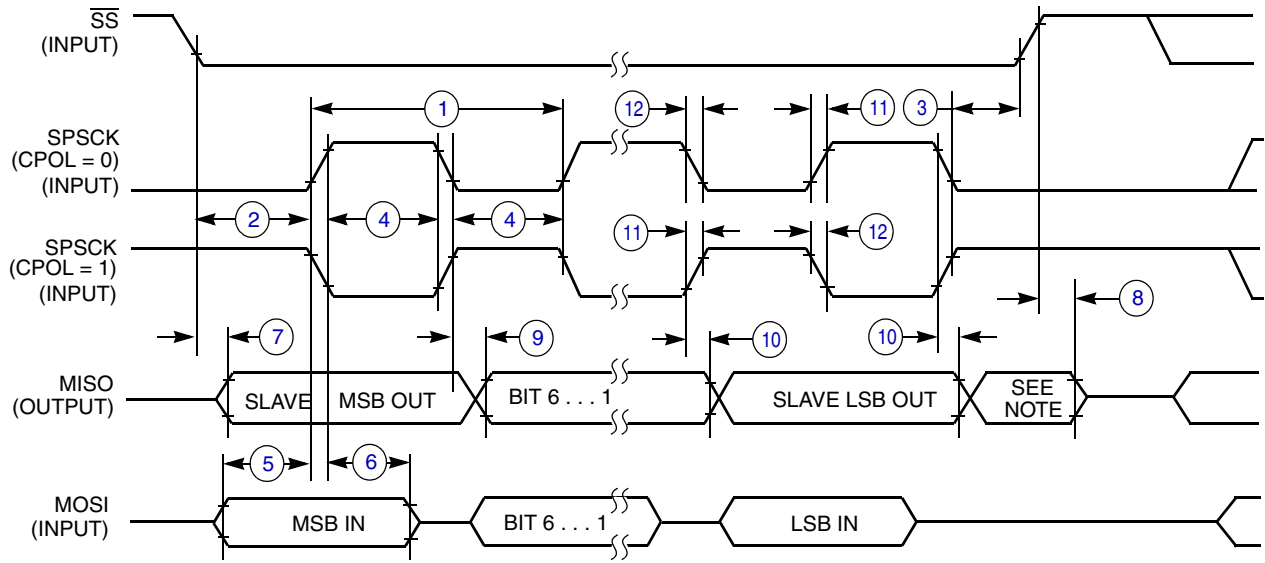

NOTE:

1. Not defined but normally MSB of character just received

Figure 19. SPI Slave Timing (CPHA = 0)

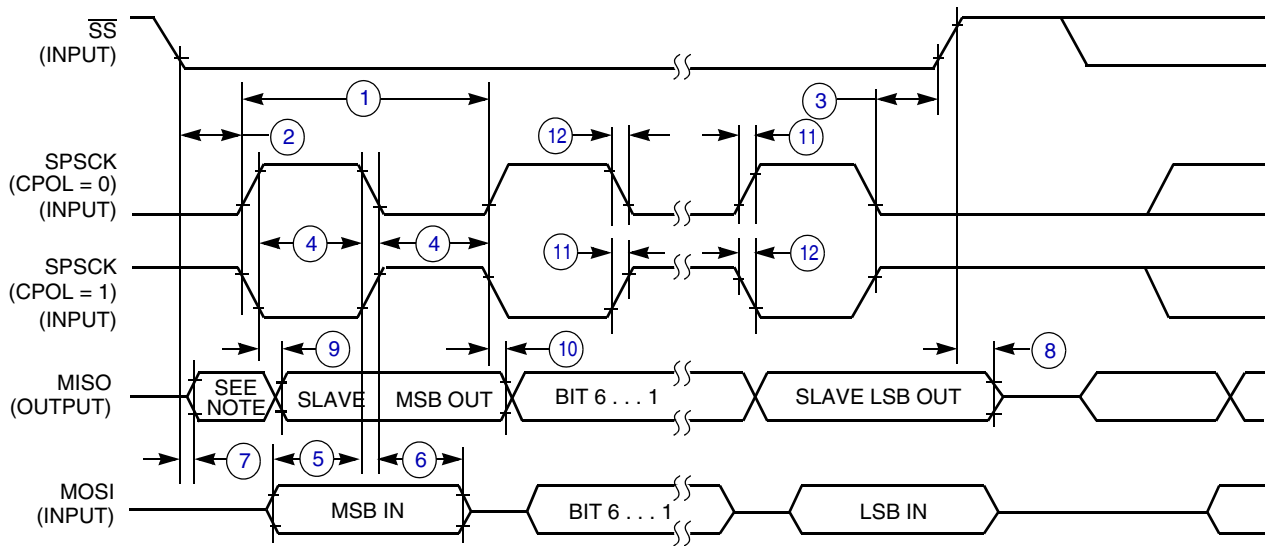

NOTE:

1. Not defined but normally LSB of character just received

Figure 20. SPI Slave Timing (CPHA = 1)

3.11 Analog Comparator (ACMP) Electricals

Table 15. Analog Comparator Electrical Specifications

C	Characteristic	Symbol	Min	Typical	Max	Unit
D	Supply voltage	V_{DD}	1.8	—	3.6	V
P	Supply current (active)	I_{DDAC}	—	20	35	μA
D	Analog input voltage	V_{AIN}	$V_{SS} - 0.3$	—	V_{DD}	V
P	Analog input offset voltage	V_{AIO}	—	20	40	mV
C	Analog comparator hysteresis	V_H	3.0	9.0	15.0	mV
P	Analog input leakage current	I_{ALKG}	—	—	1.0	μA
C	Analog comparator initialization delay	t_{AINIT}	—	—	1.0	μs

3.12 ADC Characteristics

Table 16. 12-Bit ADC Operating Conditions

C	Characteristic	Conditions	Symb	Min	Typical ¹	Max	Unit	Comment
D	Supply voltage	Absolute	V_{DDAD}	1.8	—	3.6	V	—
		Delta to V_{DD} ($V_{DD} - V_{DDAD}$) ²	ΔV_{DDAD}	-100	0	100	mV	—
D	Ground voltage	Delta to V_{SS} ($V_{SS} - V_{SSAD}$) ²	ΔV_{SSAD}	-100	0	100	mV	—
D	Input voltage	—	V_{ADIN}	V_{REFL}	—	V_{REFH}	V	—
C	Input capacitance	—	C_{ADIN}	—	4.5	5.5	pF	—
C	Input resistance	—	R_{ADIN}	—	5	7	k Ω	—
C	Analog source resistance	12-bit mode $f_{ADCK} > 4$ MHz $f_{ADCK} < 4$ MHz	R_{AS}	—	—	2	k Ω	External to MCU
		10-bit mode $f_{ADCK} > 4$ MHz $f_{ADCK} < 4$ MHz		—	—	5		
		8-bit mode (all valid f_{ADCK})		—	—	10		
D	ADC conversion clock freq.	High speed (ADLPC = 0)	f_{ADCK}	0.4	—	8.0	MHz	—
		Low power (ADLPC = 1)		0.4	—	4.0		

¹ Typical values assume $V_{DDAD} = 3.0$ V, Temp = 25 °C, $f_{ADCK} = 1.0$ MHz unless otherwise stated. Typical values are for reference only and are not tested in production.

² DC potential difference.

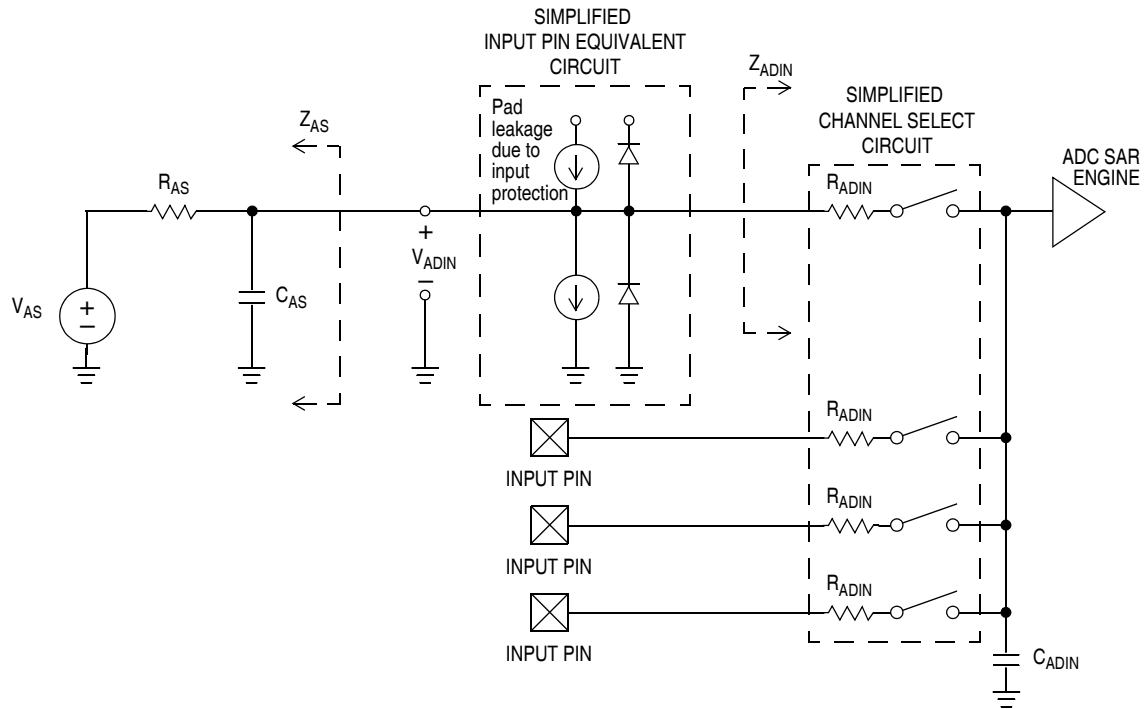

Figure 21. ADC Input Impedance Equivalency Diagram

Table 17. ADC Characteristics ($V_{REFH} = V_{DDAD}$, $V_{REFL} = V_{SSAD}$)

C	Characteristic	Conditions	Symbol	Min	Typ ¹	Max	Unit	Comment
T	Supply current ADLPC = 1 ADLSMP = 1 ADCO = 1		I_{DDAD}	—	120	—	μA	
T	Supply current ADLPC = 1 ADLSMP = 0 ADCO = 1		I_{DDAD}	—	202	—	μA	
T	Supply current ADLPC = 0 ADLSMP = 1 ADCO = 1		I_{DDAD}	—	288	—	μA	
P	Supply current ADLPC = 0 ADLSMP = 0 ADCO = 1		I_{DDAD}	—	0.532	1	mA	
P	ADC asynchronous clock source	High speed (ADLPC = 0)	f_{ADACK}	2	3.3	5	MHz	$t_{ADACK} = 1/f_{ADACK}$
		Low power (ADLPC = 1)		1.25	2	3.3		

Electrical Characteristics

Table 17. ADC Characteristics ($V_{REFH} = V_{DDAD}$, $V_{REFL} = V_{SSAD}$) (continued)

C	Characteristic	Conditions	Symbol	Min	Typ ¹	Max	Unit	Comment
P	Conversion time (including sample time)	Short sample (ADLSMP = 0)	t_{ADC}	—	20	—	ADCK cycles	See reference manual for conversion time variances
		Long sample (ADLSMP = 1)		—	40	—		
P	Sample time	Short sample (ADLSMP = 0)	t_{ADS}	—	3.5	—	ADCK cycles	
		Long sample (ADLSMP = 1)		—	23.5	—		
D	Temp sensor slope	-40 °C– 25 °C	m	—	1.646	—	mV/°C	
		25 °C– 85 °C		—	1.769	—		
D	Temp sensor voltage	25 °C	V_{TEMP25}	—	701.2	—	mV	
T	Total unadjusted error	12-bit mode, $3.6 > V_{DDAD} > 2.7$	E_{TUE}	—	-1 to 3	-2.5 to 5.5	LSB ²	Includes quantization
T		12-bit mode, $2.7 > V_{DDAD} > 1.8V$		—	-1 to 3	-3.0 to 6.5		
P		10-bit mode		—	±1	±2.5		
P		8-bit mode		—	±0.5	±1.0		
T	Differential non-linearity	12-bit mode	DNL	—	±1.0	-1.5 to 2.0	LSB ²	
P		10-bit mode ³		—	±0.5	±1.0		
P		8-bit mode ³		—	±0.3	±0.5		
T	Integral non-linearity	12-bit mode	INL	—	±1.5	-2.5 to 2.75	LSB ²	
T		10-bit mode		—	±0.5	±1.0		
T		8-bit mode		—	±0.3	±0.5		
T	Zero-scale error	12-bit mode	E_{ZS}	—	±1.5	±2.5	LSB ²	$V_{ADIN} = V_{SSAD}$
P		10-bit mode		—	±0.5	±1.5		
P		8-bit mode		—	±0.5	±0.5		
T	Full-scale error	12-bit mode	E_{FS}	—	±1.0	-3.5 to 1.0	LSB ²	$V_{ADIN} = V_{DDAD}$
P		10-bit mode		—	±0.5	±1		
P		8-bit mode		—	±0.5	±0.5		
D	Quantization error	12-bit mode	E_Q	—	-1 to 0	—	LSB ²	
		10-bit mode		—	—	±0.5		
		8-bit mode		—	—	±0.5		
D	Input leakage error	12-bit mode	E_{IL}	—	±2	—	LSB ²	Pad leakage ⁴ * R_{AS}
		10-bit mode		—	±0.2	±4		
		8-bit mode		—	±0.1	±1.2		

- ¹ Typical values assume $V_{DDAD} = 3.0\text{ V}$, $\text{Temp} = 25\text{ }^\circ\text{C}$, $f_{ADCK} = 1.0\text{ MHz}$ unless otherwise stated. Typical values are for reference only and are not tested in production.
- ² $1\text{ LSB} = (V_{REFH} - V_{REFL})/2^N$
- ³ Monotonicity and No-missing-codes guaranteed in 10-bit and 8-bit modes
- ⁴ Based on input pad leakage current. Refer to pad electricals.

3.13 Flash Specifications

This section provides details about program/erase times and program-erase endurance for flash memory. Program and erase operations do not require any special power sources other than the normal V_{DD} supply. For more detailed information about program/erase operations, see MC9S08QE32 Series Reference Manual Chapter 4 Memory.

Table 18. Flash Characteristics

C	Characteristic	Symbol	Min	Typical	Max	Unit
D	Supply voltage for program/erase -40 °C to 85 °C	$V_{\text{prog/erase}}$	1.8	—	3.6	V
D	Supply voltage for read operation	V_{Read}	1.8	—	3.6	V
D	Internal FCLK frequency ¹	f_{FCLK}	150	—	200	kHz
D	Internal FCLK period (1/FCLK)	t_{FcyC}	5	—	6.67	μs
P	Byte program time (random location) ⁽²⁾	t_{prog}	9			t_{FcyC}
P	Byte program time (burst mode) ⁽²⁾	t_{Burst}	4			t_{FcyC}
P	Page erase time ²	t_{Page}	4000			t_{FcyC}
P	Mass erase time ⁽²⁾	t_{Mass}	20,000			t_{FcyC}
	Byte program current ³	R_{IDDBP}	—	4	—	mA
	Page erase current ³	R_{IDDPE}	—	6	—	mA
C	Program/erase endurance ⁴ T_L to $T_H = -40\text{ }^\circ\text{C}$ to $85\text{ }^\circ\text{C}$ $T = 25\text{ }^\circ\text{C}$		10,000	— 100,000	—	cycles
C	Data retention ⁵	$t_{\text{D_ret}}$	15	100	—	years

¹ The frequency of this clock is controlled by software setting.

² These values are hardware state machine controlled. User code does not need to count cycles. This information is supplied for calculating approximate time to program and erase.

³ The program and erase currents are additional to the standard run I_{DD} . These values are measured at room temperatures with $V_{DD} = 3.0\text{ V}$, bus frequency = 4.0 MHz.

⁴ **Typical endurance for flash** was evaluated for this product family on the 9S12Dx64. For additional information on how Freescale defines typical endurance, please refer to Engineering Bulletin EB619, *Typical Endurance for Nonvolatile Memory*.

⁵ **Typical data retention** values are based on intrinsic capability of the technology measured at high temperature and de-rated to 25°C using the Arrhenius equation. For additional information on how Freescale defines typical data retention, please refer to Engineering Bulletin EB618, *Typical Data Retention for Nonvolatile Memory*.

4 Ordering Information

This section contains ordering information for the MC9S08QE32 series of MCUs.

Example of the device numbering system:

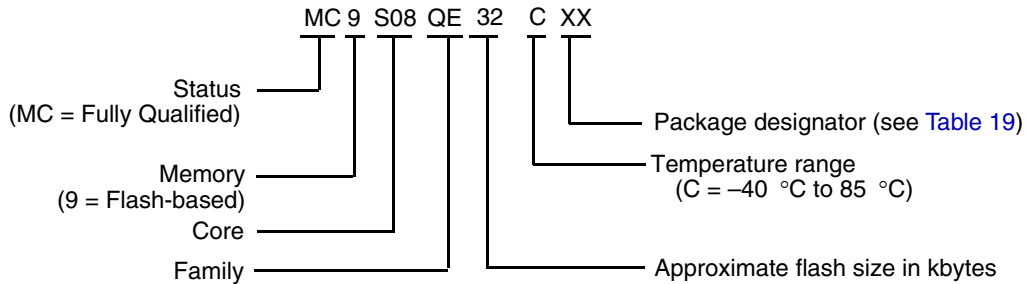

5 Package Information

Table 19. Package Descriptions

Pin Count	Package Type	Abbreviation	Designator	Case No.	Document No.
48	Quad Flat No-Leads	QFN	FT	1314	98ARH99048A
44	Low Quad Flat Package	LQFP	LD	824D	98ASS23225W
32	Low Quad Flat Package	LQFP	LC	873A	98ASH70029A
32	Quad Flat No-Leads	QFN	FM	1582	98ARE10566D
28	Small Outline Integrated Circuit	SOIC	WL	751F	98ASB42345B

5.1 Mechanical Drawings

The following pages are mechanical drawings for the packages described in Table 19. For the latest available drawings please visit our web site (<http://www.freescale.com>) and enter the package's document number into the keyword search box.

How to Reach Us:

Home Page:

www.freescale.com

Web Support:

<http://www.freescale.com/support>

USA/Europe or Locations Not Listed:

Freescale Semiconductor, Inc.
Technical Information Center, EL516
2100 East Elliot Road
Tempe, Arizona 85284
1-800-521-6274 or +1-480-768-2130
www.freescale.com/support

Europe, Middle East, and Africa:

Freescale Halbleiter Deutschland GmbH
Technical Information Center
Schatzbogen 7
81829 Muenchen, Germany
+44 1296 380 456 (English)
+46 8 52200080 (English)
+49 89 92103 559 (German)
+33 1 69 35 48 48 (French)
www.freescale.com/support

Japan:

Freescale Semiconductor Japan Ltd.
Headquarters
ARCO Tower 15F
1-8-1, Shimo-Meguro, Meguro-ku,
Tokyo 153-0064
Japan
0120 191014 or +81 3 5437 9125
support.japan@freescale.com

Asia/Pacific:

Freescale Semiconductor China Ltd.
Exchange Building 23F
No. 118 Jianguo Road
Chaoyang District
Beijing 100022
China
+86 10 5879 8000
support.asia@freescale.com

For Literature Requests Only:

Freescale Semiconductor Literature Distribution Center
P.O. Box 5405
Denver, Colorado 80217
1-800-441-2447 or +1-303-675-2140
Fax: +1-303-675-2150
LDCForFreescaleSemiconductor@hibbertgroup.com

Information in this document is provided solely to enable system and software implementers to use Freescale Semiconductor products. There are no express or implied copyright licenses granted hereunder to design or fabricate any integrated circuits or integrated circuits based on the information in this document.

Freescale Semiconductor reserves the right to make changes without further notice to any products herein. Freescale Semiconductor makes no warranty, representation or guarantee regarding the suitability of its products for any particular purpose, nor does Freescale Semiconductor assume any liability arising out of the application or use of any product or circuit, and specifically disclaims any and all liability, including without limitation consequential or incidental damages. "Typical" parameters that may be provided in Freescale Semiconductor data sheets and/or specifications can and do vary in different applications and actual performance may vary over time. All operating parameters, including "Typicals", must be validated for each customer application by customer's technical experts. Freescale Semiconductor does not convey any license under its patent rights nor the rights of others. Freescale Semiconductor products are not designed, intended, or authorized for use as components in systems intended for surgical implant into the body, or other applications intended to support or sustain life, or for any other application in which the failure of the Freescale Semiconductor product could create a situation where personal injury or death may occur. Should Buyer purchase or use Freescale Semiconductor products for any such unintended or unauthorized application, Buyer shall indemnify and hold Freescale Semiconductor and its officers, employees, subsidiaries, affiliates, and distributors harmless against all claims, costs, damages, and expenses, and reasonable attorney fees arising out of, directly or indirectly, any claim of personal injury or death associated with such unintended or unauthorized use, even if such claim alleges that Freescale Semiconductor was negligent regarding the design or manufacture of the part.



Freescale™ and the Freescale logo are trademarks of Freescale Semiconductor, Inc. All other product or service names are the property of their respective owners.

© Freescale Semiconductor, Inc. 2008-2011. All rights reserved.