

## Infrared Array Sensor Grid-EYE

PC Board Mounting

**AMG8854M01** (Narrow type)

High precision infrared array sensor based on advanced MEMS technology

### Feature

- Temperature detection of two-dimensional area: 8 × 8 (64 pixels)
- Digital output (capability of temperature value output)
- PC board mounting with connector (5 pin)
- RoHS compliance

### Recommended applications

- Home appliance (microwaves and air-conditioners)
- Energy saving at office (air conditioning control)
- Home automation (heat source detection)
- Factory automation (Fault prevention)

### Ordering information

<b>AMG</b>	<b>8</b>	<b>8</b>	<b>5</b>	<b>4M01</b>			
Code	Vertical pixel	Code	Horizontal pixel	Code	Applied voltage	Code	Product form
8	8 : 8 pixels	8	8 : 8 pixels	5	5.0 V	4M01	PC board mounting

### Types

Product name	Number of pixel	Operating voltage	Part number	Tape and reel package (pcs)
Infrared array sensor Grid-EYE Narrow angle type	64 (Vertical 8 × Horizontal 8 Matrix)	5.0 V	AMG8854M01	1000

### Rating

Item	Performance
Applied voltage	5.0 V ± 0.5 V
Temperature range of measuring object	-20 °C to 100 °C    -4 °F to +212 °F
Operating temperature range	-20 °C to 80 °C    -4 °F to +176 °F
Storage temperature range	-20 °C to 80 °C    -4 °F to +176 °F

### Absolute maximum ratings

Item	Absolute maximum ratings	Terminal
Applied voltage	-0.3 V to 6.5 V	VDD
Input voltage	-0.3 V to VDD +0.3 V	SCL, SDA, AD_SELECT
Output sink current	-10 mA to 10 mA	INT, SDA
Static electricity (Human body model)	1 kV	All terminals
Static electricity (Machine model)	200 V	All terminals

## Characteristics

Item	Performance
Temperature accuracy	Typ. $\pm 3.0\text{ }^{\circ}\text{C}$ $\pm 5.4\text{ }^{\circ}\text{F}$
Viewing angle	Typ. $35.6\text{ }^{\circ}$
Current consumption	Typ. 4.5 mA (normal mode) Typ. 0.2 mA (sleep mode)
Setup time	Typ. 50 ms (Time to enable communication after setup) 15 s or more (Time to stabilize output after setup)

## Performance

Item	Performance
Number of pixel	64 (Vertical 8 × Horizontal 8 Matrix)
External interface	I <sup>2</sup> C
Frame rate	Typ. 1 fps or Typ. 10 fps <sup>*1</sup>
Operating mode <sup>*2</sup>	Normal Sleep
Output mode	Temperature output
Calculate mode	No moving average or Twice moving average
Temperature output resolution	0.25 $^{\circ}\text{C}$ 0.45 $^{\circ}\text{F}$
Number of sensor address	1 (I <sup>2</sup> C slave address : 1101 000)
Thermistor output temperature range	-20 $^{\circ}\text{C}$ to 80 $^{\circ}\text{C}$ -4 $^{\circ}\text{F}$ to +176 $^{\circ}\text{F}$
Thermistor output resolution	0.0625 $^{\circ}\text{C}$ 0.1125 $^{\circ}\text{F}$

\*1: fps: frame per second

\*2: Normal Mode : normal operation mode

Sleep Mode: detection is off (output and data reading not possible)

## Internal circuit

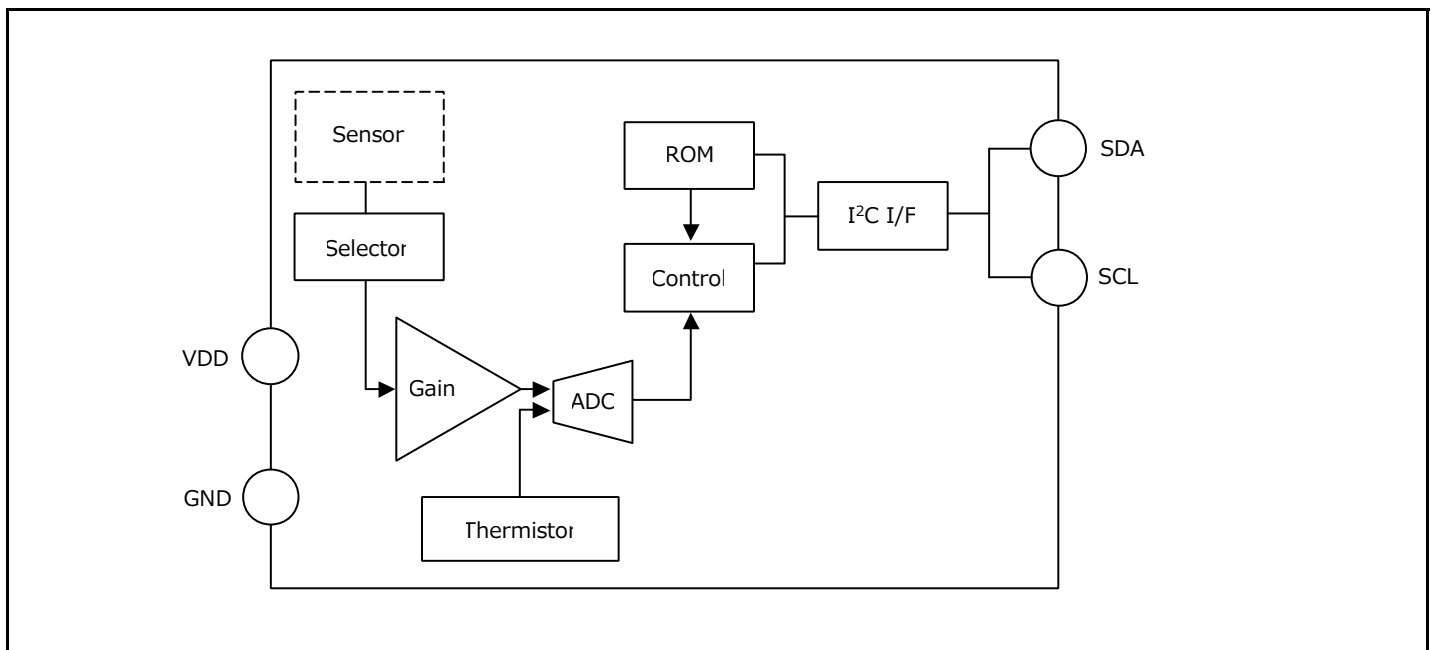

Print board circuit

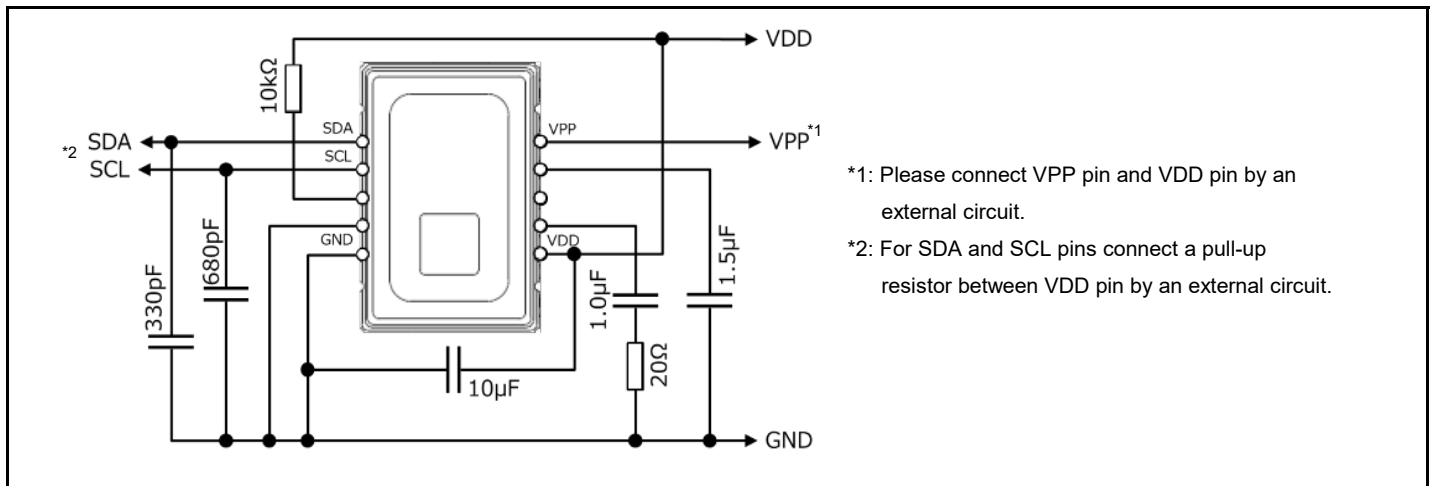

Pixel array and viewing angle

(1) Pixel array

Pixel array from 1 to 64 is shown below.

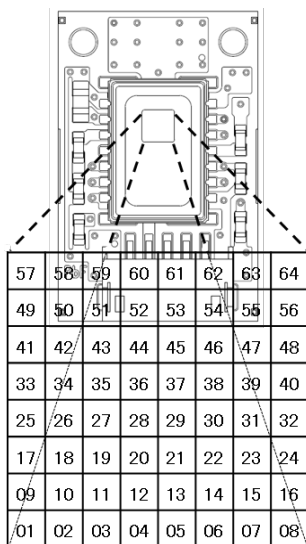

(2) Viewing field

Sensor viewing field (Typ.) is shown below.

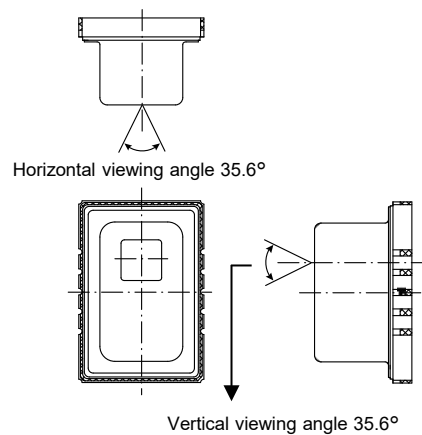

Optical properties

(1) Each pixel's viewing central angle

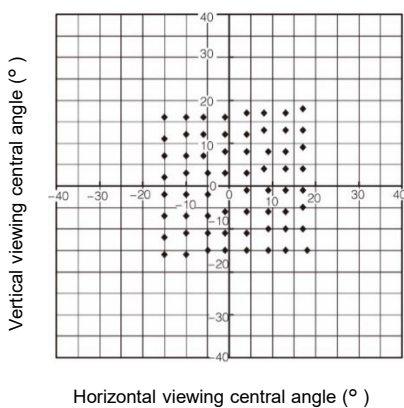

(2) Each pixel's viewing angle (half angle)

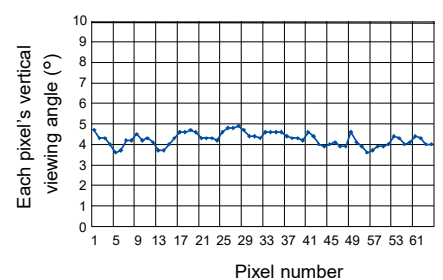
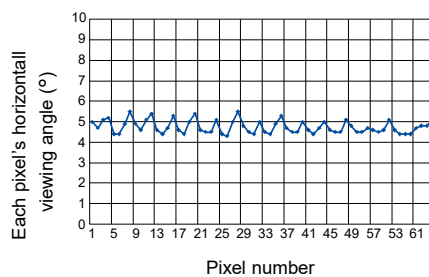

Dimensions

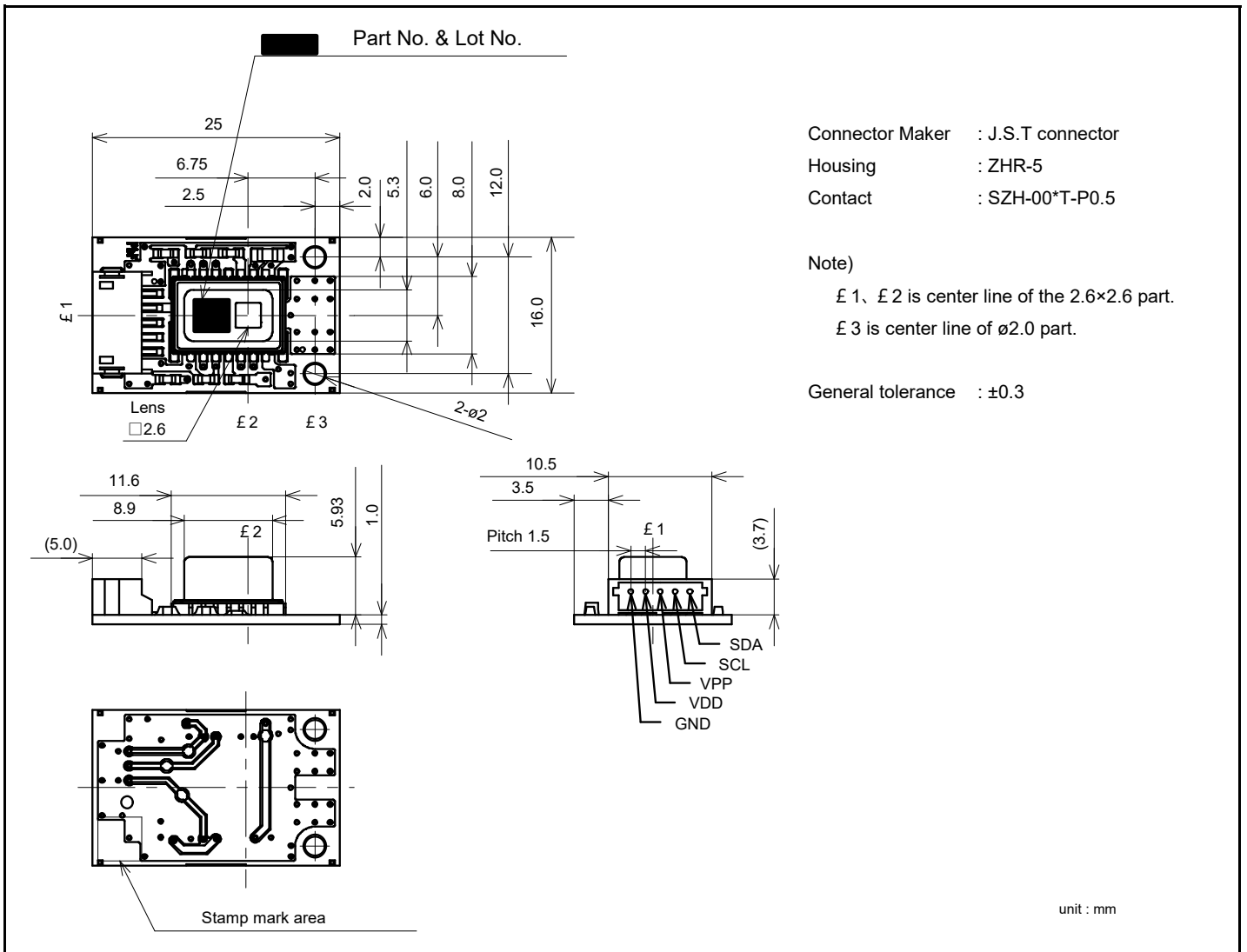

## Safety and Legal Matters to Be Observed

### Product specifications and applications

- Please be advised that this product and product specifications are subject to change without notice for improvement purposes. Therefore, please request and confirm the latest delivery specifications that explain the specifications in detail before the final design, or purchase or use of the product, regardless of the application. In addition, do not use this product in any way that deviates from the contents of the company's delivery specifications.
- Unless otherwise specified in this catalog or the delivery specifications, this product is intended for use in general electronic equipment (AV products, home appliances, commercial equipment, office equipment, information and communication equipment, etc.).  
When this product is used for the following special cases, please separately discuss the delivery specifications suited to each application with the company. These include applications requiring special quality and reliability, wherein their failures or malfunctions may directly threaten human life or cause harm to the human body (e.g.: space/aircraft equipment, transportation/traffic equipment, combustion equipment, medical equipment, disaster prevention/crime prevention equipment, safety equipment, etc.).

### Safety design and product evaluation

- Please ensure safety through protection circuits, redundant circuits, etc., in the customer's system design so that a defect in our company's product will not endanger human life or cause other serious damage.
- This catalog shows the quality and performance of individual parts. The durability of parts varies depending on the usage environment and conditions. Therefore, please ensure to evaluate and confirm the state of each part after it has been mounted in your product in the actual operating environment before use.  
If you have any doubts about the safety of this product, then please notify us immediately, and be sure to conduct a technical review including the above protection circuits and redundant circuits at your company.

### Laws / Regulations / Intellectual property

- The transportation of dangerous goods as designated by UN numbers, UN classifications, etc., does not apply to this product. In addition, when exporting products, product specifications, and technical information described in this catalog, please comply with the laws and regulations of the countries to which the products are exported, especially those concerning security export control.
- Each model of this product complies with the RoHS Directive (Restriction of the use of hazardous substances in electrical and electronic equipment) (2011/65/EU and (EU) 2015/863). The date of compliance with the RoHS Directive and REACH Regulation varies depending on the product model.  
Further, if you are using product models in stock and are not sure whether or not they comply with the RoHS Directive or REACH Regulation, please contact us by selecting "Sales Inquiry" from the inquiry form.
- During the manufacturing process of this product and any of its components and materials to be used, Panasonic does not intentionally use ozone-depleting substances stipulated in the Montreal Protocol and specific bromine-based flame retardants such as PBBs (Poly-Brominated Biphenyls) / PBDEs (Poly-Brominated Diphenyl Ethers). In addition, the materials used in this product are all listed as existing chemical substances based on the Act on the Regulation of Manufacture and Evaluation of Chemical Substances.
- With regard to the disposal of this product, please confirm the disposal method in each country and region where it is incorporated into your company's product and used.
- The technical information contained in this catalog is intended to show only typical operation and application circuit examples of this product. This catalog does not guarantee that such information does not infringe upon the intellectual property rights of Panasonic or any third party, nor imply that the license of such rights has been granted.

**Panasonic Industry will assume no liability whatsoever if the use of our company's products deviates from the contents of this catalog or does not comply with the precautions. Please be advised of these restrictions.**

## Matters to Be Observed When Using This Product

(Infrared array sensor / Grid-EYE : Narrow angle type)

### Use environments

- The product introduced here is a thermopile infrared sensor that detects the amount of infrared. In the cases described below, power output from the sensor may change. You need to be careful about the sensor behavior in such cases. Confirm the performance and reliability of the sensor in its actual service condition. If necessary, adjust the power output for the actual service condition.
  - (1) Case where the sensor shows a partial temperature change because of a heater (MCU, heat source, etc.) present near the sensor, hot air or cool air hitting the sensor, or the sensor is in contact with the housing of equipment.
  - (2) Case where an obstacle is present between the sensor and a target object, e.g., an obstacle that transmits miniscule infrared rays (glass, acrylic, steam, etc.) is present between the sensor and the target object or foreign matter that transmits miniscule infrared rays (dust, waterdrop, etc.) deposits on the lens of the sensor.
- The sensor is used or mounted in an environment where the rated performance of the sensor specified in the specifications is guaranteed. To know the working temperature of the sensor, refer to its rated values. Keep the humidity in the service environment at 15% RH to 85% RH and avoid dew concentration as well as freezing. Use the sensor under an atmospheric pressure ranging from 86 kPa to 106 kPa.
- Vibrations or impacts applied to the sensor can damage the sensor, causing an operation failure, performance drop, etc. Be careful in such cases. A lens damaged by a load or impact applied can also cause an operation failure, performance drop, etc. Be careful in such cases.
- The sensor is not waterproof nor dustproof. In the service environment where the sensor is to be used, you need to take measures against moisture, dust, dew concentration, and freezing. A waterdrop on a soldered part causes electromigration along the soldered part, thus causing a short circuit. Make the soldered part waterproof.
- Avoid using or storing the sensor in a place where corrosive gas (organic solvent gas, sulfur dioxide gas, hydrogen sulfide gas, etc.) is present near the sensor. Using or storing the sensor in such a place may lead to an operation failure or performance drop.
- If an external voltage surge is applied to the sensor, the internal circuit may be destroyed. Use a surge absorber, etc., to prevent such a case.
- The sensor may malfunction when exposed to static electricity, lightning, or electric noise from a cellular phone, radio transmitter, broadcasting station, etc.
- The working ambient temperature (humidity) range is a temperature (humidity) range in which the sensor can be operated continuously. The humidity range, however, varies depending on temperature. Observe the humidity ranges shown in the following graphs. Avoid using the sensor continuously in a temperature (humidity) condition close to the limit of the temperature (humidity) range. This temperature range does not guarantee the durability of the sensor.

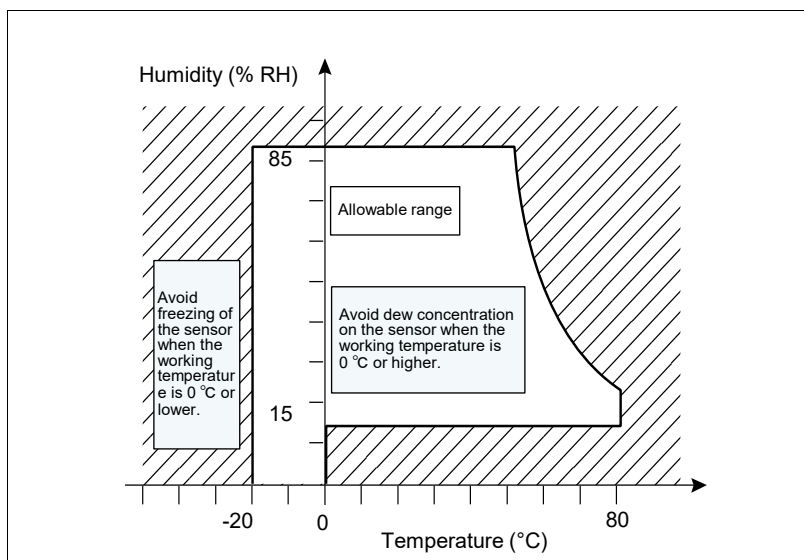

## Response to anomalies and handling conditions

- When the sensor is heating abnormally or emitting a smell, stop using the sensor immediately by, for example, turning off its power supply.
- Do not use a sensor disassembled or remodeled, a sensor removed from the board, or a sensor dropped on the floor. High-frequency vibrations applied to the sensor may put it out of order. Do not use the sensor where impact will be applied from coming in contact with a metal object or another sensor.
- The sensor may fail under the influence of static electricity. When handling the sensor, wear anti-static clothes and make sure to ground the human body, measurement instruments/jigs used, and equipment for setting up the sensor.
- When foreign matter, waterdrops, etc., deposits on the lens, wipe it off gently with a soft cloth. Wiping the lens with a strong force can peel the lens off or damage the lens surface, causing problems. Be careful when cleaning the lens surface. Avoid cleaning the sensor with ultrasonic waves. This cleaning method may cause wire breakage and lead to a failure of the sensor.

## Circuit design and circuit board design

- Confirm the pin arrangement by referring to specification drawings, etc., and connect leads correctly. Incorrect connection of the leads results in unexpected malfunctions, overheating, smoke generation, etc., which damage the circuit.
- Connect the sensor in accordance with the terminal connection diagram. Do not connect the sensor in reverse polarity to the power supply. It causes the sensor to fail or overheat. Make sure to connect a VPP node to a VDD node. Incorrect connection causes circuit failure.
- Adopt a printed board with a land wide enough to affix the sensor thereon. When mounting the sensor on a printed board that is not the one recommended for it, sufficiently check the performance and quality of the sensor before using it.

## Storage and transportation conditions

- Vibrations or impacts applied to the sensor during transportation may break the sensor. Handle the outer casing and reel carefully.
- Storing the sensor in an extremely unfavorable condition may result in a damaged appearance and degraded characteristics of the sensor. Store the sensor in a place where the temperature ranges from 0 °C to 45 °C, the humidity is 70% RH or lower, no sea breeze or corrosive gas (Cl<sub>2</sub>, H<sub>2</sub>S, NH<sub>3</sub>, SO<sub>2</sub>, NO<sub>x</sub>, etc.), little dust is present, and direct sunlight is blocked.
- Static electricity may destroy the sensor. Store and transport the sensor in an environment where no/little static electricity is generated (humidity 45% to 60%), and protect the sensor from static electricity by covering it with a conductive packaging material. When storing or transporting a sensor taken out of the package, put the sensor in an antistatic container.