

Description

The Si2162C integrates digital demodulators for all first and second generation DVB standards (DVB-T/T2/C/C2) in a single advanced CMOS die. Leveraging Skyworks' proven digital demodulation architecture, the Si2162C achieves excellent reception performance for each media while significantly minimizing front-end design complexity, cost, and power dissipation. Connecting the Si2162C to a hybrid TV tuner or digital only tuner, such as Skyworks' Si217x/5x/4x devices, results in a high-performance and cost optimized TV or STB front-end solution.

Skyworks' internally developed DVB-C2 demodulator can accept a standard IF (36 MHz) or low-IF input (differential) and support all modes specified by the DVB-C2 standard. The main features of the DVB-C2 mode are 4096-QAM, 6 or 8 MHz bandwidth, management of notch insertion (broadband and narrowband), and support of multiple data slices and PLPs.

DVB-T2/T and DVB-C2/C demodulators are next-generation enhanced versions of proven and broadly-used Skyworks' Si2169/68/67/66/64/62/60 devices. DVB-T2-Lite (ETSI EN 302 755-V1.3.1) compatibility is also supported.

The cable reception allows demodulating widely deployed DVB-C legacy standard (ITU-T J.83 Annex A/C) and the Americas' cable standard (ITU-T J.83 Annex B).

The Si2162C offers an on-chip blind scan algorithm for DVB-C/C2 standards, as well as a blind lock function. The Si2162C programmable transport stream output interface provides a flexible range of output modes and is fully compatible with all MPEG decoders or conditional access modules to support any customer application.

Features

- Pin-to-pin compatible with all Si216x/8x single demods family
- API compatible with all single and dual demods families
- DVB-T2 (ETSI EN 302 755-V1.4.1) with T2-Lite (Annex I)
 - Bandwidth: 1.7, 5, 6, 7, and 8 MHz
 - NorDig Unified 2.5 and D-Book 8 compliant
- DVB-C2 (ETSI EN 302 769)
 - 16-QAM to 4096-QAM OFDM demodulation
- DVB-T (ETSI EN 300 744)
 - OFDM demodulator and enhanced FEC decoder
 - NorDig Unified 2.5 and D-Book 8 compliant
- DVB-C (ETSI EN 300 429) and ITU-T J.83 Annex A/B/C
 - QAM demodulator and FEC decoder
 - 1 to 7.2 MSymbol/s
- LDPC and BCH FEC decoding for C2/T2 standards
- I²C serial bus interfaces (master and host)
- Firmware control (embedded ROM/NVM)
- Upgradeable with patch download via fast SPI or I²C (broadcast mode supported)
- Flexible TS output interface (serial, parallel, and slave)
- Fast lock times for all media
- Low power consumption
- Two power supplies: 1.2 and 3.3 V
- 7x7 mm, QFN-48 pin package, Pb-free/RoHS compliant

Applications

- iDTV: on-board design or in a NIM
- Advanced multimedia STB, PVR, and Blu-ray recorders
- PC-TV accessories

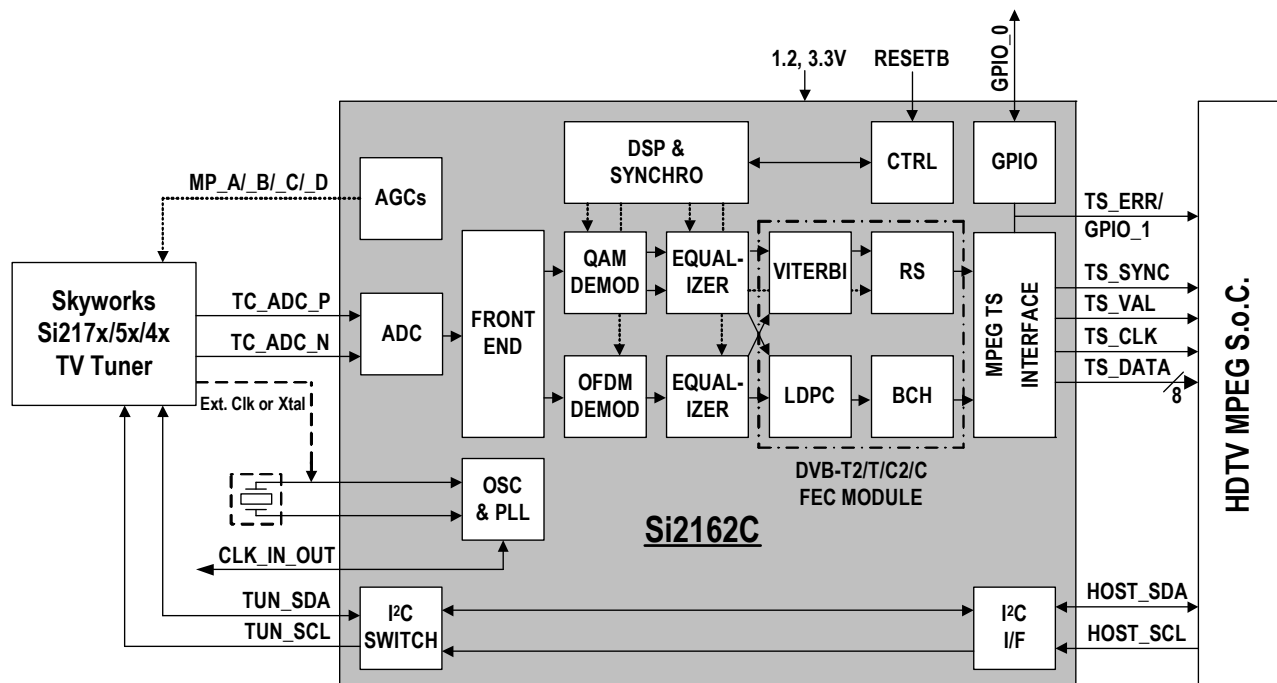

Selected Electrical Specifications

(T_A = -10 to 75 °C)

Parameter	Test Condition	Min	Typ	Max	Unit
General					
Input clock reference		4	—	30	MHz
Supported XTAL frequency		16	—	30	MHz
Total power consumption	DVB-T2 ¹	—	356	—	mW
	DVB-T ²	—	182	—	mW
	DVB-C2 ³	—	327	—	mW
	DVB-C ⁴	—	142	—	mW
Thermal resistance	2 layer PCB	—	35	—	°C/W
	4 layer PCB	—	23	—	°C/W
Power Supplies					
V _{DD_VCORE}		1.14	1.20	1.30	V
V _{DD_VANA}		3.00	3.30	3.60	V
V _{DD_VIO}		3.00	3.30	3.60	V
Notes:					
1. Test conditions: 8 MHz, 256-QAM, 32K FFT, CR = 3/5, GI = 1/128, PP7, parallel TS, C/N at picture failure.					
2. Test conditions: 8 MHz, 8K FFT, 64-QAM, parallel TS.					
3. Test conditions: 4096-QAM, CR = 5/6, GI = 1/128, C/N = 34 dB (at picture failure).					
4. Test conditions: 6.9 Mbaud, 256-QAM, parallel TS.					

Pin Assignments

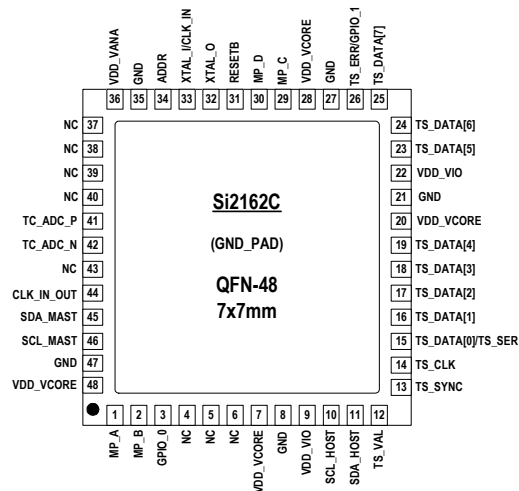

Selection Guide

Part Number	Description
Si2162-C60-GM	DVB-T2/C2/T/C Digital TV demodulator, 7x7 mm QFN-48