

HERMAPHRODITIC PUSH-PULL CONNECTORS

 SERIES

4.21 mm

4.295 mm

4.38 mm

4.65 mm

4.8 mm

B7

B8

B9

240

Frequency / GHz

245

250

 **LEMO**[®]

Precision modular connectors to suit your application

Since its creation in Switzerland in 1946 the LEMO Group has been recognized as a global leader of circular Push-Pull connectors and connector solutions. Today LEMO and its affiliated companies, REDEL and COELVER, are active in more than 80 countries with the help of over 40 subsidiaries and distributors.

Over 50'000 connectors

The modular design of the LEMO range provides over 50'000 connectors from miniature \varnothing 3 mm to \varnothing 50 mm, capable of handling cable diameters up to 30 mm and for up to 106 contacts.

This vast portfolio enables you to select the ideal connector configuration to suit almost any specific requirement in most markets, including medical devices, test and measurement instruments, machinery, audio video broadcast, telecommunications and military.

LEMO's Push-Pull Self-Latching Connection System

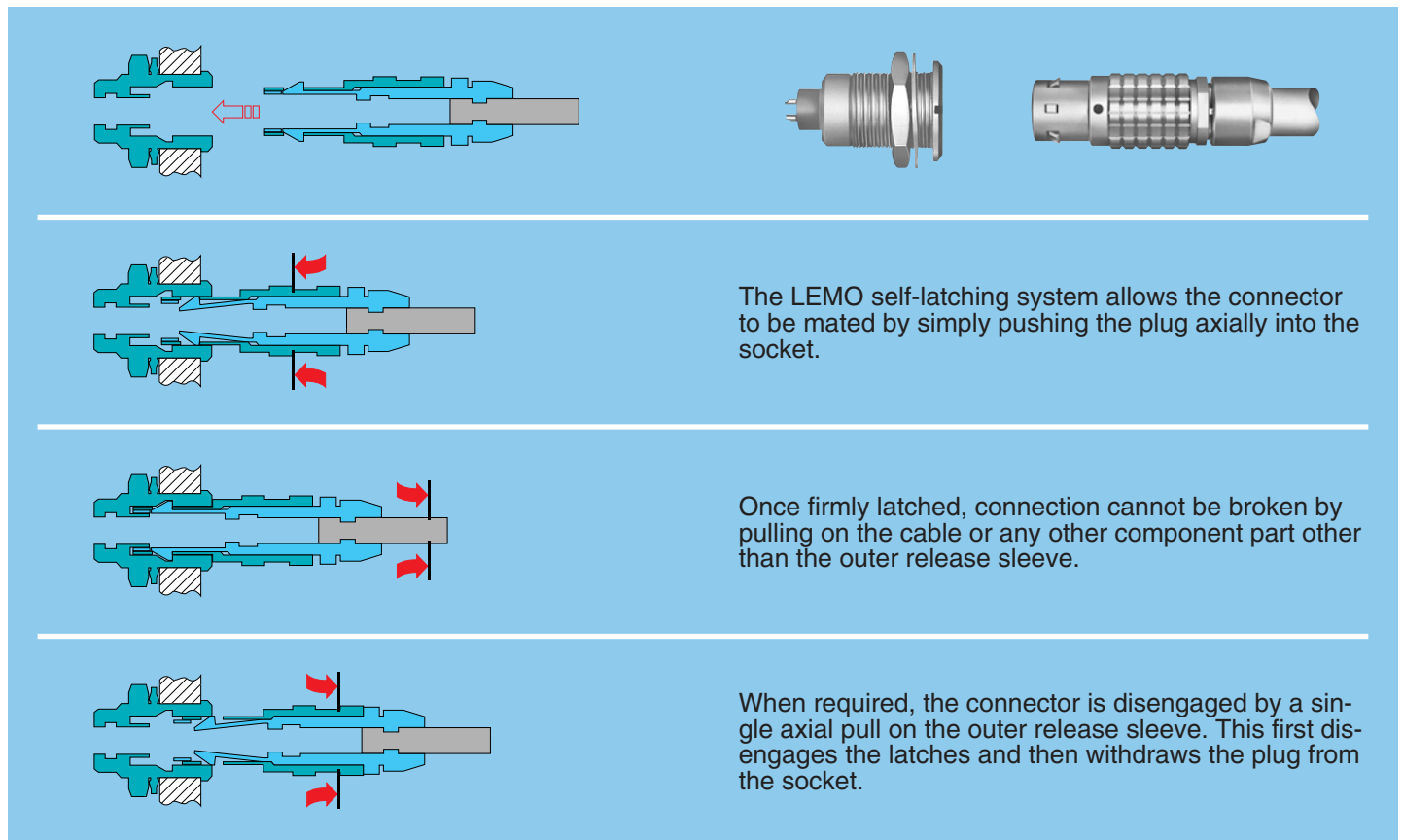

This self-latching system is renowned worldwide for its easy and quick mating and unmating features. It provides absolute security against vibration, shock or pull on the cable, and facilitates operation in a very limited space.



UL Recognition

LEMO connectors are recognized by the Underwriters Laboratories (UL). The approval of the complete system (LEMO connector, cable and your equipment) will be easier because LEMO connectors are approved.

CE marking

CE marking  means that the appliance or equipment bearing it complies with the protection requirements of one or several European safety directives. CE marking  applies to complete products or equipment, **but not to electromechanical components, such as connectors.**

RoHS

LEMO connectors are in compliance with the RoHS directives (2002/95/EC) of the European Parliament. This directive specifies the restrictions of the use of hazardous substances in electrical and electronic equipment marketed in Europe. LEMO guarantees that its connectors are free of mercury, cadmium, lead, hexavalent chromium and polybromide biphenyl (PBB) or polybromide diphenyl ether (PBDE).

SH-MH Series

The LEMO Hermaphroditic series provide a rugged high performance patented push-pull hermaphroditic interconnection system. These «genderless» connectors combine LEMO's well proven push-pull latching technology and the use of our standard high quality optical and electrical contacts.

The main features of these series are as follow:

- security of a new patented push-pull hermaphroditic self-latching system
- 2 shell sizes, SH and MH series
- compact unsealed version for general purpose applications
- rugged waterproof (IP 68) version for all outdoor applications
- a choice of multifibre or electrical contacts configurations
- lightweight design with shell in anthracite nickel-plated aluminium alloy
- low loss ceramic PC technology in multimode and singlemode
- gold plated electrical contacts.

Each series consists of plug and socket which will accept cable diameter ranging from 3.6 mm to 10 mm. Initial program is giving solutions with 2, 4 or 6 fibre optic channel and 6 or 12 electrical contacts.

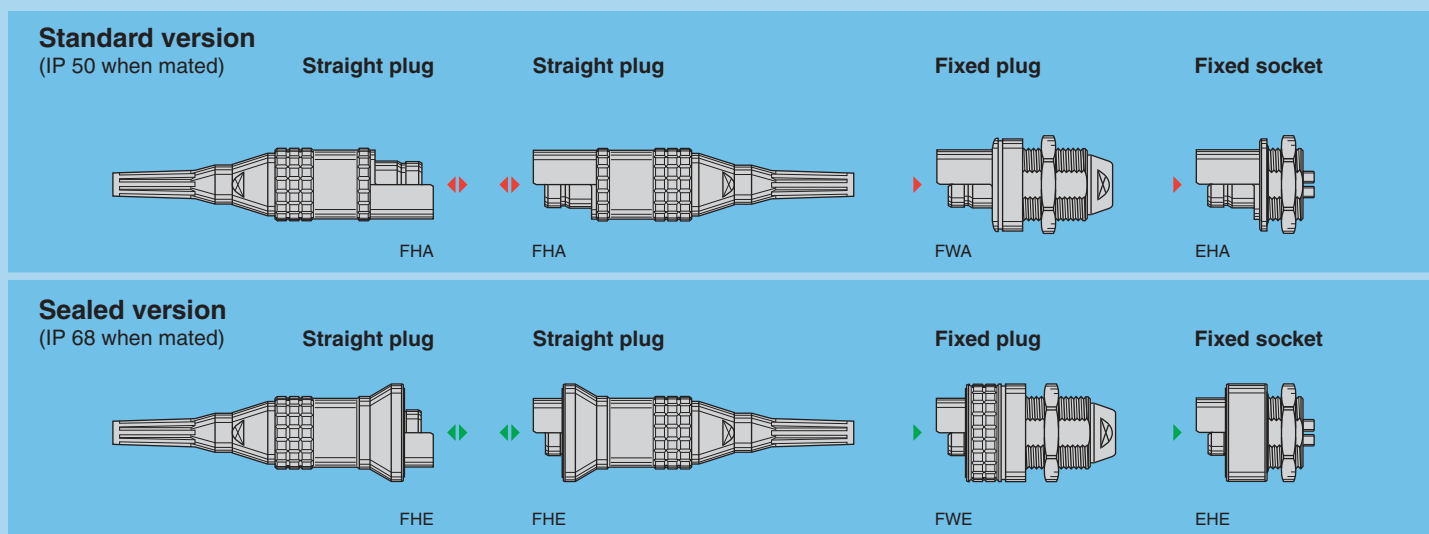

Part Section Showing Internal Components

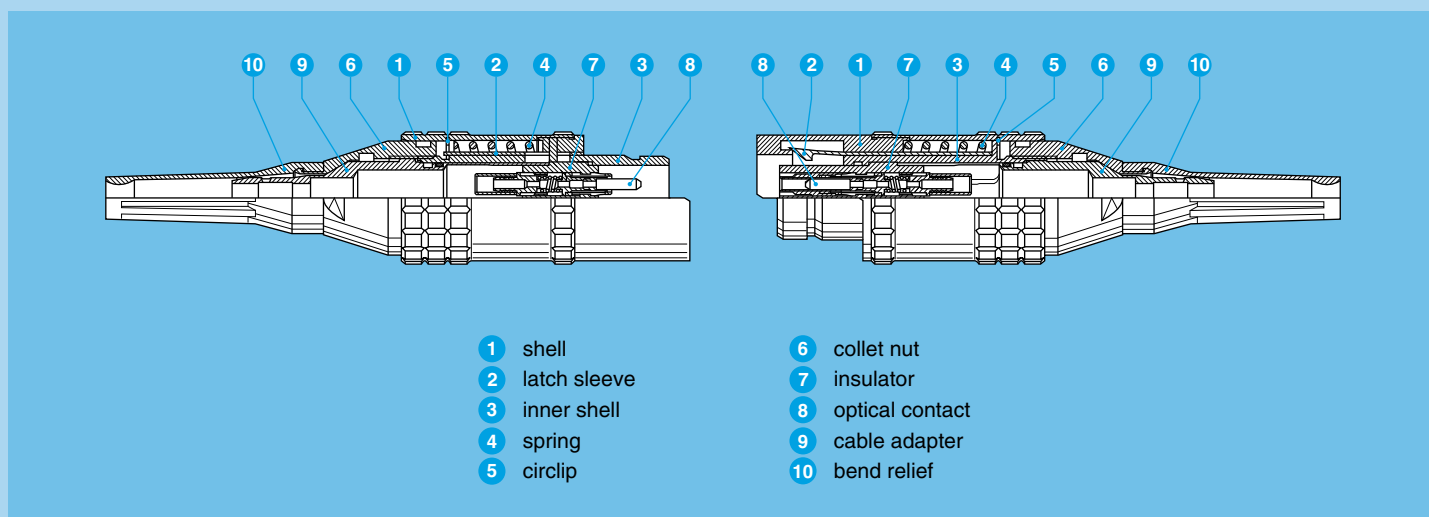

Technical Characteristics

Mechanical and Environmental

Characteristic	Value	Standard
Mating durability	2000 cycles	IEC 60512-5 test 9a
Temperature range	-55°C to +125°C ¹⁾	
Vibration resistance	10-2000 Hz, 15g	IEC 60512-4 test 6d
Shock resistance	100 g, 6 ms	IEC 60512-4 test 6c
Protection index FHE/FHE	IP 68	IEC 60529
Water immersion FHE/FHE	up to 2 meters depth	
Protection index FHA/FHA	IP 50	IEC 60529
Average latching retention	SH series plug/plug	IEC 60512-8 test 15f
	SH series plug/socket	
	MH series plug/plug	
	MH series plug/socket	

Electrical

Characteristic	Value	Standard
Insulation resistance	> 10 ¹² Ω	IEC 60512-2 test 3a
Contact resistance	< 3.6 mΩ	IEC 60512-2 test 11f
Shell resistance	< 10 mΩ	IEC 60512-2 test 2f

Notes: 1) with f.o. contacts temperature range -40°C/+80°C

Optical

Characteristic	Value	Standard	Method
Average insertion loss fibre 9/125 µm	0.18 dB	IEC 61300-03-34	Method 2
Average insertion loss fibre 50/125 µm	0.25 dB	IEC 61300-03-34	Method 2
Return loss fibre 9/125 µm (UPC)	≥45 dB	IEC 61300-03-06	Coupler Method
Return loss fibre 9/125 µm (Hand polish)	>25 dB	IEC 61300-03-06	Coupler Method

Materials and Treatments

Component	Material (Standard)	Surface treat (µm)		
		nickel		
		Cu	Ni	Au
Outer shell, collet nut ¹⁾	Alum. (AA 6262A or AA 6023)	–	5	–
Latch sleeve	Special brass	0.5	3	–
Other metallic parts	Alum. (AA 6262A or AA 6023)	–	5	–
Spring	Stainless steel	without treatment		
Insulator	PEEK	without treatment		
Electrical contacts	Brass (male)/Bronze (female)	0.5	3	1
O-ring and gaskets	Silicone MQ / MVQ	without treatment		

Notes: 1) anthracite colour

Part Number Example

A different part number structure is applicable for each of the following product types:

– Plugs and fixed sockets; fibre optic contacts.

Note: The fibre optic contacts must be ordered separately. An equal number of contacts must be ordered (eg. for MH.03C; 2 x FFS.F2 and 2 x PSS.F2).

Straight plug with bend relief

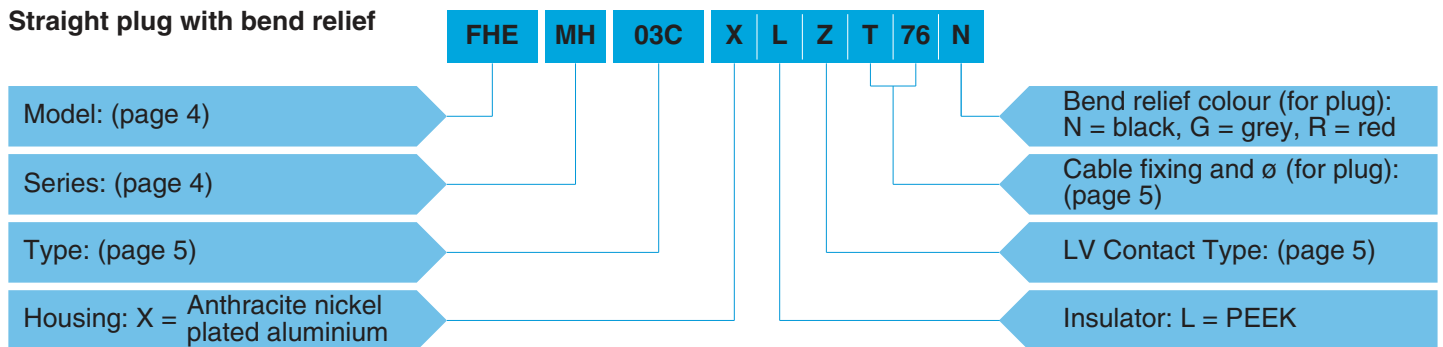

FHE.MH.03C.XLZT76N = Straight plug (IP 68 when mated), MH series, multifibre to accept 4 F2 type fibre optic contacts, anthracite nickel plated aluminium shell, PEEK insulator, with cable fixing type T for 7.5 to 6.6 mm cable and black bend relief.

Fiber optic contact

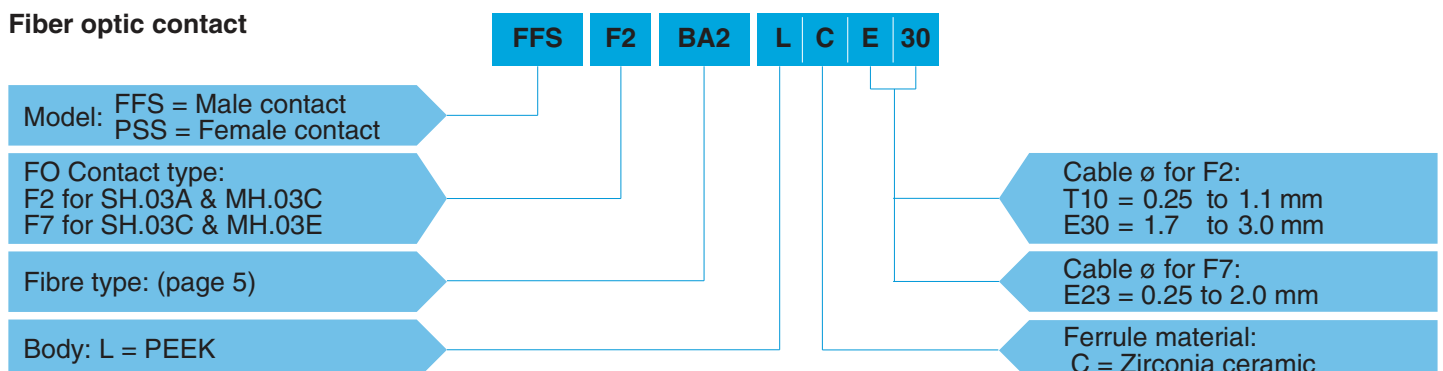

FFS.F2.BA2.LCE30 = Male F2 type fibre optic contact, ferrule bore diameter of 125 µm, PEEK body, Zirconia ceramic ferrule, crimp cable fixing, for tight jacket cable with a diameter between 1.7 to 3.0 mm.

Models - Series



FHA Straight plug with cable adapter or collet and nut with bend relief

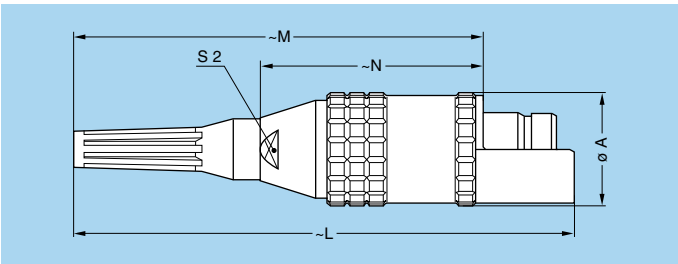

Reference		Dimensions (mm)				
Model	Series	A	L	M	N	S2
FHA	SH	21.8	98.4	82.2	46.2	13
FHA	MH	25.4	109.3	89.1	47.1	15



FWA Fixed plug, nut fixing

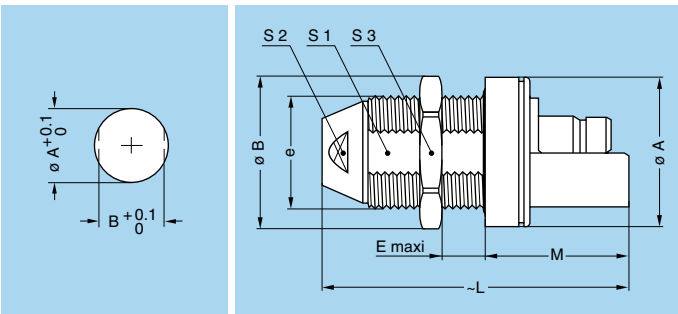

Reference		Dimensions (mm)								
Model	Series	A	B	e	E	L	M	S1	S2	S3
FWA	SH	28.5	28.5	M22x1	14	55.0	26.5	20.5	14	25
FWA	MH	34.0	34.0	M25x1	17	64.5	31.5	23.5	17	30

Panel cut-outs	Series	Dim. (mm)	
		ø A	B
	SH	22.2	20.6
	MH	25.2	23.6



EHA Fixed socket, nut fixing

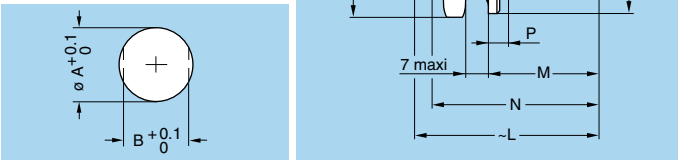

Reference		Dimensions (mm)									
Model	Series	A	B	e	L		M	N	P	S1	S3
					opt.	elect.					
EHA	SH	27	28.5	M22x1	38.8	30.5	19.5	30.5	3.3	20.5	25
EHA	MH	32	34.0	M25x1	40.8	37.0	24.5	37.0	4.3	23.5	30

Panel cut-outs	Series	Dim. (mm)	
		ø A	B
	SH	22.2	20.6
	MH	25.2	23.6

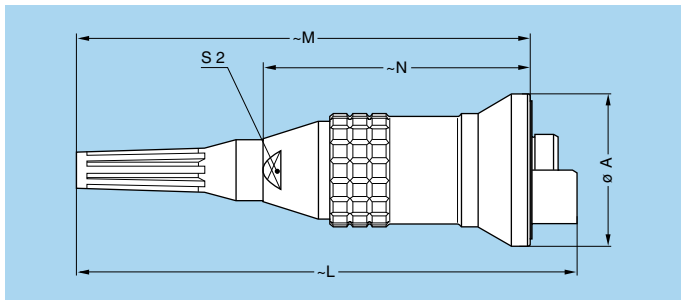

FHE Straight plug with cable adapter or collet and nut with bend relief (IP 68 when mated)

Reference		Dimensions (mm)				
Model	Series	A	L	M	N	S2
FHE	SH	28.5	98.4	90.0	54.0	13
FHE	MH	34.0	109.3	98.9	56.9	15

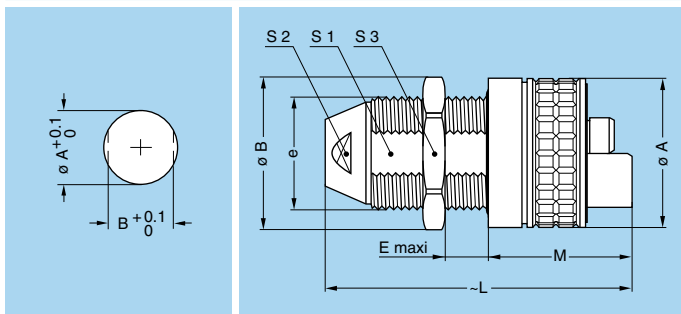

FWE Fixed plug, nut fixing (IP 68 when mated)

Reference		Dimensions (mm)								
Model	Series	A	B	e	E	L	M	S1	S2	S3
FWE	SH	28.5	28.5	M22x1	14	55.0	26.5	20.5	14	25
FWE	MH	34.0	34.0	M25x1	17	64.5	31.5	23.5	17	30

Panel cut-outs

Series	Dim. (mm)	
	ø A	B
SH	22.2	20.6
MH	25.2	23.6

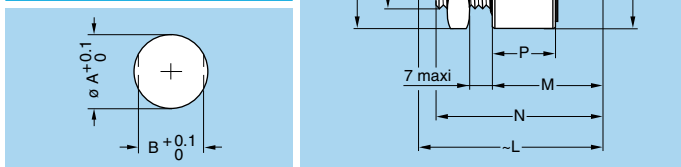

EHE Fixed socket, nut fixing (IP 68 when mated)

Reference		Dimensions (mm)									
Model	Series	A	B	e	L		M	N	P	S1	S3
					optic	elect.					
EHE	SH	28.5	28.5	M22x1	38.8	30.5	19.5	30.5	11.1	20.5	25
EHE	MH	34.0	34.0	M25x1	40.8	37.0	24.5	37.0	14.1	23.5	30

Panel cut-outs

Series	Dim. (mm)	
	ø A	B
SH	22.2	20.6
MH	25.2	23.6

Insert configuration

	Plug	Socket	Reference	FO contact		Low Voltage contact						
				F2 Nb	F7 Nb	Contact Nb	ø A (mm)	Contact type		Test voltage (kV rms)	Test voltage (kV dc)	Rated current (A)
								AWG max	AWG			
								Solder	Crimp			
SH			03A	2	-	-	-	-	-	-	-	-
			03C	-	4	-	-	-	-	-	-	-
			306	-	-	6	1.3	20	18-20	1.5	2.1	12
MH			03C	4	-	-	-	-	-	-	-	-
			03E	-	6	-	-	-	-	-	-	-
			312	-	-	12	1.3	20	18-20	1.0	1.5	8

Note: Other arrangement, optical, electrical or mixed optical-electrical can be made available upon request.
WARNING: There is no contact number on the insulator. When wiring one hermaphroditic connector, one should terminate each contact to its mirror image number of the other connector.

Electrical contact

Reference	Contact type	Reference	Contact type
A	solder for plug	M	crimp for socket
C	crimp for plug	Z	no contact
L	solder for socket		

Fibre type

Reference for F2 contact	Reference for F7 contact	ø Core/Cladding (µm)	Ferrule hole ø (µm)	Note
BA2	125	9/125	125	●
BB2	126	50/125	126	●
BD2	128	62.5/125	128	○

● First choice alternative ○ Special order alternative

Cable diameter

	Adapter «T» for fibre optic connectors		Collet «C» for electrical connectors			
	Ref.	Cable ø	Ref.	Cable ø		
		max	min	max	min	
SH	T46	4.5	3.6	C52	5.0	4.1
	T56	5.5	4.6	C62	6.0	5.1
	T66	6.5	5.6	C72	7.0	6.1
	T76	7.5	6.6	C82	8.0	7.1
MH	T56	5.5	4.6	C62	6.0	5.1
	T66	6.5	5.6	C72	7.0	6.1
	T76	7.5	6.6	C82	8.0	7.1
	T86	8.5	7.6	C92	9.0	8.1
	T91	9.0	8.6	C10	10.0	9.1

Accessories

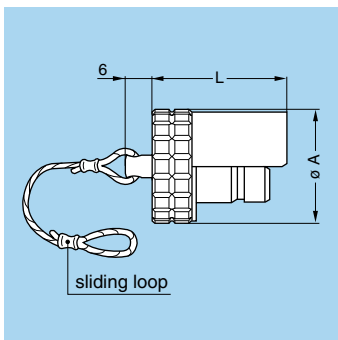

BFA Cap (for FHA and FWA plugs)

Part number	Dim. (mm)	
	A	L
BFA.SH.100.XAZ	21.8	23.5
BFA.MH.100.XAZ	25.4	30.0

- Body material: Anthracite nickel plated aluminium alloy
- Lanyard material: Stainless steel
- Crimp ferrule material: Nickel-plated brass + polyolefin
- Maximum operating temperature: 125°C
- Watertightness: IP50 according to IEC 60529

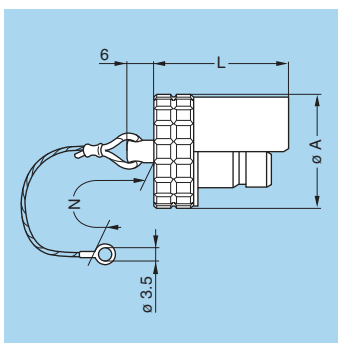

BHA Cap (for FHA and FWA plugs)

Part number	Dim. (mm)		
	A	L	N
BHA.SH.100.XAZ	21.8	23.5	120
BHA.MH.100.XAZ	25.4	30.0	120

- Body material: Anthracite nickel plated aluminium alloy
- Lanyard material: Stainless steel
- Crimp ferrule material: Nickel-plated brass + polyolefin
- Maximum operating temperature: 125°C
- Watertightness: IP50 according to IEC 60529

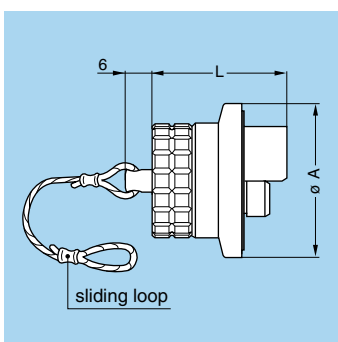

BFE Cap (for FHE and FWE plugs)

Part number	Dim. (mm)	
	A	L
BFE.SH.100.XAS	28.5	23.5
BFE.MH.100.XAS	34.0	30.0

- Body material: Anthracite nickel plated aluminium alloy
- Lanyard material: Stainless steel
- Crimp ferrule material: Nickel-plated brass + polyolefin
- O-ring material: Silicone rubber
- Maximum operating temperature: 125°C
- Watertightness: IP68 according to IEC 60529

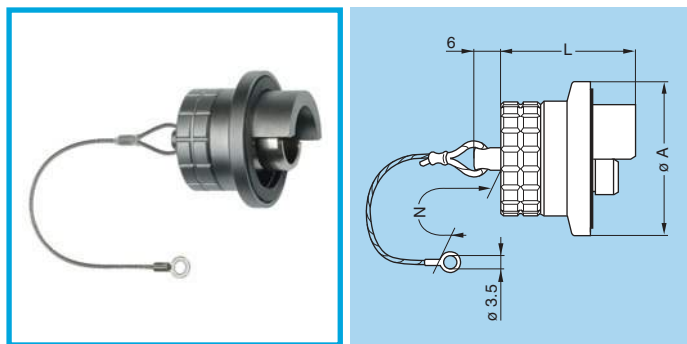

BHE Cap (for FHE and FWE plugs)

Part number	Dim. (mm)		
	A	L	N
BHE.SH.100.XAS	28.5	23.5	120
BHE.MH.100.XAS	34.0	30.0	120

- Body material: Anthracite nickel plated aluminium alloy
- Lanyard material: Stainless steel
- Crimp ferrule material: Nickel-plated brass + polyolefin
- O-ring material: Silicone rubber
- Maximum operating temperature: 125°C
- Watertightness: IP68 according to IEC 60529

Tooling

WST.KI.125.34 Cleaning kit for F2 fibre optic contact



Description

Fibre optic cleaning kit of 2 cotton buds, 1 dry and 1 being soaked in IPA (Isopropyl Alcohol) used for cleaning the fibre optic contacts.

DCC.91.312.5LA Extraction/Installation tool for F2 fibre optic contact

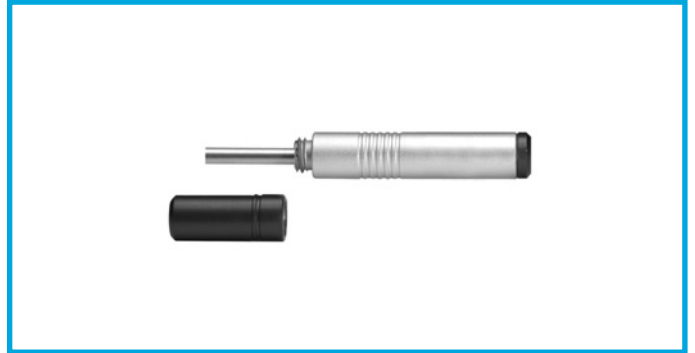

DCS Contact alignment device tool for F2 or F7 fibre optic contact

Description

Simple tool with two threaded end for installation/extraction of the F7 contact alignment device.

Part number	Contact type
DCS.F2.035.PN	F2
DCS.F7.035.PN ¹⁾	F7

Note: ¹⁾ Included in the LEMO F7 workstation.

DCC Extractor for F7 fibre optic contact

Description

Manual tool for the extraction of the F7 contact.

Part number
DCC.91.307.5LA ¹⁾

Note: ¹⁾ Included in the LEMO F7 workstation.

Product safety notice

PLEASE READ AND FOLLOW ALL INSTRUCTIONS CAREFULLY AND CONSULT ALL RELEVANT NATIONAL AND INTERNATIONAL SAFETY REGULATIONS FOR YOUR APPLICATION. IMPROPER HANDLING, CABLE ASSEMBLY, OR WRONG USE OF CONNECTORS CAN RESULT IN HAZARDOUS SITUATIONS.

1. SHOCK AND FIRE HAZARD

Incorrect wiring, the use of damaged components, presence of foreign objects (such as metal debris), and / or residue (such as cleaning fluids), can result in short circuits, overheating, and / or risk of electric shock. Mated components should never be disconnected while live as this may result in an exposed electric arc and local overheating, resulting in possible damage to components.

2. HANDLING

Connectors and their components should be visually inspected for damage prior to installation and assembly. Suspect components should be rejected or returned to the factory for verification. Connector assembly and installation should only be carried out by properly trained personnel. Proper tools must be used during installation and / or assembly in order to obtain safe and reliable performance.

3. USE

Connectors with exposed contacts should never be live (or on the current supply side of a circuit). Under general conditions voltages above 30 VAC and 42 VDC are considered hazardous and proper measures should be taken to eliminate all risk of transmission of such voltages to any exposed metal part of the connector.

4. TEST AND OPERATING VOLTAGES

The maximum admissible operating voltage depends upon the national or international standards in force for the application in question. Air and creepage distances impact the operating voltage; reference values are indicated in the catalog however these may be influenced by PC board design and / or wiring harnesses. The test voltage indicated in the catalog is 75% of the mean breakdown voltage; the test is applied at 500 V/s and the test duration is 1 minute.

5. CE MARKING

CE Marking is applied to a complete product or device, and implies that the device complies with one or several European safety directives. CE Marking can not be applied to electromechanical components such as connectors.

6. PRODUCT IMPROVEMENTS

The LEMO Group reserves the right to modify and improve to our products or specifications without providing prior notification.

LEMO HEADQUARTERS

SWITZERLAND

LEMO SA

Chemin des Champs-Courbes 28 - P.O. Box 194 - CH-1024 Ecublens
Tel. (+41 21) 695 16 00 - Fax (+41 21) 695 16 02 - e-mail: info@lemo.com

LEMO SUBSIDIARIES

AUSTRIA

LEMO Elektronik GesmbH

Lemböckgasse 49/E6-3
1230 Wien
Tel: (+43 1) 914 23 20 0
Fax: (+43 1) 914 23 20 11
sales@lemo.at

CHINA

LEMO Trading (Shanghai) Co., Ltd

LEMO Electronics (Shanghai) Co., Ltd

5th Floor, Block 6, City of ELITE,
1000 Jinhai Road, Pudong
Shanghai, China 201206
Tel: (+86 21) 5899 7721
Fax: (+86 21) 5899 7727
cn.sales@lemo.com

DENMARK

LEMO Denmark A/S

Gammel Mosevej 46
2820 Gentofte
Tel: (+45) 45 20 44 00
Fax: (+45) 45 20 44 01
info-dk@lemo.com

FRANCE

LEMO France Sàrl

24/28 Avenue Graham Bell
Bâtiment Balthus 4
Bussy Saint Georges
77607 Marne la Vallée Cedex 3
Tel: (+33 1) 60 94 60 94
Fax: (+33 1) 60 94 60 90
info-fr@lemo.com

GERMANY

LEMO Elektronik GmbH

Hanns-Schwindt-Str. 6
81829 München
Tel: (+49 89) 42 77 03
Fax: (+49 89) 420 21 92
info@lemo.de

HONG KONG

LEMO Hong Kong Ltd

Unit 1207, 12/F, Corporation Square,
8 Lam Lok Street, Kowloon Bay,
Kowloon - Hong Kong
Tel: (+852) 2174 0468
Fax: (+852) 2174 0492
hk.sales@lemo.com

HUNGARY

REDEL Elektronika Kft

Nagysándor József u. 6-12
1201 Budapest
Tel: (+36 1) 421 47 10
Fax: (+36 1) 421 47 57
redelemo@lemo.hu

ITALY

LEMO Italia srl

Viale Lunigiana 25
20125 Milano
Tel: (+39 02) 66 71 10 46
Fax: (+39 02) 66 71 10 66
sales.it@lemo.com

JAPAN

LEMO Japan Ltd

4-10-3, Takaido Higashi,
Suginami-ku, Tokyo, 168-0072
Tel: (+81 3) 53 44 39 33
Fax: (+81 3) 53 44 39 35
lemoinfo@lemo.co.jp

NETHERLANDS / BELGIUM

LEMO Connectors Benelux

De Trompet 2108
1967 DC Heemskerk
Tel. (+31) 251 25 78 20
Fax (+31) 251 25 78 21
info@lemo.nl

NORWAY / ICELAND

LEMO Norway A/S

Stanseveien 6B
0975 Oslo
Tel: (+47) 22 91 70 40
Fax: (+47) 22 91 70 41
info-no@lemo.com

SINGAPORE

LEMO Asia Pte Ltd

4 Leng Kee Road,
#06-09 SiS Building
Singapore 159088
Tel: (+65) 6476 0672
Fax: (+65) 6474 0672
sg.sales@lemo.com

SPAIN / PORTUGAL

IBERLEMO S.A.

Brasil, 45, 08402 Granollers
Barcelona
Tel: (+34 93) 860 44 20
Fax: (+34 93) 879 10 77
info-es@lemo.com

Madrid Office
Antonio López, 96, 28019 Madrid
Tel: (+34 91) 469 99 19
Fax: (+34 91) 469 99 59

SWEDEN / FINLAND

LEMO Nordic AB

Mariehällsvägen 39A
168 65 Bromma
Tel: (+46 8) 635 60 60
Fax: (+46 8) 635 60 61
info-se@lemo.com

SWITZERLAND

LEMO Verkauf AG

Grundstrasse 22 B
6343 Rotkreuz
Tel: (+41 41) 790 49 40
Fax: (+41 41) 790 49 43
ch.sales@lemo.com

UNITED KINGDOM

LEMO UK Ltd

12-20 North Street
Worthing
West Sussex, BN11 1DU
Tel: (+44 1903) 23 45 43
Fax: (+44 1903) 20 62 31
lemouk@lemo.com

USA

LEMO USA Inc

P.O. Box 2408
Rohnert Park, CA 94927-2408
Tel: (+1 707) 578 88 11
(+1 800) 444 53 66
Fax: (+1 707) 578 08 69
info@lemousa.com

LEMO DISTRIBUTORS

AUSTRALIA, BRAZIL, CANADA, CZECH REPUBLIC, GREECE, INDIA, ISRAEL,
NEW ZEALAND, PAKISTAN, POLAND, RUSSIA, SOUTH AFRICA, SOUTH KOREA,
TAIWAN, TURKEY, UKRAINE

www.lemo.com

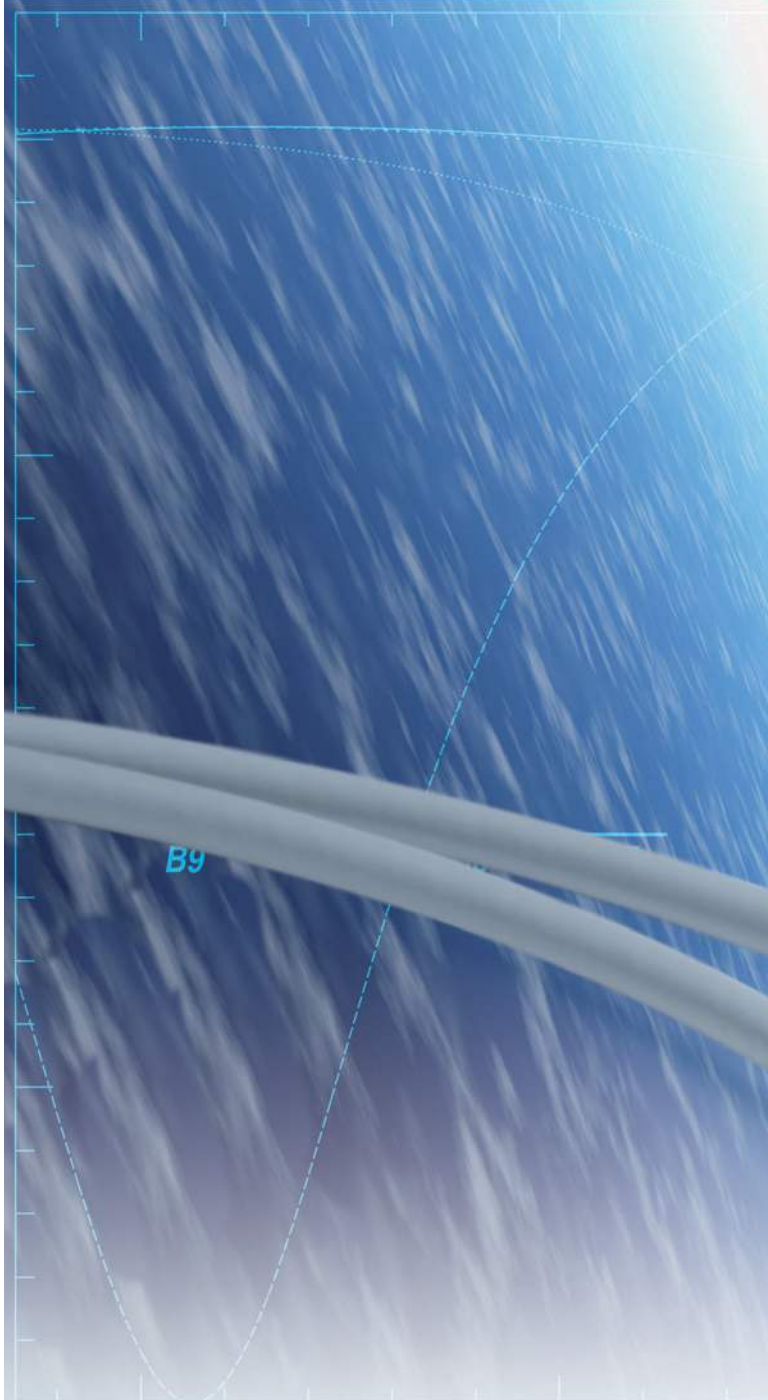

230

235