

ELECTRICAL	MECHANICAL	ENVIRONMENTAL
IMPEDANCE <u>50 Ohm</u> FREQUENCY RANGE <u>DC to 6GHz</u> DIELECTRIC WITHSTAND VOLTAGE: <u>MAX. 2500 V RMS</u> INSULATION RESISTANCE: <u>MIN. 5000 Mohms</u> PIM3: <u>Max. -160dBc @2x20W(43dBm),</u> <u>and 900MHz, 1800MHz, 2100MHz</u>	MATING CYCLES: <u>MIN. 100 cycles</u> RECOMMEND TORQUE: <u>5Nm</u> BENDING RADIUS: <u>SINGLE 17mm</u> <u>REPEATED 55mm</u> CABLE PULLING: <u>MIN. 500N</u> CABLE TORSION: <u>MIN. 5N.m</u>	TEMPERATURE RANGE: <u>-40°~+85°C</u> SALT SPRAY: <u>96H</u> INTERFACE SEAL: <u>IP68(1m, 24h) MATED</u>

P	LTR	DESCRIPTION	DATE	DWN	APVD

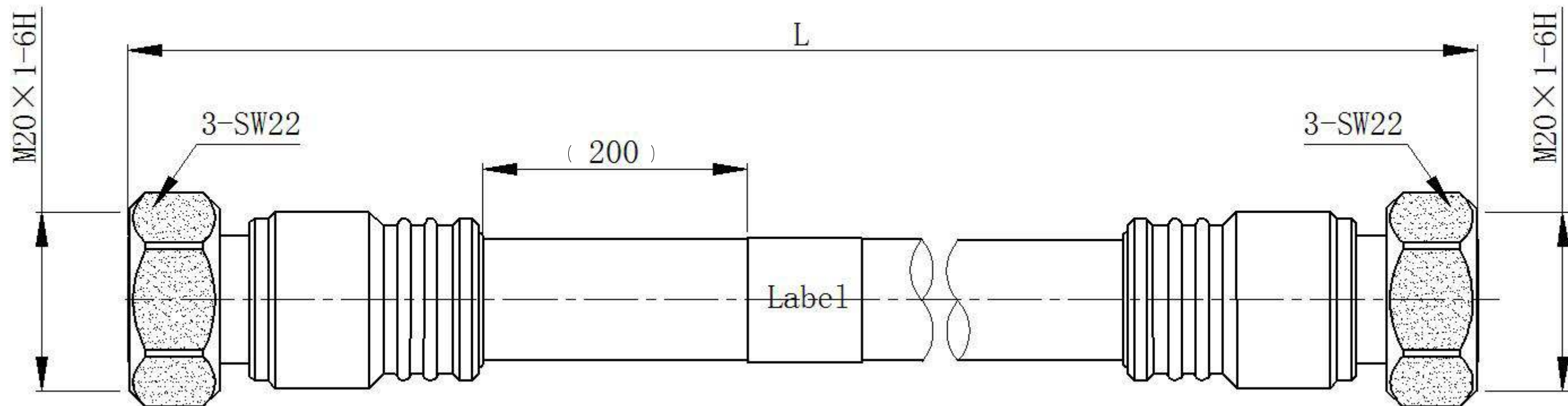

P/N	"L"	INSERTION LOSS	VSWR
2081975-1	1000+/-10	$\leq 0.39\text{dB}@0-3\text{GHZ}$ $\leq 0.59\text{dB}@3-6\text{GHZ}$	$\leq 1.15@0-3\text{GHZ}$ $\leq 1.20@0-6\text{GHZ}$

ITEM	BOM	PART NAME	MATERIAL	PLATING
1	CONNECTOR (x2)	CENTER CONTACT	BRASS	SILVER
		OUTER CONTACT	BRASS	WHITE BRONZE
		INSULATOR	PTFE	
		O-RING	SILICONE RUBBER	
		OTHERS	BRASS	NICKEL
2	CABLE	1/2" SUPERFLEX CABLE WITH BLACK PE JACKET		
3	MOLDING	BLACK PE		
4	LABEL	WRAP STICK TYPE		

THIS DRAWING IS A CONTROLLED DOCUMENT.		DWN JZ 10MAR2020	TE Connectivity		
DIMENSIONS: mm		CHK RZ 10MAR2020			
		APVD RS 10MAR2020	NAME CABLE ASSEMBLY 4.3-10 STR PLUG TO 4.3-10 STR PLUG WITH 1/2 SUPERFLEX CABLE		
TOLERANCES UNLESS OTHERWISE SPECIFIED: 0 PLC ±0.3 1 PLC ±0.2 2 PLC ±0.2 3 PLC ±0.2 4 PLC ±0.2 ANGLES ±		PRODUCT SPEC 108-115175	SIZE A3	CAGE CODE 00779	DRAWING NO C-2081975
MATERIAL SEE TABLE		FINISH SEE TABLE	APPLIC. SPEC -	RESTRICTED TO -	WEIGHT 215g
-		CUSTOMER DRAWING		SCALE 1:1	SHEET 1 OF 2
-		-		REV A	

REVISIONS

P	LTR	DESCRIPTION	DATE	DWN	APVD

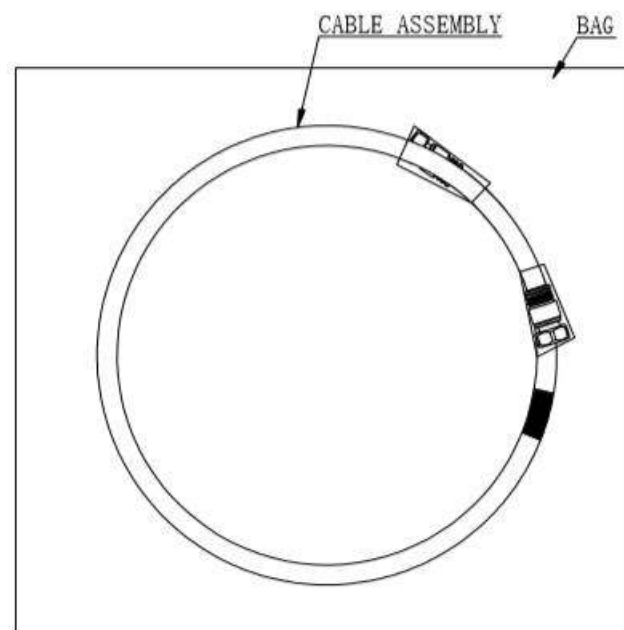

ONE BAG FOR EACH CABLE ASSEMBLY

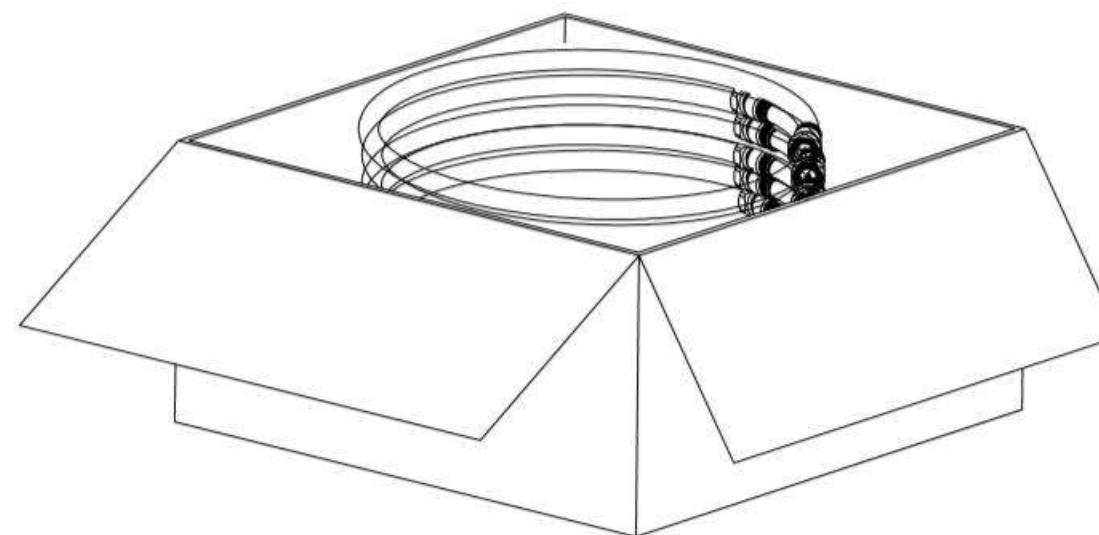

OUTER BOX (22PCS/BOX)

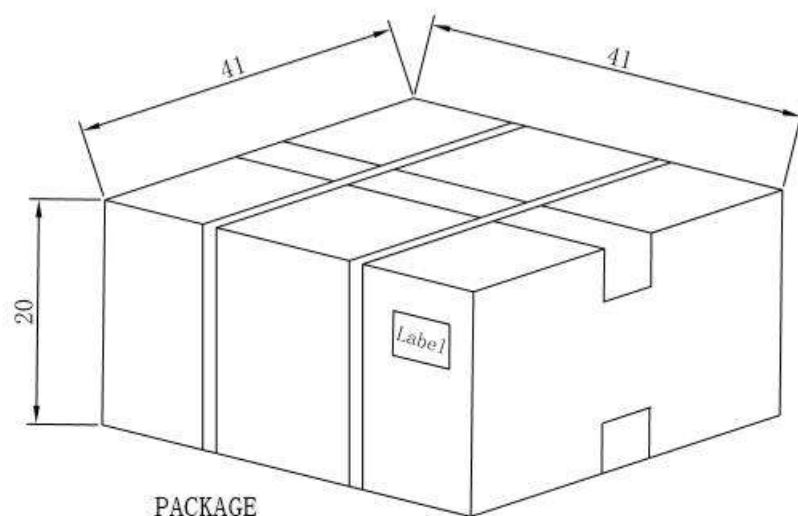

PACKAGE

(BOX SIZE ONLY FOR REFERENCE, UNIT: CM)

THIS DRAWING IS A CONTROLLED DOCUMENT.		DWN JZ	10MAR2020														
DIMENSIONS: mm		CHK RZ	10MAR2020														
TOLERANCES UNLESS OTHERWISE SPECIFIED:		APVD RS	10MAR2020	NAME CABLE ASSEMBLY													
<table border="0"> <tr><td>0 PLC</td><td>±0.3</td></tr> <tr><td>1 PLC</td><td>±0.2</td></tr> <tr><td>2 PLC</td><td>±0.2</td></tr> <tr><td>3 PLC</td><td>±0.2</td></tr> <tr><td>4 PLC</td><td>±0.2</td></tr> <tr><td>ANGLES</td><td>±</td></tr> </table>		0 PLC	±0.3	1 PLC	±0.2	2 PLC	±0.2	3 PLC	±0.2	4 PLC	±0.2	ANGLES	±	PRODUCT SPEC 108-115175		4.3-10 STR PLUG TO 4.3-10 STR PLUG WITH 1/2 SUPERFLEX CABLE	
0 PLC	±0.3																
1 PLC	±0.2																
2 PLC	±0.2																
3 PLC	±0.2																
4 PLC	±0.2																
ANGLES	±																
MATERIAL SEE TABLE		APPLICATION SPEC -		SIZE A3	CAGE CODE 00779												
FINISH SEE TABLE		WEIGHT 230g		DRAWING NO C-2081975	RESTRICTED TO -												
-		CUSTOMER DRAWING		SCALE 1:1	SHEET 2 OF 2												
-				REV A													