

# LINOS X 95 System

## Products and Applications

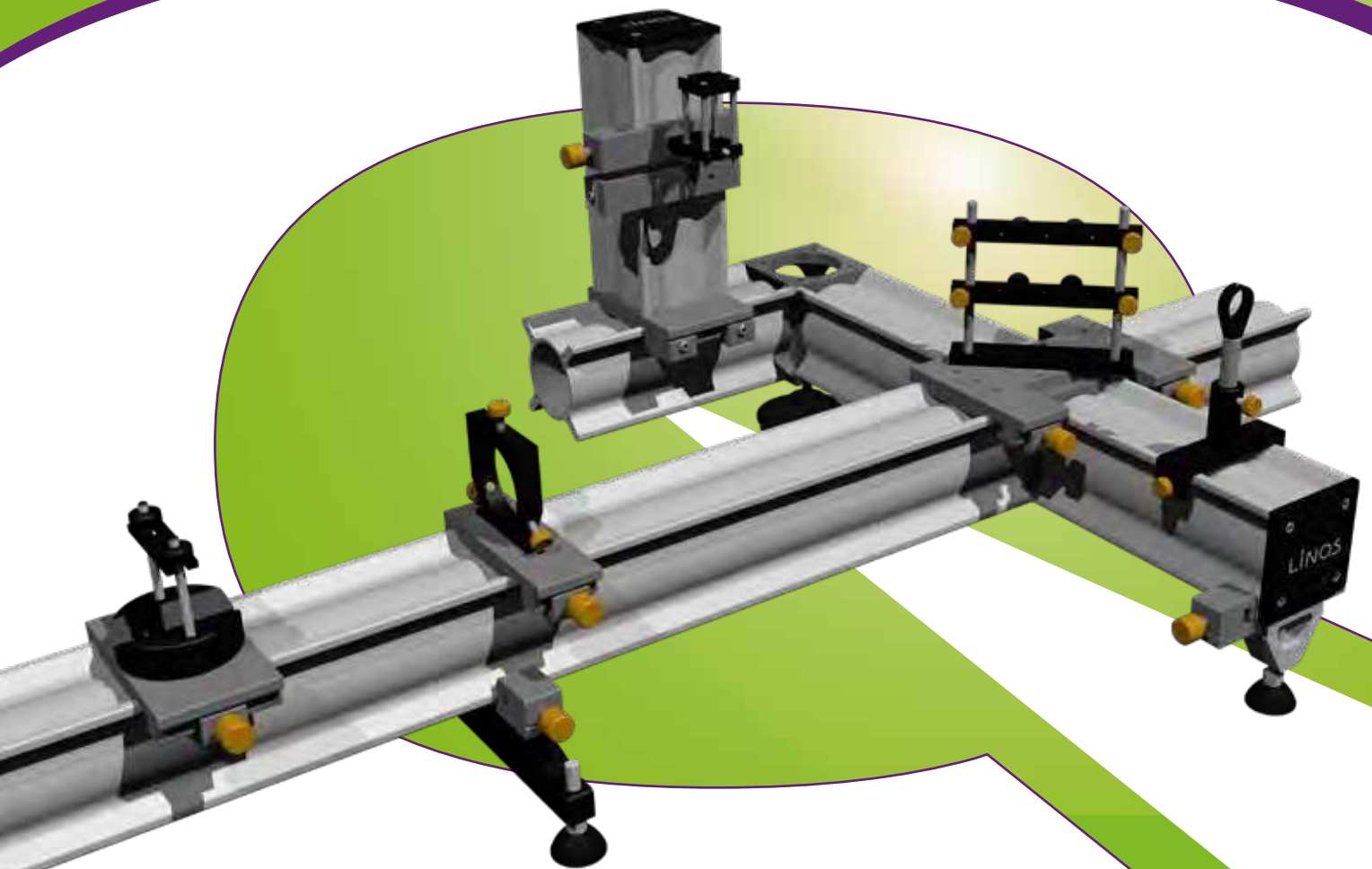

## Company Profile

As a proud member of Excelitas Technologies, Qioptiq designs and manufactures photonic products and solutions that serve a wide range of markets and applications in the areas of medical and life sciences, industrial manufacturing, defense and aerospace, and research and development.

Qioptiq benefits from having integrated the knowledge and experience of Avimo, Gsänger, LINOS, Optem, Point Source, Rodenstock, Spindler &

Hoyer and others. In October 2013, Qioptiq was acquired by Excelitas Technologies Corp., a global technology leader focused on delivering innovative, customized solutions to meet the lighting, detection and other high-performance technology needs of OEM customers. The combined companies have approximately 7,000 employees in North America, Europe and Asia, serving customers across the world.

Visit [www.excelitas.com](http://www.excelitas.com) for more information.

1877



Rodenstock  
founded

1898



Spindler & Hoyer  
founded

1966

Pilkington PE  
Ltd. founded,  
which later  
becomes THA-  
LES Optics

1969



Gsänger  
Optoelektronik  
founded

1984



Optem  
International  
founded

1991



Point Source  
founded

1996



LINOS founded  
through the merger  
of Spindler & Hoyer,  
Steeg & Reuter  
Präzisionsoptik,  
Franke Optik and  
Gsänger Optoelektronik



BIOMEDICAL

CONSUMER  
PRODUCTS

SEMICONDUCTOR

SCIENTIFIC &  
ANALYTICAL

INDUSTRIAL

DEFENSE &  
AEROSPACE

## Content

Company Profile	02 - 03
Introduction	04
Application Examples	05 - 06
Profile X 95	07
Carriers X 95	08 - 12
Mounting Components	13 - 17
Feet, Legs and Stands	18 - 21
Flat Rail System FLR 95	22 - 23
Questions and Answers	24 - 27

2000



**R**  
**RODENSTOCK**

Rodenstock  
Präzisionsoptik  
acquired  
by LINOS

2001



**AVIMO**

AVIMO Group  
acquired  
by THALES

2005



Qioptiq  
founded as  
THALES sells  
High Tech  
Optics Group

2006 / 2007



**QIOPTIQ**  
Optics with Intelligence

Qioptiq acquires  
LINOS and Point Source  
as "members of the  
Qioptiq group"

2010



**QIOPTIQ**  
Photonics for Innovation

The new Qioptiq  
consolidates all  
group members  
under one brand

2013



Qioptiq is acquired by  
Excelitas Technologies

**EXCELITAS**  
TECHNOLOGIES®

# X 95 Profile System

The X 95 Profile System includes both profiles and carriers, and is a versatile construction system for optics and precision mechanics. It is particularly well suited as an optical bench, or for table and framework structures.

- Hollow extrusions with cruciform arrangement of longitudinal ribs
- For assembling tables or framework structures and large scale optical benches
- Allows assembling of three-dimensional structures
- Smooth-gliding carriers equipped with spring-loaded clamps
- Fabricated from anodized aluminum



## Special features:

Modularity allows construction of a multitude of tailored designs. Components can easily be combined with other components from our portfolio.

## Ideal areas of application:

X 95 components are ideal for any application that needs stability and flexibility at the same time at any place. Equally suitable for a stable installation in a manufacturing process as well as for flexible and dynamic measurement setups in the laboratory and in the field.

### Your benefit

- Lightweight, modular and robust construction system
- Quick and easy setup
- Short lead times guaranteed
- Compatible to other LINOS systems



Vertical X 95 construction combined with several LINOS components.

## Application Examples

The LINOS X 95 system is characterized by its high stability and versatility. Therefore it is reflected in a multitude of application areas like research, production or education, for example. This section shows a few examples where the system is being used in standard situations but also in more specialized applications.

Fig. 1 shows the usage of the system as a framework structure in a clean-room environment. The profiles are connected via Clamping Carriers to provide highest flexibility in realigning the system to other sizes. Alternatively for a permanent setup also Corner Joints could have been used. In this application the Teflon-coating on the surfaces of the carriers is beneficial since it reduces abrasion caused by moving the carriers along the rails. It also shows that the system can easily be adapted to individual space requirements.

Fig. 2 shows an application where an X 95 profile provides the backbone of a versatile mounting system for an inspection/microscopy application. In this case, the profile holds an Optem Fusion Lens System equipped with an X-Cite light source. Via its Levelling Feet it can compensate for unevenness in the work surface and permit height adjustment of up to 20 mm. An X95 carrier mounted on the base plate of the levelling feet can be used to hold the test object, or for installing or attaching a specific object mount. The microscope stand can be set up vertically to the measurement plane using the 500 mm long X-95 profile. The X95-30 carrier attached to the profile can be used to secure the mount system, preventing slippage and potential damage to the optical system that would result. Because all its components are standard LINOS products, the system can easily be adapted to virtually any measurement task.



Fig. 1: Frame construction in Qioptiq clean-room environment.



Fig. 2: Vertical X 95 construction for our micro-inspection Optem FUSION system.

## Application Examples

The DLR Institute of Aerodynamics and Flow Technology (AS) uses X 95 components for mounting cameras and illumination devices (Fig. 3 and 4) for its research on the aerodynamics of airplane components. The measurement concept is based on recording the motion of individual particles within a fluid allowing to determine the velocity distribution as a function of space around an object.

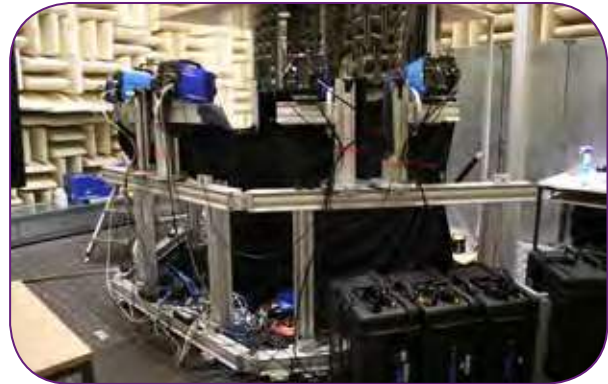

Fig. 3: Solid frame construction for detection equipment at the DLR Institute.



Fig. 4: Installation of DLR's mobile large-scale PIV facility system for flow velocity measurements in the vicinity of the DLR-ALTA research aircraft.

Fig. 5: The OEG GmbH uses X95 components to build their measuring stations. The construction on the right enables the determination of geometric parameters of cylindrical lenses. Two Hinged Connectors allow an oblique mounting of the X 95 profile and the measuring devices are mounted with the help of several X 95 carriers on this profile. The extremely stable and rigid structure of the X 95 profiles and components allow large setups with additional high precision.



Fig. 5 Measuring station for determining geometric parameters of cylindrical lenses out of X95 components built by OEG GmbH.

## Profile X 95

The X 95 profile is a hollow, cylindrical aluminum profile with four lateral ridges which reinforce the system and also hold the carriers. These ridges increase the torque of inertia and torsional strain considerably. Four threaded bore holes on the profile end planes provide fastening options for connectors, carriers or caps. The X 95 profiles are available in many standard lengths. Custom lengths of up to 3 m can be supplied on request.



Profile X 95, 250 mm length

- Allows assembling of three-dimensional structures
- For assembling tables or framework structures or robust optical benches
- Hollow extrusions with cruciform arrangement of longitudinal ribs
- Smooth-gliding carriers equipped with spring-loaded clamps
- Easy assembling

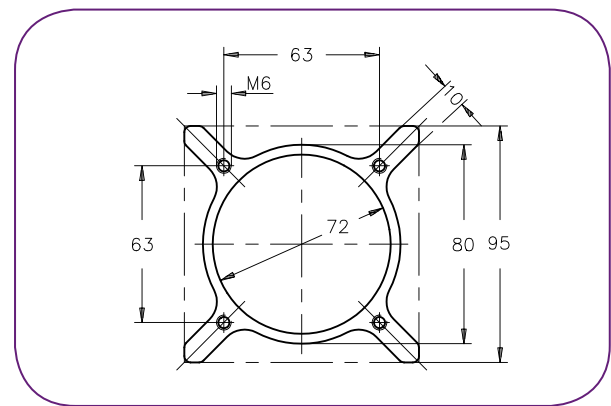

07

## Specifications

- Anodized aluminum
- Moments of inertia  $J_x / J_{\Delta} \sim 220 \times 10^4 \text{ mm}^4$
- Torsional stress  $J_0 \sim 1.2 \text{ kg cm}^2$  per cm length
- Young's modulus  $E \sim 70 \text{ kN/mm}^2$
- Tolerance warpage 0.5 mm/m
- Tolerance twist 0.6 mm/m

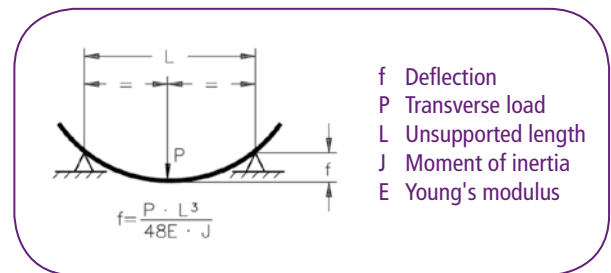

Item Title	Length (mm)	Length (feet)	Weight (kg)	Part No.
Profile X 95- 250	250	0.82	1.4	G026102000
Profile X 95- 500	500	1.64	2.7	G026105000
Profile X 95- 640	640	2.10	3.4	G026106000
Profile X 95- 750	750	2.46	4.1	G026107000
Profile X 95- 1000	1000	3.28	5.4	G026110000
Profile X 95- 1500	1500	4.92	8.1	G026115000
Profile X 95- 2000	2000	6.56	10.8	G026120000
Profile X 95- 2500	2500	8.20	13.5	G026125000
Profile X 95- 3000	3000	9.84	16.2	G026125300
Profile X 95- Custom	Custom	Custom	5.4 per m	On request

## Carriers X 95

The Carriers X 95 can be utilized to mount components onto an X 95 profile. A Teflon film on the bottom side allows a smooth gliding of the carriers on the X 95 rails and therefore provides a precise adjustment. The thumb screws enable a flexible locking and unlocking of the carrier's position without additional tools. The carriers are available with or without hole pattern either with black or with colorless anodizing.

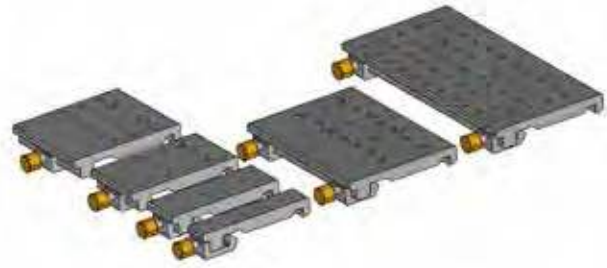

Make your choice!

All carriers X 95 are available in colorless / black / with or without hole pattern.

- Anvil/clamping screw locking mechanism
- Spring-loaded clamps
- Teflon-coated surfaces
- With or without hole pattern
- Anodized black or colorless
- Ø 6.6 mm center bore for posts or similar devices
- M4 mounting threads, 63 mm hole pattern
- M6 threaded hole for top mounting, 25 mm hole pattern
- Bottom mounting with counterbored holes for M4 screws, 25 mm hole pattern

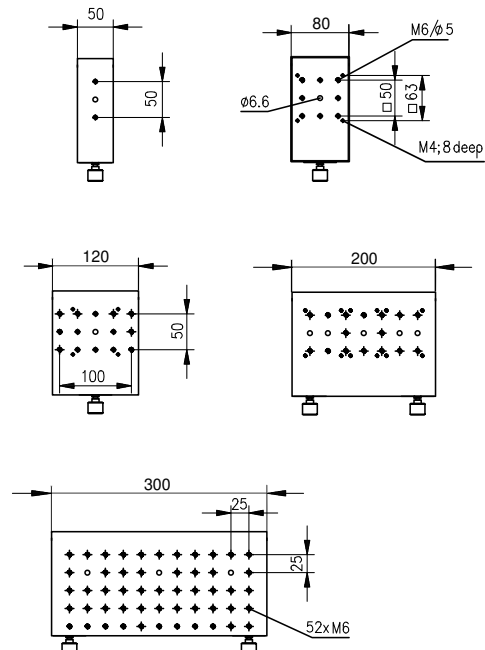
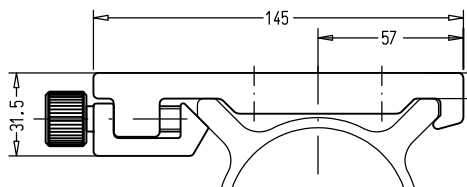

Item Title	Width (B) / mm	Width (B) / inch	Anodized	With hole pattern Part No.	Without hole pattern Part No.
Carrier X 95- 30 colorless	30	1.18	Colorless	G026420000	G026412000
Carrier X 95- 30 black	30	1.18	Black	G026519000	G026512000
Carrier X 95- 50 colorless	50	1.97	Colorless	G026421000	G026413000
Carrier X 95- 50 black	50	1.97	Black	G026521000	G026513000
Carrier X 95- 80 colorless	80	3.15	Colorless	G026422000	G026414000
Carrier X 95- 80 black	80	3.15	Black	G026522000	G026514000
Carrier X 95- 120 colorless	120	4.72	Colorless	G026423000	G026416000
Carrier X 95- 120 black	120	4.72	Black	G026523000	G026516000
Carrier X 95- 200 colorless	200	7.87	Colorless	G026428000	G026417000
Carrier X 95- 200 black	200	7.87	Black	G026528000	G026517000
Carrier X 95- 300 colorless	300	11.81	Colorless	G026429000	G026418000
Carrier X 95- 300 black	300	11.81	Black	G026529000	G026518000



**Carrier Positioner X 95**

The Carrier Positioner X 95 allows the fine alignment of another carrier within a range of 20 mm by pushing it via a plastic tipped screw to the desired position. In addition it can be utilized to mount the Double Leg (G026310000) to an X 95 profile.

- For fine aligning the position of an X 95 carrier (travel: up to 20 mm)
- Ø 6.6 mm center bore for posts or similar devices
- M6 threaded holes for top mounting
- Bottom mounting with counterbored holes for M4 screws, 50 mm hole pattern

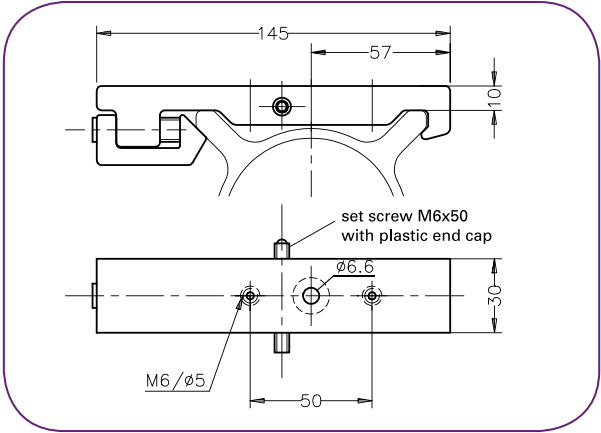

09

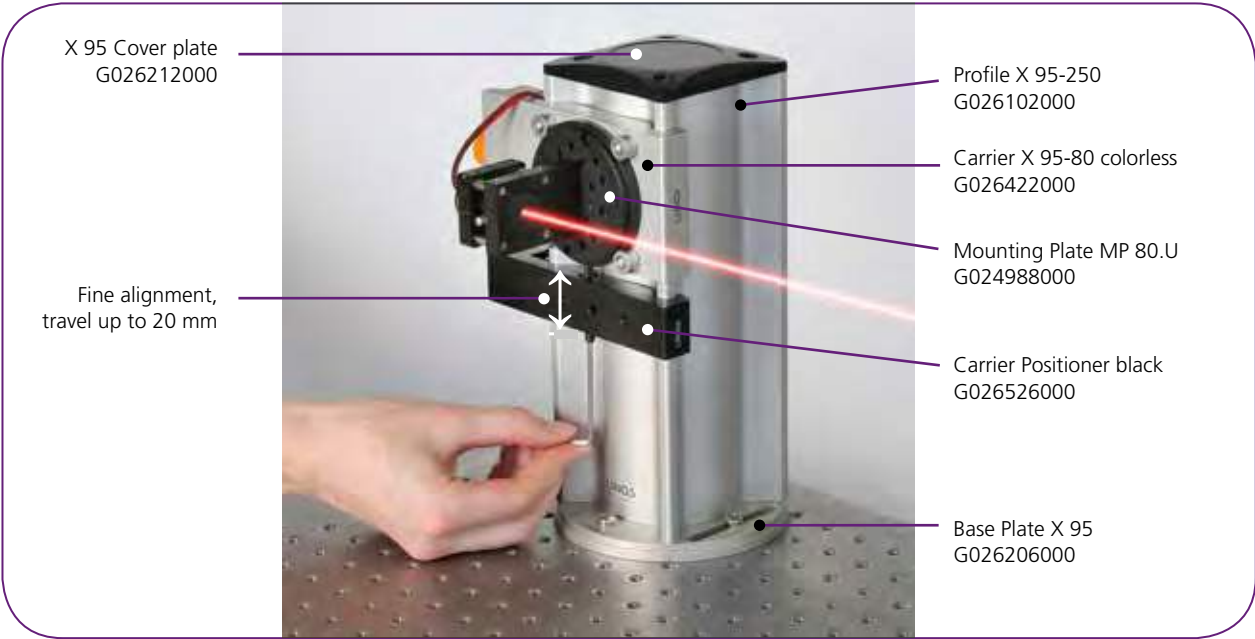

Application example: After slightly loosening the clamping screw on the upper carrier, it can be moved slowly up and down by turning the threaded rod of the lower Carrier Positioner. The vertical height of the mounted laser can be adjusted in this way.

Item Title	Width (B) / mm	Width (B) / inch	Anodized	Part No.
Carrier Positioner colorless	30	1.18	Colorless	G026426000
Carrier Positioner black	30	1.18	Black	G026526000

### Clamping Carrier X 95

The Clamping Carrier X 95 allows the construction of T-shaped structures with X 95 profiles. In contrast to the Carriers X 95 (see page 08), these clamping versions are not equipped with a Teflon film on the bottom side to provide a non-slippery connection to the profiles.

- Building T-structures with X 95 profiles
- Equipped with two anvil clamps
- Ø 11 mm center bore for mounting Levelling Feet
- 63 mm hole grid with Ø 6.6 mm holes

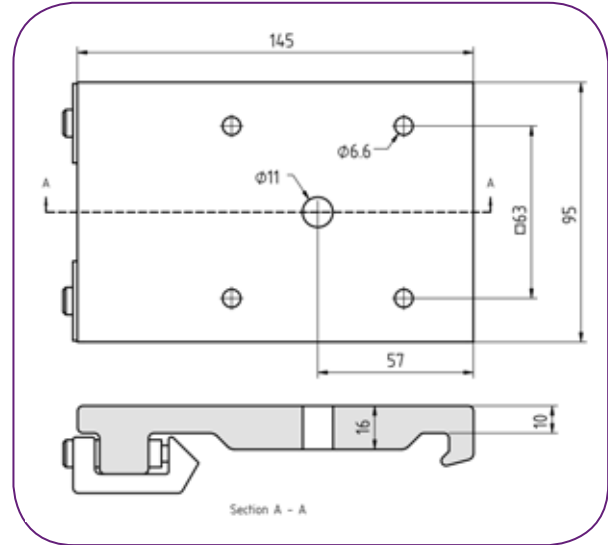

#### A Closer Look

CAD files of all mechanical components can be found at [www.qioptiq-shop.com](http://www.qioptiq-shop.com) under "Docs and Drawings" on the respective product sheets.

Item Title	Width (B) / mm	Width (B) / inch	Anodized	Part No.
Clamping Carrier colorless	95	3.74	Colorless	G026408000
Clamping Carrier black	95	3.74	Black	G026508000

Application example: With the help of clamping carriers it is possible to mount two X 95 profiles vertical to each other wherein the second profile can be moved along the first to the desired position. Finally, it can be fixed there. In the shown example the lower horizontal profile is held by two clamping carriers between two vertical profiles. The upper horizontal profile is held by two corner connectors. To compensate the additional distance, which is generated by the thickness of the clamping carriers, two additional end plates are inserted.



**Cross Carrier X 95**

For mounting components such as beam steering mirrors or beam splitters at the intersection of two optical axes.

- Teflon-coated guide surfaces
- Two anvil clamps for rigid mounting
- Equipped with spring-loaded clamps for smooth gliding actions

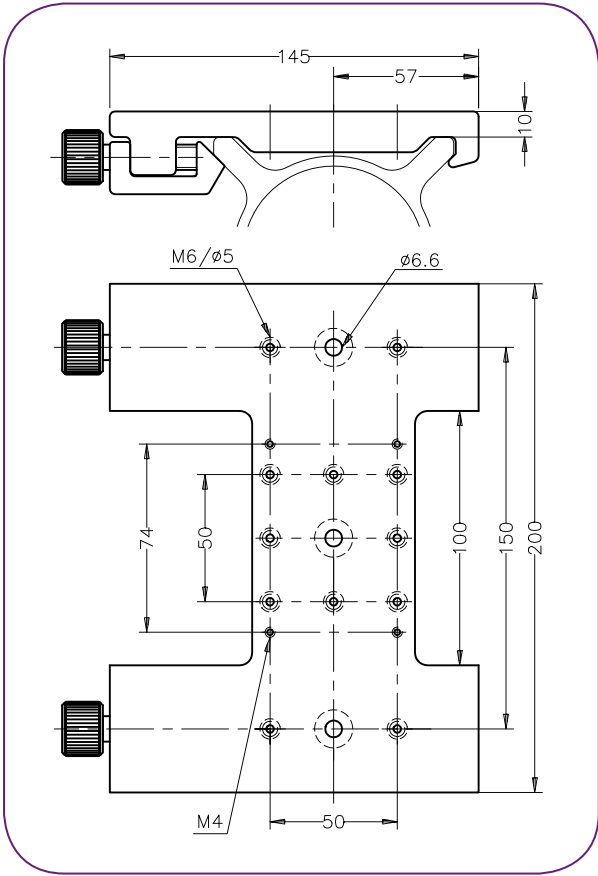
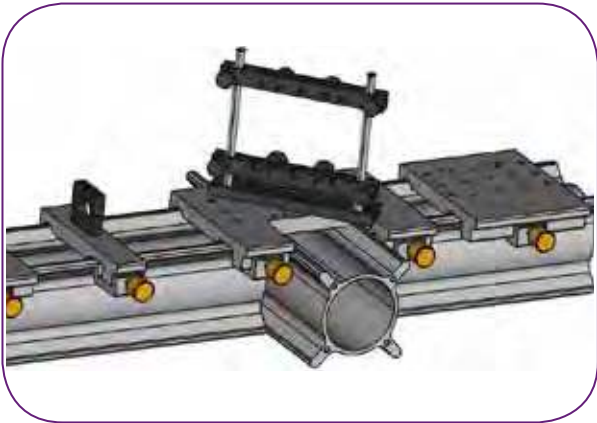

Item Title	Width (B) / mm	Width (B) / inch	Anodized	Part No.
Cross Carrier colorless	200	7.87	Colorless	G026424000
Cross Carrier black	200	7.87	Black	G026524000

### Carrier – Microbench (MB)

This carrier can be used to mount Microbench components directly onto an X 95 profile. Furthermore, posts, etc. can be mounted via the central M6 thread.

- Teflon-coated guide surfaces
- Anvil/clamping screw locking mechanism
- Equipped with spring-loaded clamps for smooth gliding
- Bottom mounting of Microbench mounts
- Central M6 thread
- With counterbored holes for M4 screws

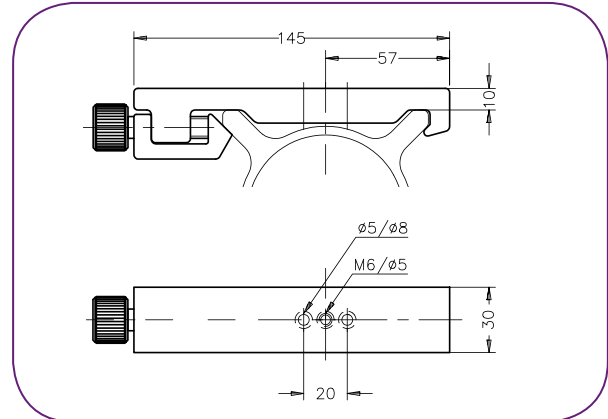

Application example: Both Carriers X 95 - MB are mounted on a Flat rail FLS 95 and each carries a Microbench Holder, which in turn are connected via the Microbench rods.

#### A closer look

This Carrier gives you the connection to our high performance LINOS Microbench system. For more information regarding our LINOS Microbench System ask for your personal copy and write an email to [sales.qioptiq@excelitas.com](mailto:sales.qioptiq@excelitas.com).

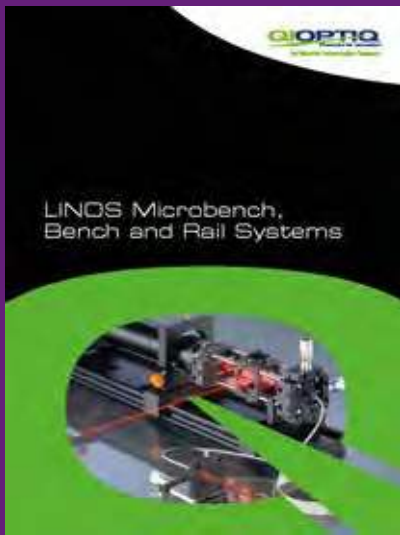

12

Item Title	Width (B) / mm	Width (B) / inch	Anodized	Part No.
Carrier - Microbench colorless	30	1.18	Colorless	G026427000
Carrier - Microbench black	30	1.18	Black	G026527000

## Mounting Plate MP 80.U

- Adapter plate suitable for diverse Microbench components e.g. holder 25 / 30 / 35, rod holder, bench plates
- For prism table 40S/60S
- For linear stages TB 32 / TB 50 / TB 80
- For diverse object and mirror holders
- Mountable on mounting bases without clamps
- To assemble on carrier FLR 95 and carrier X 95 with help of clamps SP 4, G085922000
- Ø 80 mm / 10 mm thick



Item Title	Part No.
Mounting Plate MP 80.U	G024988000

### A closer look

This Mounting plate gives you the connection to our high performance LINOS Microbench system as well as to diverse Stages and Holders.

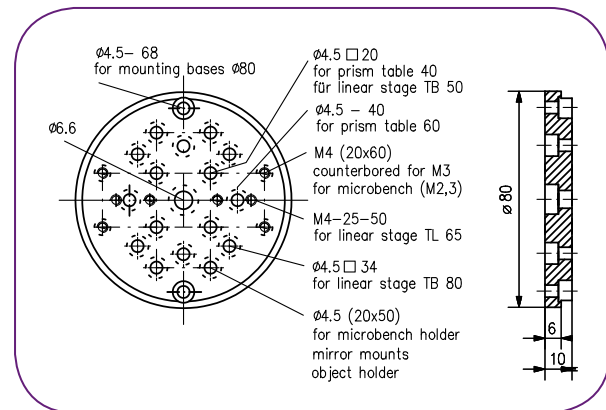

13



Application example: The Mounting Plate MP 80.U is fixed on the carrier by 4 clamps. By slightly loosening the clamps on the edge of the plate it is possible to rotate the plate at any angle around the vertical axis. The different hole patterns in the plate enable a flexible use of different components.

## Base Plate X 95

- Flexible positioning with slotted holes for perpendicular mounting of profiles onto e.g. optical tables
- Thickness: 10 mm



### Base plate X 95 (G026206000)

- Colorless anodized aluminum
- Round shape with a diameter of 135 mm
- Easy clamping with Clamps SP4 (Part No. G085922000)

Item Title	Part No.
Base plate X 95	G026206000
Base plate X 95, angular, black anodized	G026205000

### Base plate X 95, angular (G026205000)

- Black anodized aluminum
- Quadratic shape with 120 mm x 120 mm

14

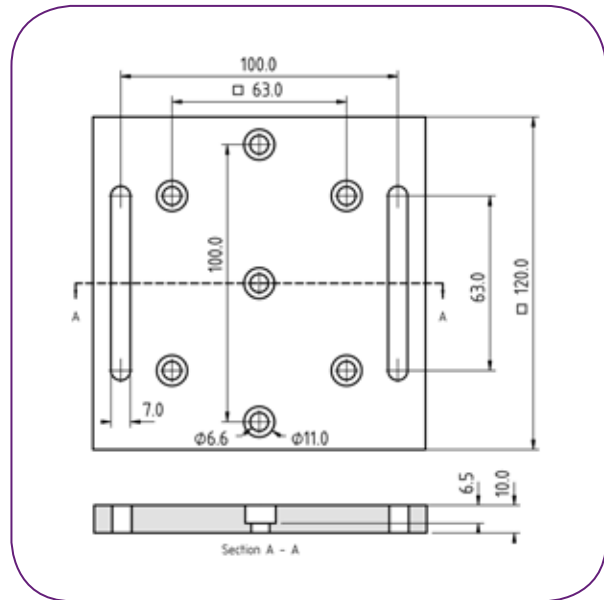
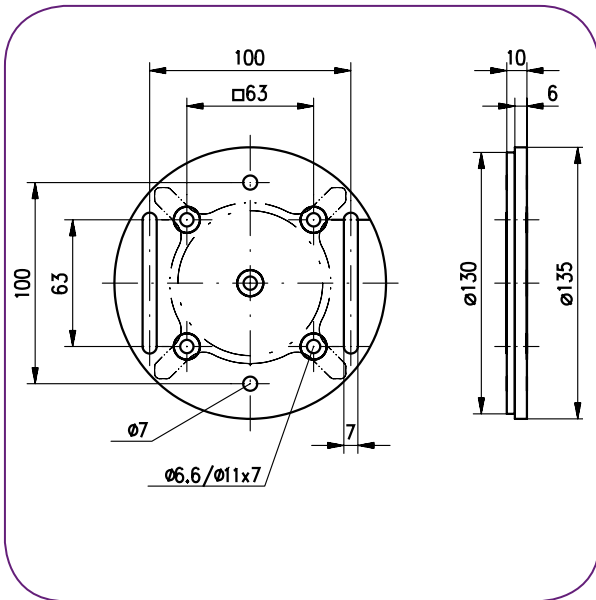

### Application example

How to mount vertical X 95 profiles on optical tables with the help of the mounting plate can be seen in the application example on page 9.

### X 95 End Plate

- Caps ends of profiles
- Acts as a stop for carriers
- For mounting X 95 profile structures on Levelling Feet
- Includes 6 ea. M6x16 Allen-head screws

Item Title	Part No.
End Plate	G026201000

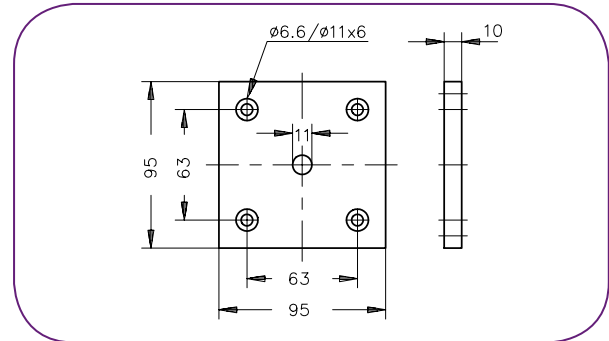

15

### X 95 Corner Joint

- Cubic coupler for assembling framework structures
- 5 faces each have diameter 6.6 mm holes for bolting coupler onto end of X 95 profile
- Other face has 4 M6 tapped holes for installing an X 95 clamping carrier

Item Title	Part No.
Corner Joint	G026210000



Application example how to build a rectangular angle

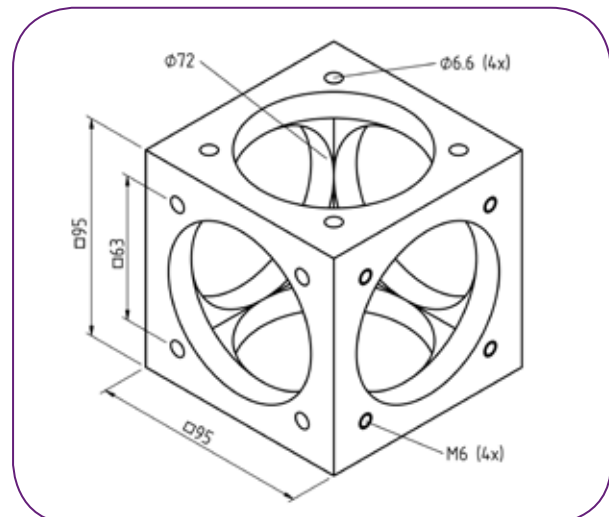

## X 95 Cover Plate

- For blanking off unused faces of Corner Joints or open ends of X 95 profiles
- Supplied with 4 fastening screws
- Black anodized aluminum



Item Title	Part No.
Cover Plate	G026212000

### Standard Plus

For volume orders have the cover plate engraved with your logo!

16

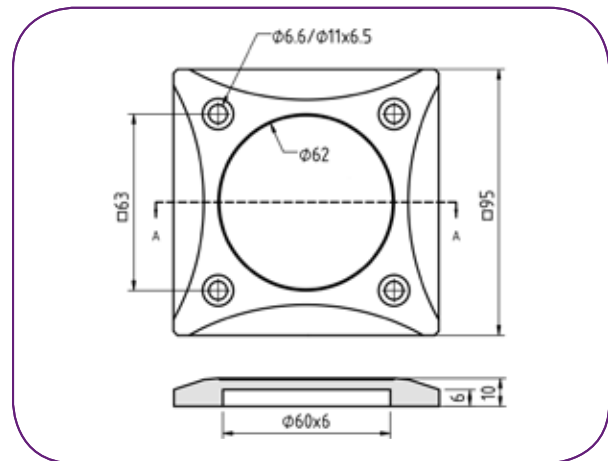

Application Example: The Cover Plate X 95 closes one end of a Profile X 95.



### X 95 Hinged Connector

- Allows for angle variation between two X 95 profiles
- Used as a cross brace for X 95 structures
- Supplied complete with mounting screws
- $\pm 90^\circ$  pivot

Item Title	Part No.
Hinged Connector	G026218000

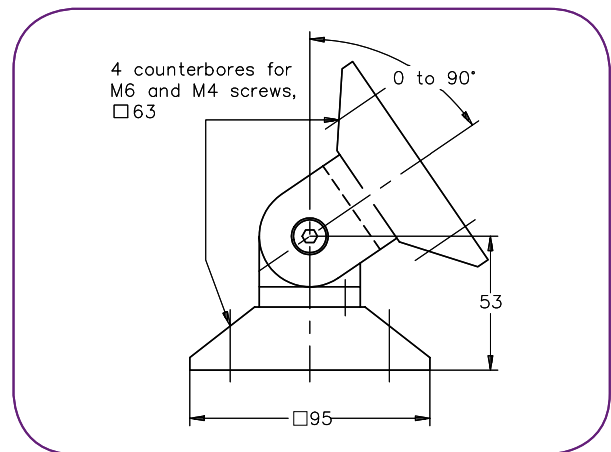

Application example for X 95 Hinged Connector: One connects two X95 Profiles, the other connects a X95 Profil with X 95 Clamping Carrier.

## X 95 Levelling Foot

The Levelling Foot provides a way to isolate a X 95 structure against vibrations. Combined with its high load capacity it is well suited as a foot for framework structures.

- Laminated vibration isolator plate:  
diameter 100 mm, 15 mm thick
- Maximum load capacity of 3.5 kN
- Height adjustment by turning the lower nut

### Levelling foot X 95 (G026202000):

- For mounting vertical orientated X 95 Profiles
- Included End plate allows direct mounting to X 95 profile
- Levelling range: 30 mm

### Levelling disc X 95 (G026261000):

- For mounting horizontal orientated X 95 Profiles along with Clamping Carrier (G026408000)
- Levelling range: 6 mm

Item Title	Part No.
Levelling foot	G026202000
Levelling disk	G026261000

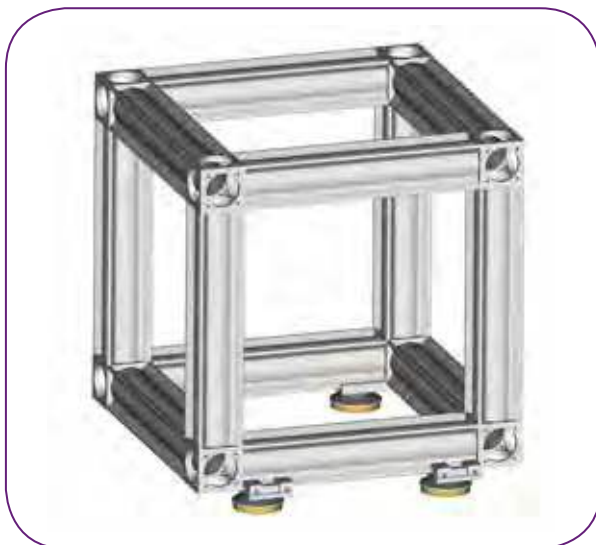

Application example: Horizontal X 95 Profiles can be put on dampening Levelling discs by mounting Clamping carriers (G026408000) on the profiles.



Levelling foot X 95

Application Example: Vertical X 95 profiles can be mounted with their front side on the Levelling foot.

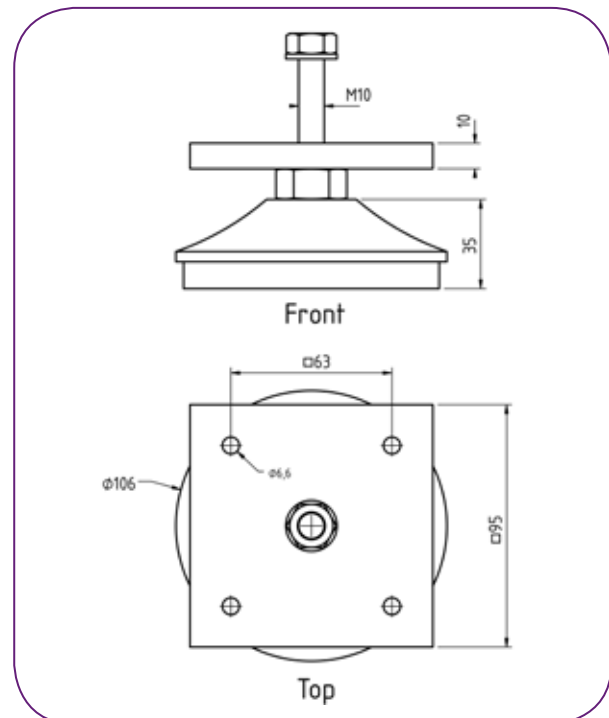

Levelling foot X 95



Levelling disk X 95

### X 95 Single Leg

- Height adjustable (approx.  $\pm 10$  mm)
- Swivel levelling pads supplied with screws
- Requires Carrier X 95 for mounting (not included)

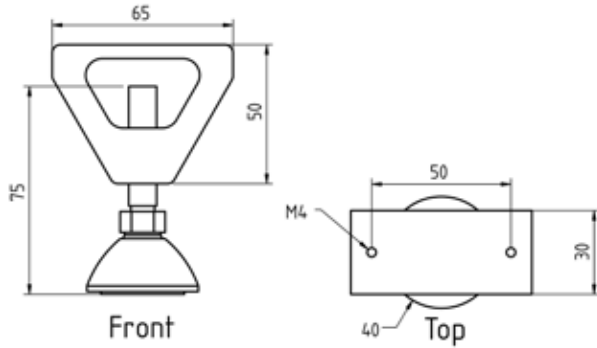

Item Title	Part No.
Single Leg	G026304000

### X 95 Double Leg

- Height adjustable (approx.  $\pm 10$  mm)
- Swivel levelling pads
- Supplied with screws
- Requires Carrier X 95 for mounting (not included)

Item Title	Part No.
Double Leg	G026310000

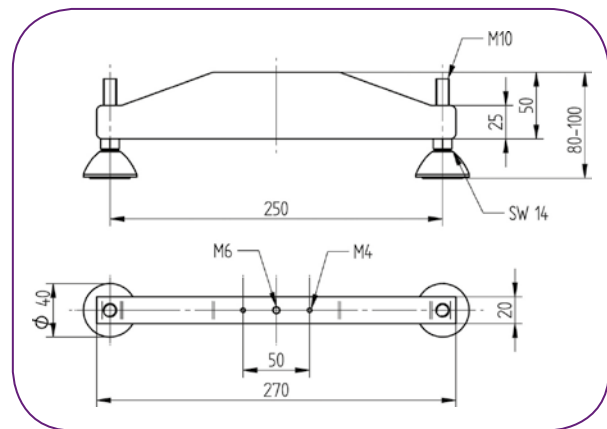

**Mounting Base**

- Stable base for mounting posts (such as post 38) or vertically mounting X 95 profiles
- Machined flat mounting surface, 95 mm wide
- M6 threaded mounting holes for mounting plates and low profile rail, G022080000 etc.
- Levelling feet with a height adjustment up to 20 mm

Item Title	Part No.
Mounting Base	G024343000



**A Closer Look**

Please have a look on page 5 regarding an application example of a vertical X 95 construction with the help of the mounting base.

20

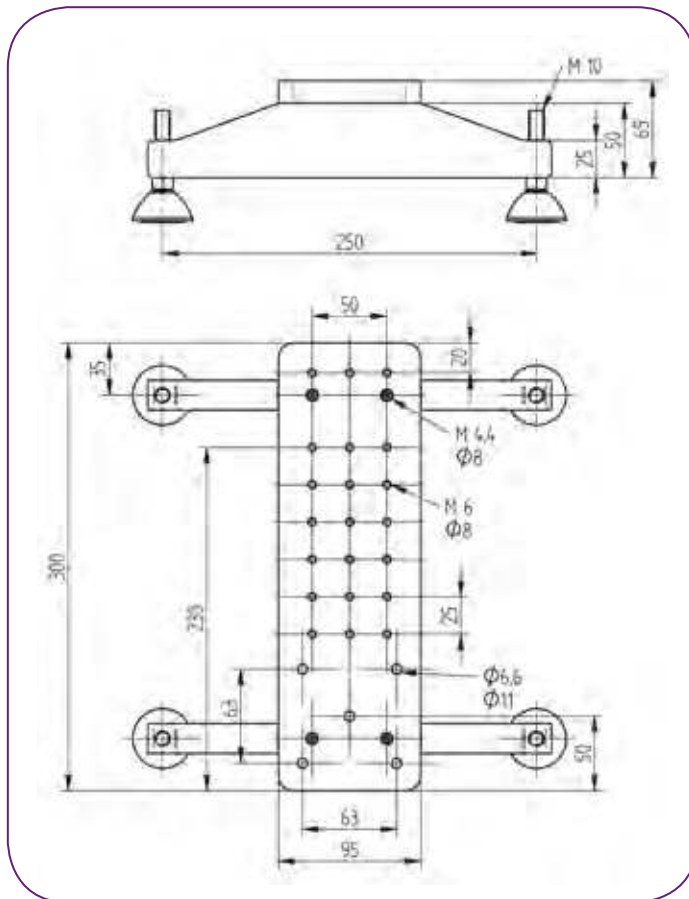

## X 95 Locking Caster

The Locking Caster can be used for mobile X 95 structures. It can be mounted directly to one end of a profile or to a Corner Joint.

- Caster with integrated, stable foot
- Easy to use locking lever
- Load capacity of up to 2 kN
- Mounts on X 95 Corner Joints or ends of X 95 profiles
- Supplied complete with mounting screws



Item Title	Part No.
Locking Caster	G026256000

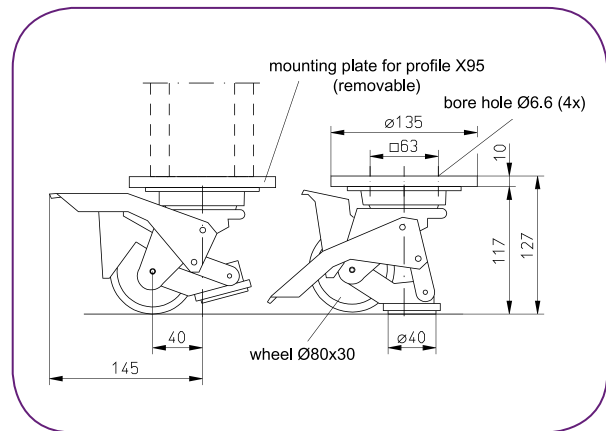

## FLS 95 Rail System

The FLS 95 Rail System is ideal as a flat-profile optical bench, particularly for setups on optical tables. Its slotted holes make it independent of existing hole patterns and fit both M6 and 1/4" screws. The profile corresponds to the X 95 system and can use the same carriers. The rail surface is treated with abrasion-resistant black anodizing and the bearing surfaces are milled to ensure the highest guiding accuracy.

- Flat-profile optical bench
- Ideal for mounting components or instruments
- Lengthwise and crosswise slots in rails allow for readily shifting rail positions
- Extremely rigid
- Rails accept X 95 system components
- Black anodized profiled aluminum rails

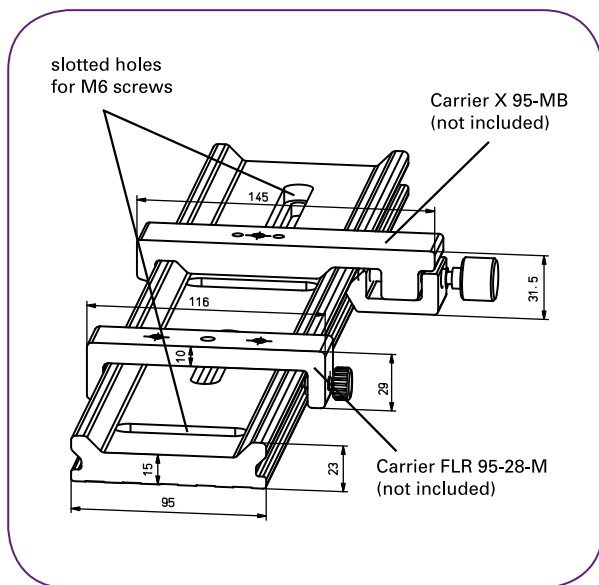
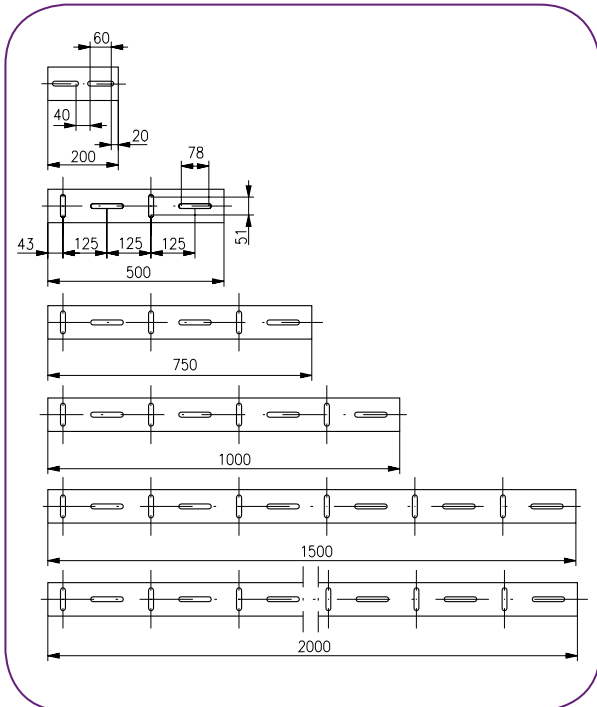

Item Title	Length / mm	Length / feet	Part No.
FLS 95- 200	200	0.66	G022080000
FLS 95- 500	500	1.64	G022081000
FLS 95- 750	750	2.46	G022082000
FLS 95- 1000	1000	3.28	G022083000
FLS 95- 1500	1500	4.92	G022084000
FLS 95- 2000	2000	6.56	G022087000

**Carriers FLR 95**

- Simple carriers for FLS 95 Rail System and X 95 Profile System.
- Fastening of the carriers on the profile via a clamping screw with plastic cone point
- Without spring loaded clamps (for spring loaded carriers see "Carriers X 95")
- Black anodized aluminum



Application example: A Carrier FLR 95 with Mounting Column 14, Rod and Adjustable Holder 55-M is placed on Flat rail FLS 95-200-M.

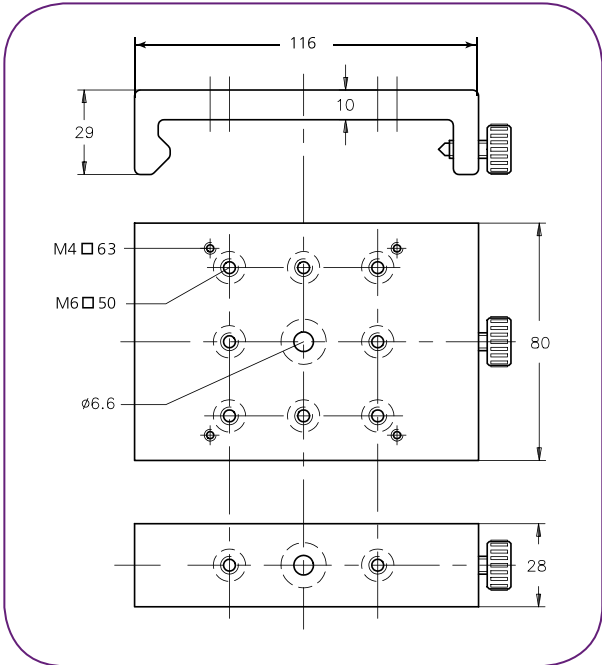

Item Title	Width / mm	Width / inch	Part No.
Carrier FLR 95-28	28	1.10	G022091000
Carrier FLR 95-80	80	3.15	G022092000

## How to Build a Framework Structure

X 95 components are well suited to design and build rigid and robust frameworks and structures. X 95 profiles can be used as a base frame for breadboards, optical workstations, large scale optical setups, and many other applications. Due to the modularity a multitude of various designs is possible, giving you the highest flexibility in building a reliable system tailored to your needs. Due to the rigidity and torque of inertia a framework made of X 95 components can withstand heavy loads and comprises a high robustness.

With the knowledge of the size of the final system, the required profile lengths can be selected or, if necessary, profiles with customized lengths may be used. The profile ends are connected via Corner Joints that allow the attachment of profiles on up to 5 sides via M6 screws (Fig. 1). The sixth side has four tapped holes by which Clamping Carriers can directly be attached. With these components the basic frame can be constructed. If required, also cross bracings can be inserted to increase the stability of the system (Fig. 2). To integrate these cross bracings either Clamping Carriers can be used, but also inclined connections are possible by using a Hinged Connector (Fig. 3). Furthermore, the Carriers can be used to build T-shaped structures (Fig. 4) or to mount X 95 profiles onto each other (Fig. 5).

24

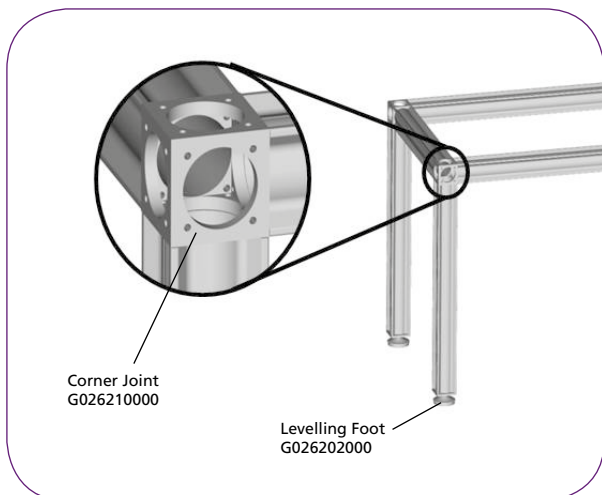

Fig. 1: Connecting profiles via Corner Joints.



Fig. 2: Increase the stability of the system via cross bracings.



Fig. 3: Inclined connections via the Hinged Connector.

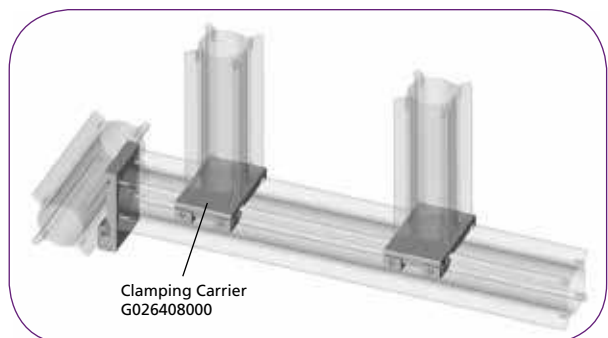

Fig. 4: Building T-shaped structures.



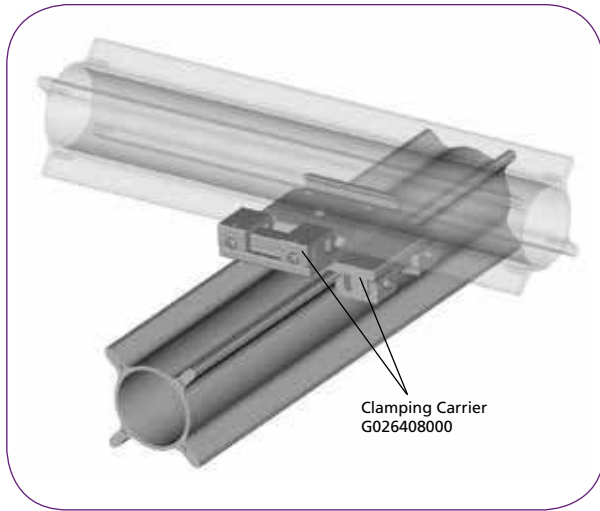

Fig. 5: Mounting two profiles onto each other via carriers. This allows a flexible alignment of the profile's position towards each other. In the same way, the FLS 95 Rail can be connected to the X 95 Profile in right-side-up or upside-down position.

The last step of the construction is to find suitable feet for the framework. Here you can choose from a variety of different versions depending on your demand (Fig. 6):

- Should the framework be isolated against vibrations?
- Does the framework require a permanent fixation to the ground?
- Does it have to be mobile?
- Is it being used for heavy loads?

For details on the various possibilities, please refer to the respective component description.

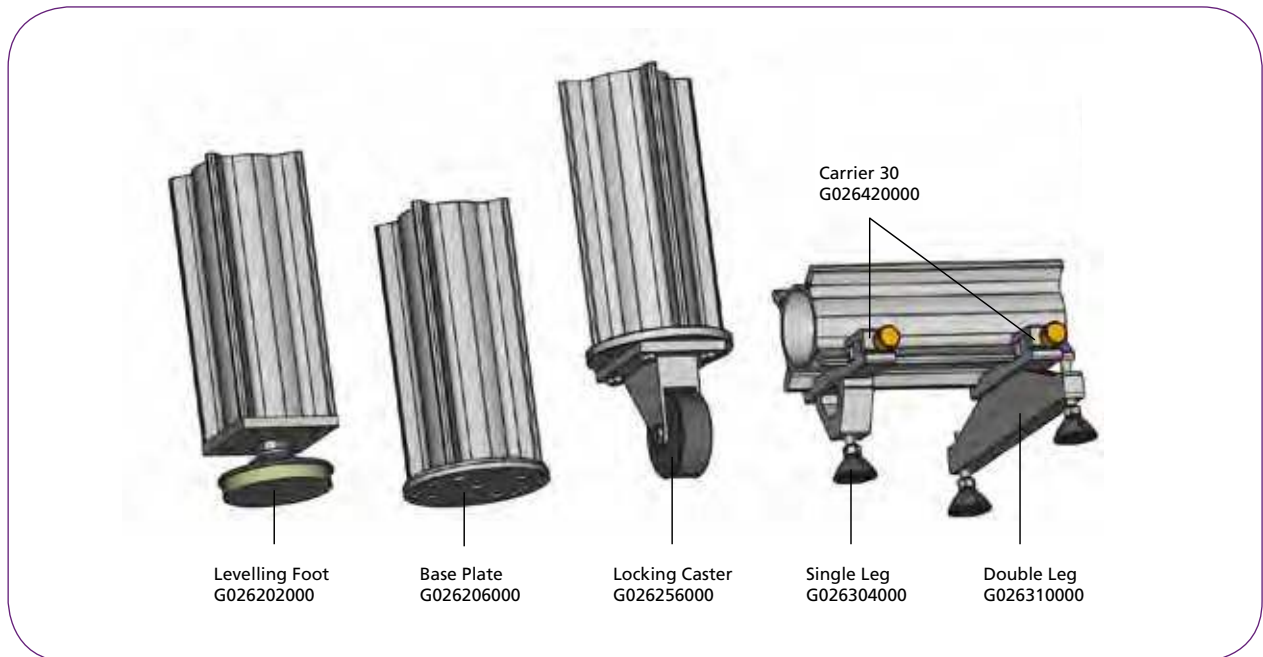

Fig. 6: Selection of different feet for the X 95 system.

## How to Use the X 95 Profiles and Components as an Optical Bench System

Since the profile system can also be used as a modular large scale optical bench system, the portfolio provides a huge variety of ways to mount optical components onto the profiles. Carriers in widths from 30-300 mm that comprise various hole patterns, allowing you to mount Microbench components, holders, posts and other optomechanical mounts, are available.

In addition we offer carriers that allow the fine-alignment of components along the profile axis and a Cross Carrier for the positioning of components at the crossing of two profiles.

By integrating Microbench components or by connecting the X 95 to a Microbench system, you can apply the unsurpassed precision of our Microbench components to the X 95 system. Your benefit is the synergy of the X 95 system's robustness and stability combined with the Microbench's axial accuracy.

26

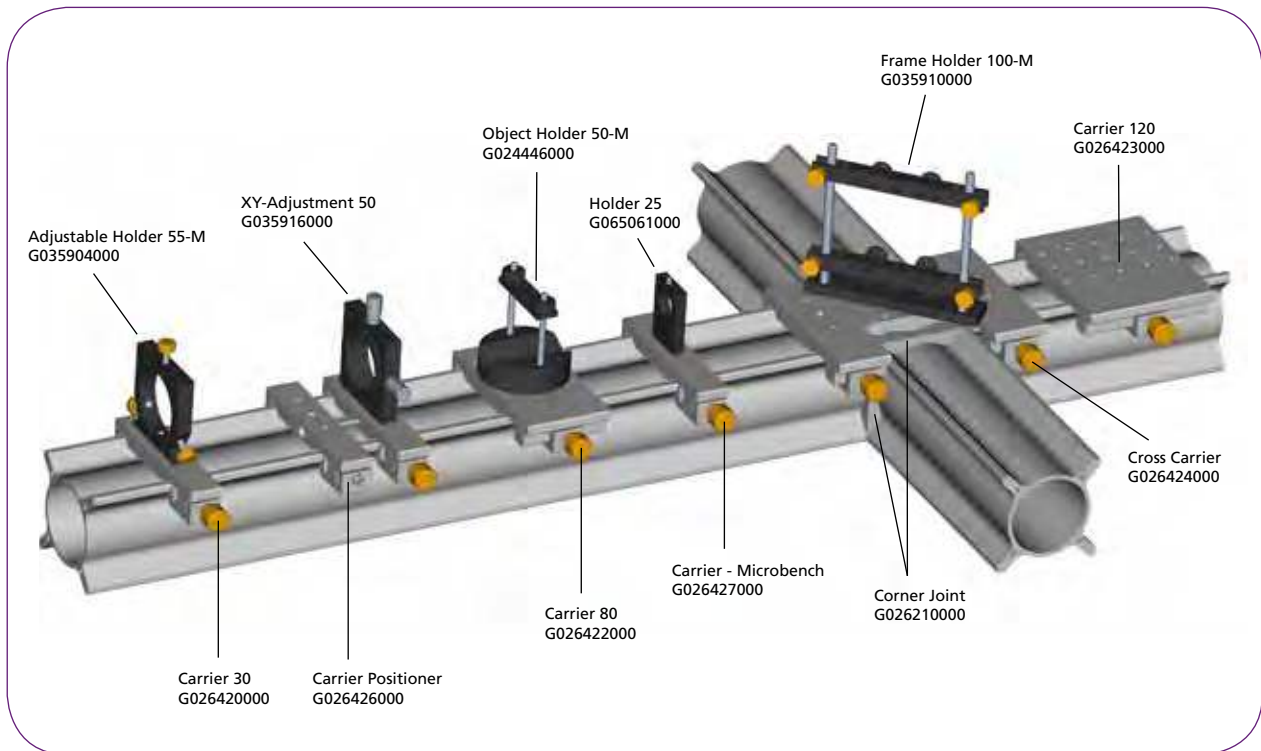
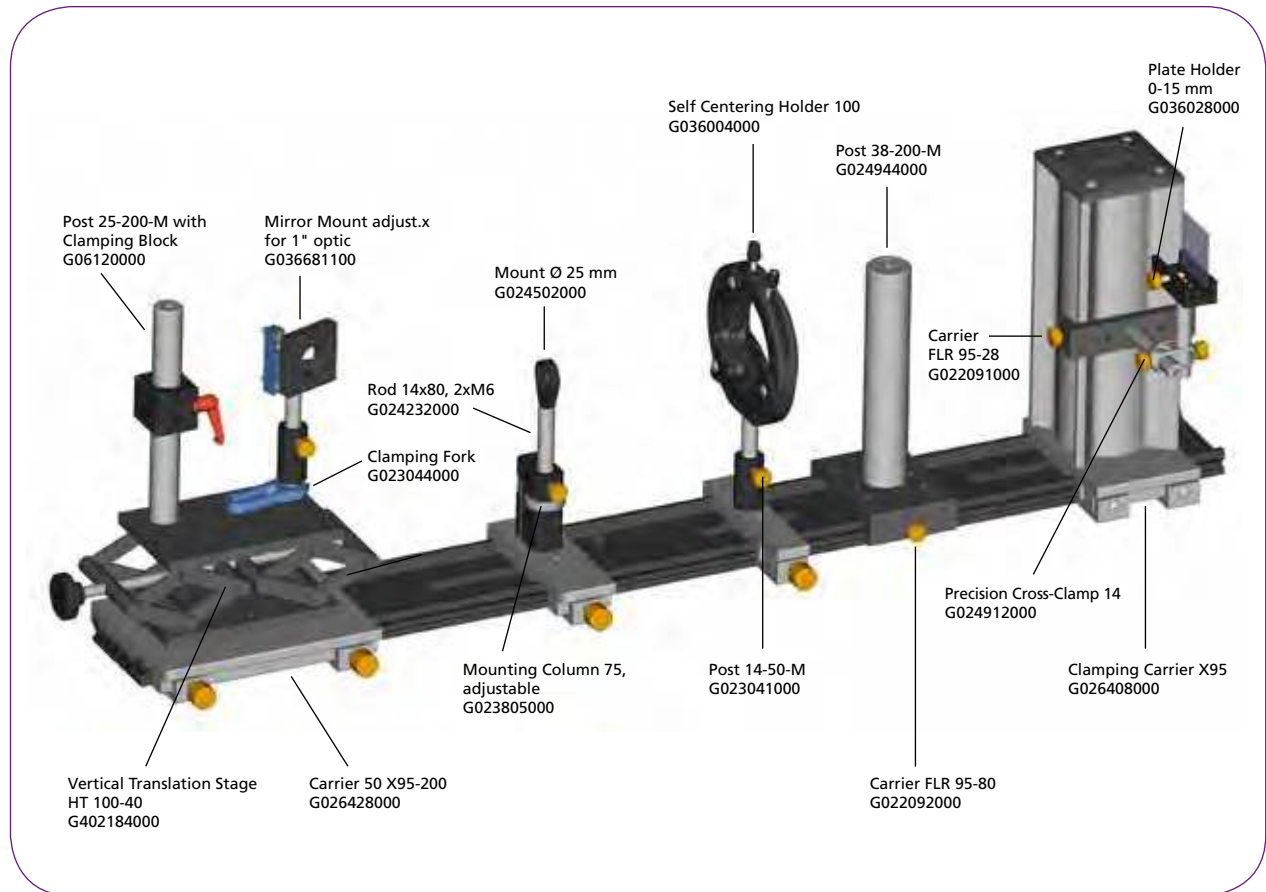

Fig 1: Several optomechanical frames and holders allow the use of the X 95 profiles and carriers as an optical bench system.

## How to Use the FLS 95 Rail System with Various Optomechanical Components



27

Fig 2: Combine the rails and carriers from the Flat Rail System 95 with the X 95 components and various optomechanical components for maximum flexibility in your optical bench set-up.



## Discover the Q!

Qioptiq stands for products of the highest quality, whether off-the-shelf optical and mechanical equipment or customerspecific components and modules. Qioptiq designs and manufactures photonic products and solutions that serve a wide range of markets and applications in the areas of medical and life sciences, industrial manufacturing, defense, and aerospace, as well as in research and development.

## Photonics for Innovation

### Contact Qioptiq today:

[sales.qioptiq@excelitas.com](mailto:sales.qioptiq@excelitas.com)

Europe  
+49 (0) 551 6935-0

North America  
+1 (800) 775 6786

Asia/Pacific  
+65 64 99 7777

[www.excelitas.com](http://www.excelitas.com)