

THIS DRAWING IS UNPUBLISHED. RELEASED FOR PUBLICATION 2008
 © COPYRIGHT 2008 BY TYCO ELECTRONICS CORPORATION. ALL RIGHTS RESERVED.

LOC	DIST	REVISIONS			
P	LTR	DESCRIPTION	DATE	DWN	APVD
F	00	F	DRAFTING DETAIL UPDATE	02DEC2008	LCi JD r
			TYCO FORMAT COMPLIANCE		

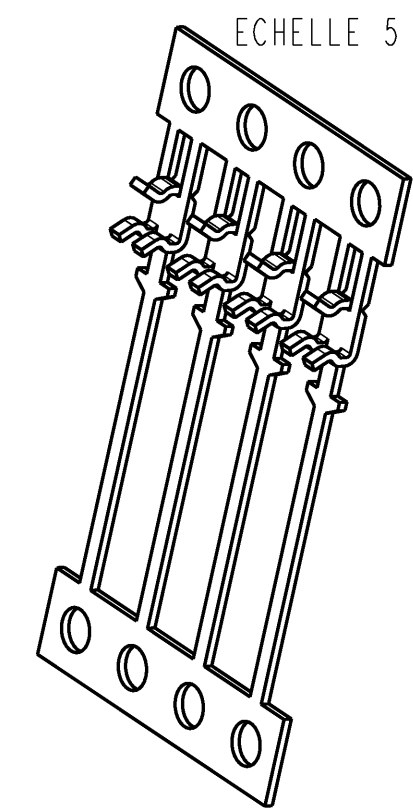
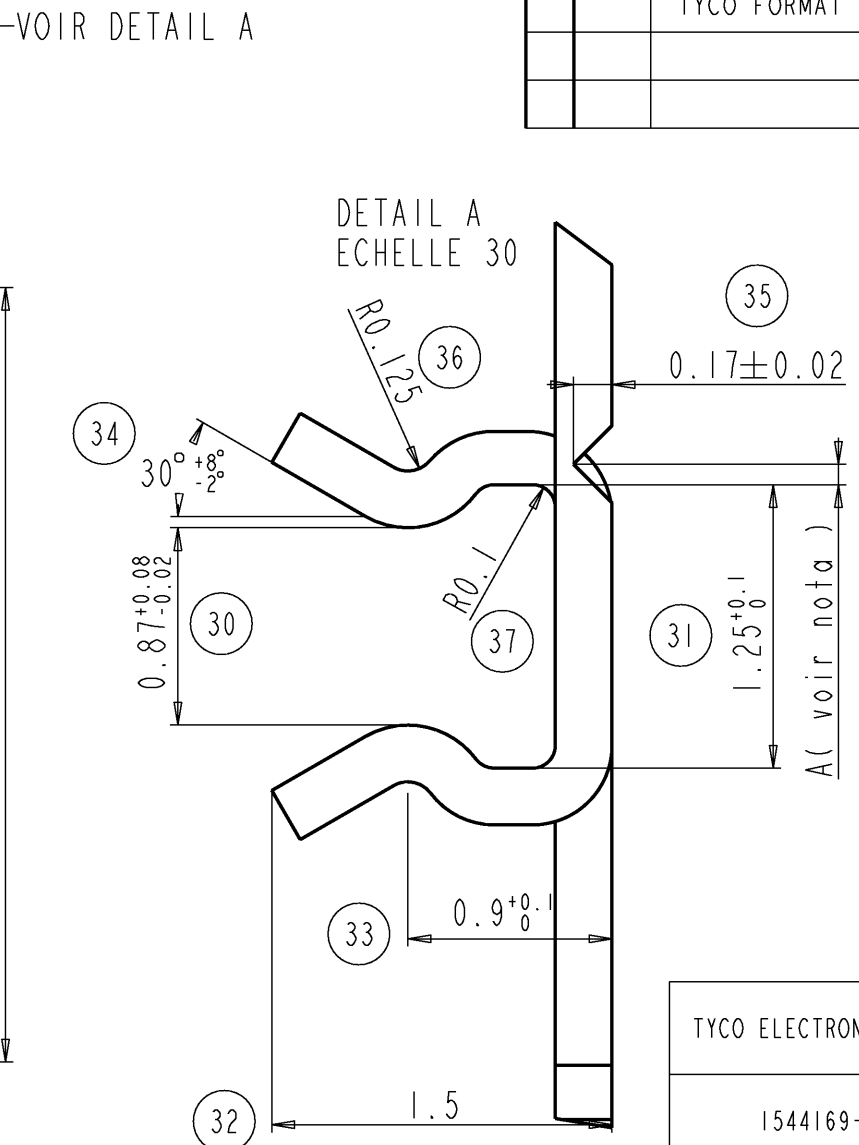
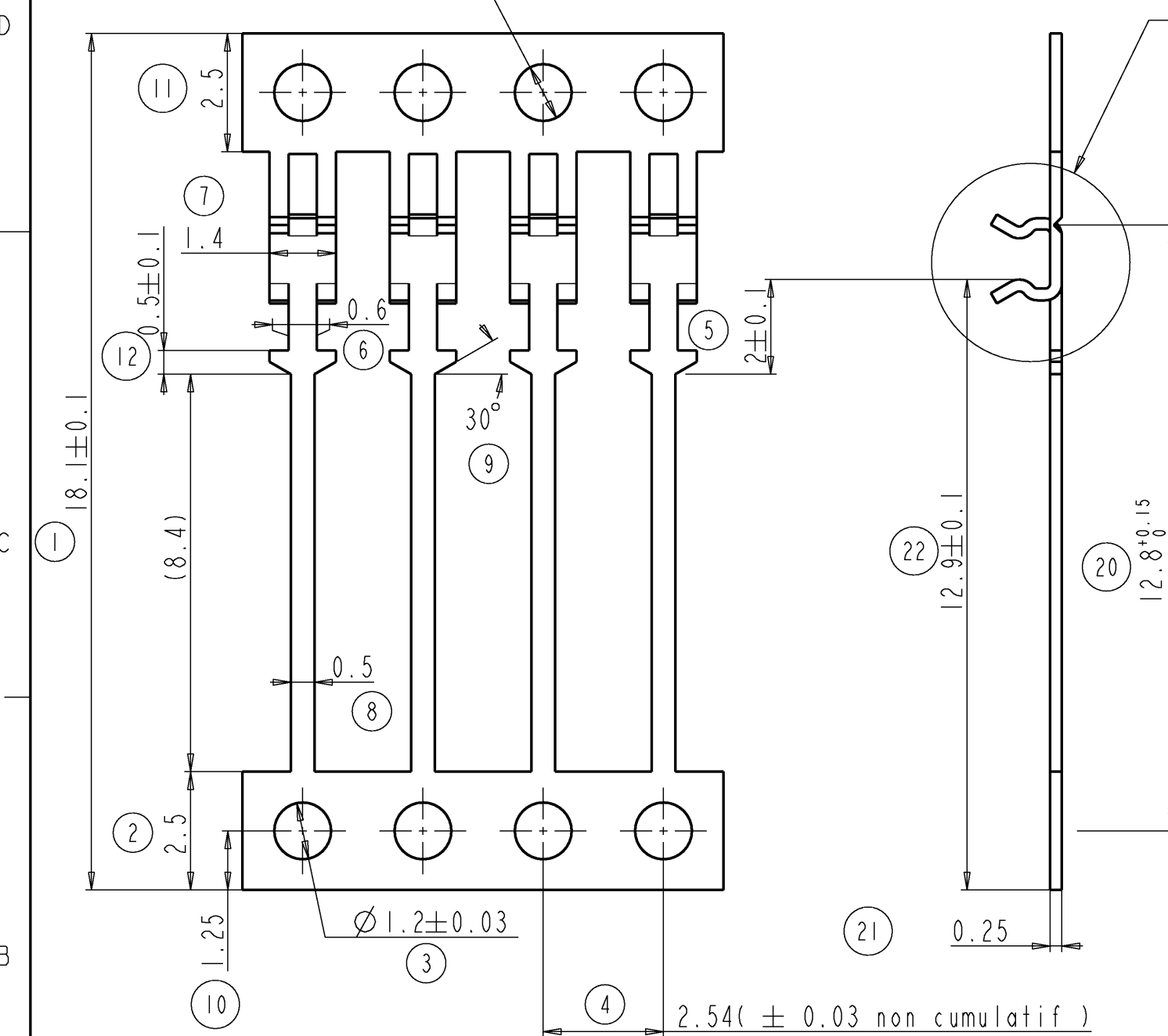

TYCO ELECTRONICS PN	PLATING	WINDING DIRECTION
1544169-1	BEFORE STAMPING Sn : 112-16-4 (3 à 7µ)	1
1544169-2	AFTER STAMPING Ni : 112-25-3 (1.27 à 3µ) Sn : 112-65-1 (3 à 5 µ)	1
1544169-3	BEFORE STAMPING Sn : 112-16-4 (3 à 7µ)	2
1544169-4	AFTER STAMPING Ni : 112-25-3 (1.27 à 3µ) Sn : 112-65-1 (3 à 5 µ)	2

Nota : A, dans tous les cas, l'axe de l'amorce de casse doit être extérieur au fond de pince
 - Volume par contact : 5.32 mm³

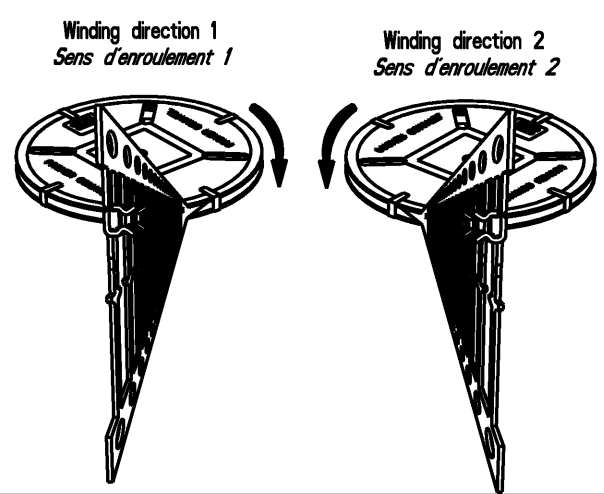

<small>THIS DRAWING IS A CONTROLLED DOCUMENT FOR TYCO ELECTRONICS CORPORATION IT IS SUBJECT TO CHANGE AND THE CONTROLLING ENGINEERING ORGANIZATION SHOULD BE CONTACTED FOR THE LATEST REVISION.</small>		DWN L. CORONELLI 02DEC2008 CHK P. FLORES 02DEC2008 APVD J. DAHER 02DEC2008		Tyco Electronics France SAS RN 90, 38530 Chapareillan																			
DIMENSIONS: mm 		TOLERANCES UNLESS OTHERWISE SPECIFIED: <table border="1"> <tr><td>PL</td><td>±</td></tr> <tr><td>PVC</td><td>±</td></tr> <tr><td>PLC</td><td>±0.05</td></tr> <tr><td>PAC</td><td>±</td></tr> <tr><td>PLC</td><td>±</td></tr> <tr><td>PLC</td><td>±</td></tr> <tr><td>ANGLES</td><td>±3°</td></tr> <tr><td>FINISH</td><td>-</td></tr> </table>		PL	±	PVC	±	PLC	±0.05	PAC	±	PLC	±	PLC	±	ANGLES	±3°	FINISH	-	PRODUCT SPEC - APPLICATION SPEC - WEIGHT -		NAME CONTACT A SOUDER DIL SIZE A3 CAGE CODE 00779 DRAWING NO C-1544169 RESTRICTED TO -	
PL	±																						
PVC	±																						
PLC	±0.05																						
PAC	±																						
PLC	±																						
PLC	±																						
ANGLES	±3°																						
FINISH	-																						
MATERIAL CuSn6P		CUSTOMER DRAWING		SCALE 4.000 SHEET 1 OF 1 REV F																			