

# EFM8 Busy Bee Family

## EFM8BB51 Data Sheet



The EFM8BB51, part of the wide supply 5 Volt Busy Bee family of MCUs, is a multi-purpose line of 8-bit microcontrollers with a comprehensive feature set in small packages.

These devices offer high-value by integrating advanced analog and communication peripherals into small packages, making them ideal for space-constrained applications. With an efficient 8051 core, 5 Volt capable I/O, precision analog, and enhanced pulse-width modulation, the EFM8BB51 family is also optimal for embedded applications.

EFM8BB51 applications include the following:

- LED/Lighting control
- Industrial automation
- Consumer electronics
- Motor control
- Power tools
- Appliances
- Toys
- Personal hygiene products
- Battery packs
- Optical Modules

### KEY FEATURES

- Pipelined 8-bit C8051 core with 50 MHz maximum operating frequency
- 16 multifunction, 5 Volt capable I/O pins
- 1 x 12-bit Analog to Digital converter
- 2 x analog comparators
- Integrated temperature sensor
- 3-channel PCA w/ PWM
- 3-channel PWM engine
- 4 x 16-bit timers
- 2 x 8-bit timers
- 2 x UART
- SMBus/I2C
- SPI with 4 byte FIFO
- Priority crossbar for flexible pin mapping
- 4 x configurable logic units

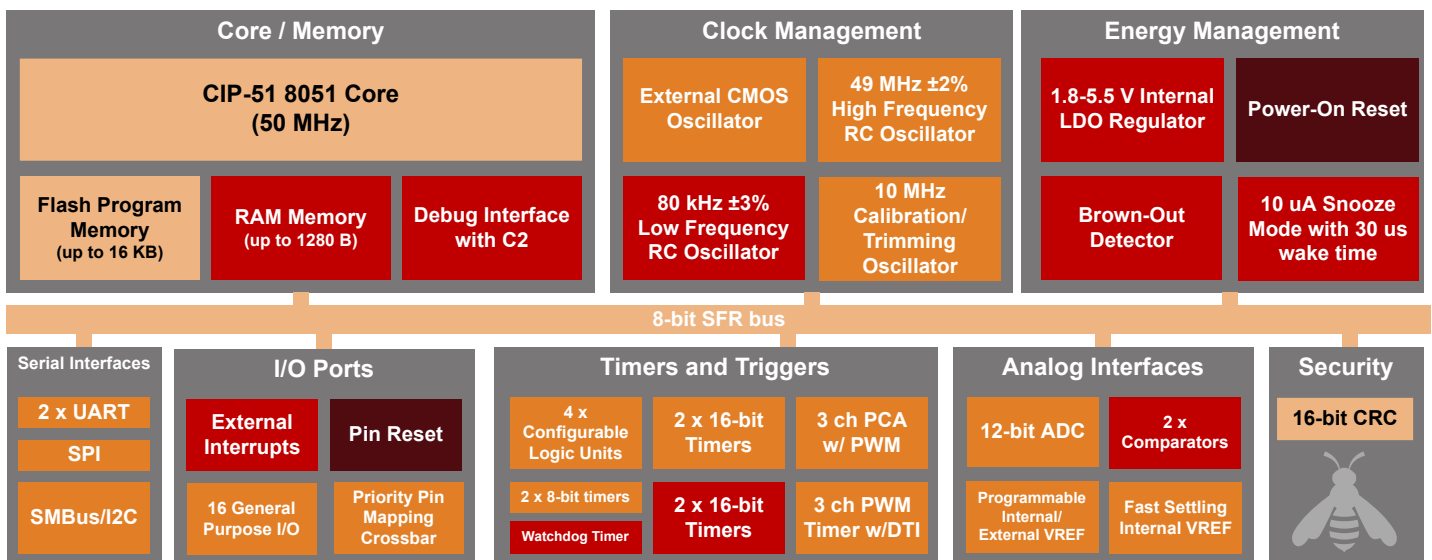

Lowest power mode with peripheral operational:

- Normal
- Idle
- Snooze
- Shutdown

## 1. Feature List

The EFM8BB51 highlighted features are listed below.

- Core:
  - Pipelined CIP-51 Core
  - Fully compatible with standard 8051 instruction set
  - 70% of instructions execute in 1-2 clock cycles
  - 50 MHz maximum operating frequency
- Memory:
  - Up to 16 kB flash memory, in-system re-programmable from firmware.
  - Up to 1280 bytes RAM
- Power:
  - Internal LDO regulator for CPU core voltage
  - Power-on reset circuit and brownout detectors
  - Snooze mode with LFO running, 10  $\mu$ A and 30  $\mu$ s wake
- I/O: 16 total multifunction I/O pins:
  - All pins 5 V capable under bias
  - Flexible peripheral crossbar for peripheral routing
  - High current to allow direct drive of LEDs
- Clock Sources:
  - Internal 49 MHz oscillator with  $\pm$  2% accuracy
  - Internal 80 kHz low-frequency oscillator with  $\pm$  3% accuracy
  - Internal 10 MHz oscillator
  - External CMOS clock option
- On-Chip, Non-Intrusive Debugging
  - Full memory and register inspection
  - Four hardware breakpoints, single-stepping
- Timers/Counters and PWM:
  - 3-channel programmable counter array (PCA) supporting PWM, capture/compare, and frequency output modes
  - 3-channel PWM engine with complementary outputs and dead time insertion (DTI)
  - 2 x 8-bit general-purpose timers
  - 4 x 16-bit general-purpose timers
  - Independent watchdog timer, clocked from the low frequency oscillator
- Communications and Digital Peripherals:
  - 2 x UART up to 3 Mbaud
  - SPI™ Main / Secondary up to 12 Mbps
  - SMBus™/I2C™ Leader / Follower up to 400 kbps
  - 16-bit CRC unit, supporting automatic CRC of flash at 256-byte boundaries
- Analog:
  - 12-bit, 612 ksp/s Analog-to-Digital Converter (ADC) with 16 channels and 11-bit ENOB
  - 2 x Analog comparator with adjustable reference
  - 1.2 - 2.4 V precision VREF routable to external pin
- 4 configurable logic units
- Pre-loaded UART bootloader
- 128-bit unique device identifier (UUID)
- Temperature range -40 to 85 °C or -40 to 125 °C
- Single power supply 1.8 to 5.5 V
- TSSOP20 and QFN20 packages

With on-chip power-on reset, voltage supply monitor, watchdog timer, and clock oscillator, the EFM8BB51 devices are truly standalone system-on-a-chip solutions. The flash memory is reprogrammable in-circuit, providing non-volatile data storage and allowing field upgrades of the firmware. The on-chip debugging interface (C2) allows non-intrusive (uses no on-chip resources), full speed, in-circuit debugging using the production MCU installed in the final application. This debug logic supports inspection and modification of memory and registers, setting breakpoints, single stepping, and run and halt commands. All analog and digital peripherals are fully functional while debugging. Each device is specified for 1.8 to 5.5 V. Devices are offered in 20-pin TSSOP and 20-pin QFN packages. All package options are lead-free and RoHS compliant.

## 2. Ordering Information

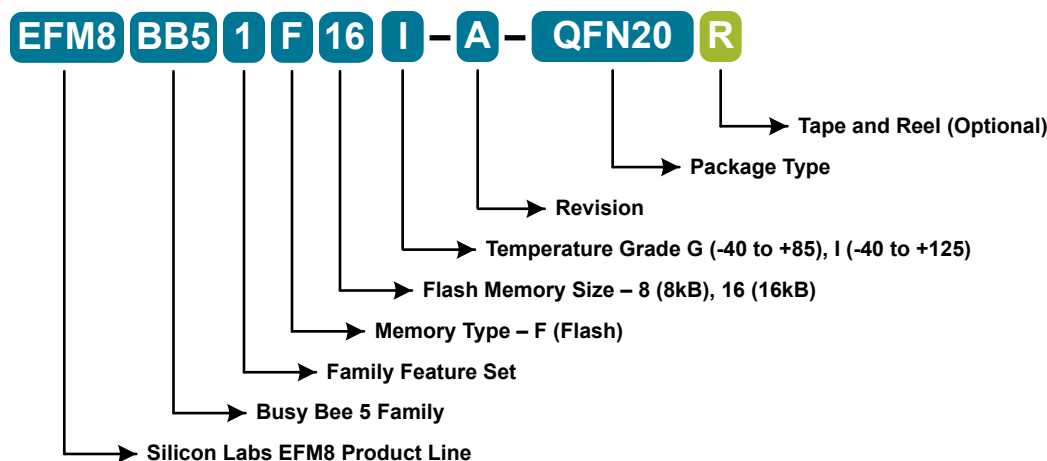

Figure 2.1. EFM8BB51 Part Numbering

All EFM8BB51 family members have the following features:

- CIP-51 Core running up to 50 MHz
- Three Internal Oscillators (49 MHz, 10 MHz, and 80 kHz)
- SMBus / I2C
- SPI
- 2 x UART
- 3-Channel Programmable Counter Array (PWM, Clock Generation, Capture/Compare)
- 3-Channel PWM engine with complementary outputs and dead time insertion
- 4 x 16-bit Timers
- 4 x Configurable Logic
- 2 x Analog Comparator
- 12-bit Analog-to-Digital Converter with integrated multiplexer, voltage reference, and temperature sensor
- 16-bit CRC Unit
- Pre-loaded UART bootloader

In addition to these features, each part number in the EFM8B51 family has a set of features that vary across the product line. The ordering information table shows the features available on each family member.

Table 2.1. Ordering Information

Ordering Code	Flash Memory (kB)	RAM (Bytes)	GPIO	Temperature Range	Package
EFM8BB51F8I-C-TSSOP20	8	1280	16	-40 to 125 °C	TSSOP20
EFM8BB51F8I-C-QFN20	8	1280	16	-40 to 125 °C	QFN20
EFM8BB51F8G-C-TSSOP20	8	1280	16	-40 to 85 °C	TSSOP20
EFM8BB51F8G-C-QFN20	8	1280	16	-40 to 85 °C	QFN20
EFM8BB51F16I-C-TSSOP20	16	1280	16	-40 to 125 °C	TSSOP20
EFM8BB51F16I-C-QFN20	16	1280	16	-40 to 125 °C	QFN20
EFM8BB51F16G-C-TSSOP20	16	1280	16	-40 to 85 °C	TSSOP20
EFM8BB51F16G-C-QFN20	16	1280	16	-40 to 85 °C	QFN20

# Table of Contents

<b>1. Feature List</b>	<b>2</b>
<b>2. Ordering Information</b>	<b>3</b>
<b>3. System Overview</b>	<b>6</b>
3.1 Introduction	6
3.2 CIP-51 Microcontroller Core	7
3.3 Memory	8
3.4 Power	11
3.5 I/O	12
3.6 Clocking	12
3.7 Counters/Timers and PWM	12
3.8 Communications and Other Digital Peripherals	14
3.9 Analog	16
3.10 Reset Sources	16
3.11 Debugging	17
3.12 Bootloader	18
<b>4. Electrical Specifications</b>	<b>20</b>
4.1 Electrical Characteristics	20
4.1.1 Absolute Maximum Ratings	20
4.1.2 General Operating Conditions	20
4.1.3 Supply Current Consumption at 5 V, 25 °C	21
4.1.4 Maximum Supply Current Consumption at 5 V, 125 °C	22
4.1.5 Typical Supply Current Consumption at 3.3 V, 25 °C	23
4.1.6 Typical Supply Current Consumption at 1.8 V, 25 °C	24
4.1.7 Reset and Supply Monitor	25
4.1.8 Wakeup Timing	25
4.1.9 Flash Memory Characteristics	26
4.1.10 High-Frequency Oscillator	26
4.1.11 Low-Frequency Oscillator	26
4.1.12 Fast-Start Oscillator	27
4.1.13 External Clock Input	27
4.1.14 Analog to Digital Converter (ADC)	28
4.1.15 Temperature Sensor	30
4.1.16 Precision Voltage Reference (VREF)	30
4.1.17 Analog Comparators (CMP)	31
4.1.18 General Purpose I/O	32
4.1.19 Configurable Logic	33
4.1.20 SMBus Timing	34
4.1.21 SPI Timing	36
4.2 Typical Performance Curves	38
<b>5. Typical Connection Diagrams</b>	<b>42</b>

5.1 Power . . . . .	.42
5.2 Debug . . . . .	.42
5.3 Other Connections. . . . .	.43
<b>6. Pin Definitions . . . . .</b>	<b>44</b>
6.1 EFM8BB51-QFN20 Pin Definitions . . . . .	.44
6.2 EFM8BB51-TSSOP20 Pin Definitions . . . . .	.48
6.3 Crossbar Functional Map . . . . .	.52
<b>7. QFN20 Package Specifications. . . . .</b>	<b>54</b>
7.1 QFN20 Package Dimensions . . . . .	.54
7.2 QFN20 PCB Land Pattern . . . . .	.56
7.3 QFN20 Package Marking . . . . .	.57
<b>8. TSSOP20 Package Specifications . . . . .</b>	<b>58</b>
8.1 TSSOP20 Package Dimensions . . . . .	.58
8.2 TSSOP20 PCB Land Pattern . . . . .	.60
8.3 TSSOP20 Package Marking . . . . .	.61
<b>9. Revision History . . . . .</b>	<b>62</b>

### 3. System Overview

#### 3.1 Introduction

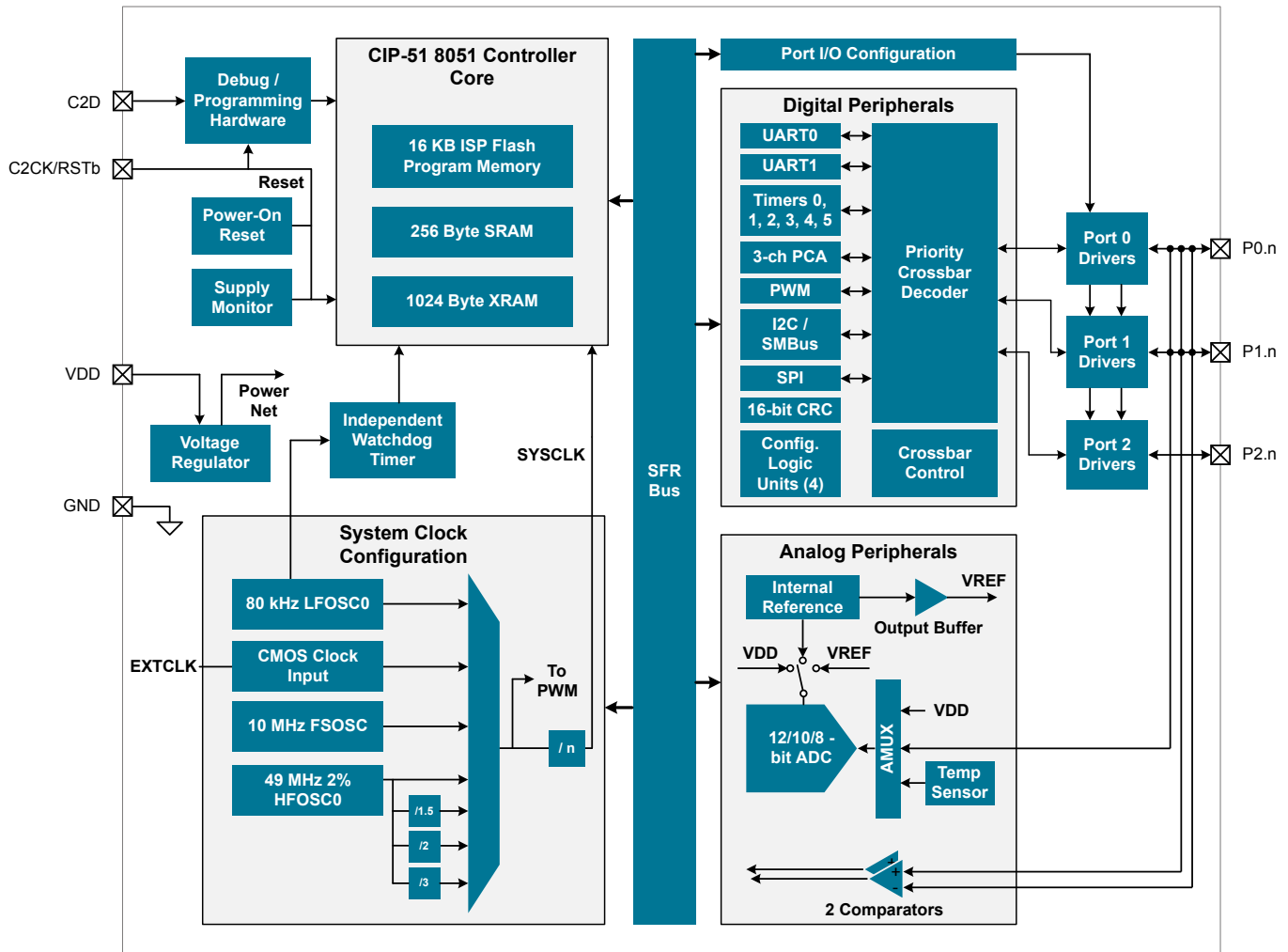

Figure 3.1. Detailed EFM8BB51 Block Diagram

This section describes the EFM8BB51 family at a high level.

For more information on the device packages and pinout, electrical specifications, and typical connection diagrams, see the EFM8BB51 Data Sheet. For more information on each module including register definitions, see the EFM8BB51 Reference Manual. For more information on any errata, see the EFM8BB51 Errata.

### 3.2 CIP-51 Microcontroller Core

The CIP-51 microcontroller core is a high-speed, pipelined, 8-bit core utilizing the standard MCS-51™ instruction set. Any standard 803x/805x assemblers and compilers can be used to develop software. The MCU family has a superset of all the peripherals included with a standard 8051. The CIP-51 includes on-chip debug hardware and interfaces directly with the analog and digital subsystems providing a complete data acquisition or control system solution.

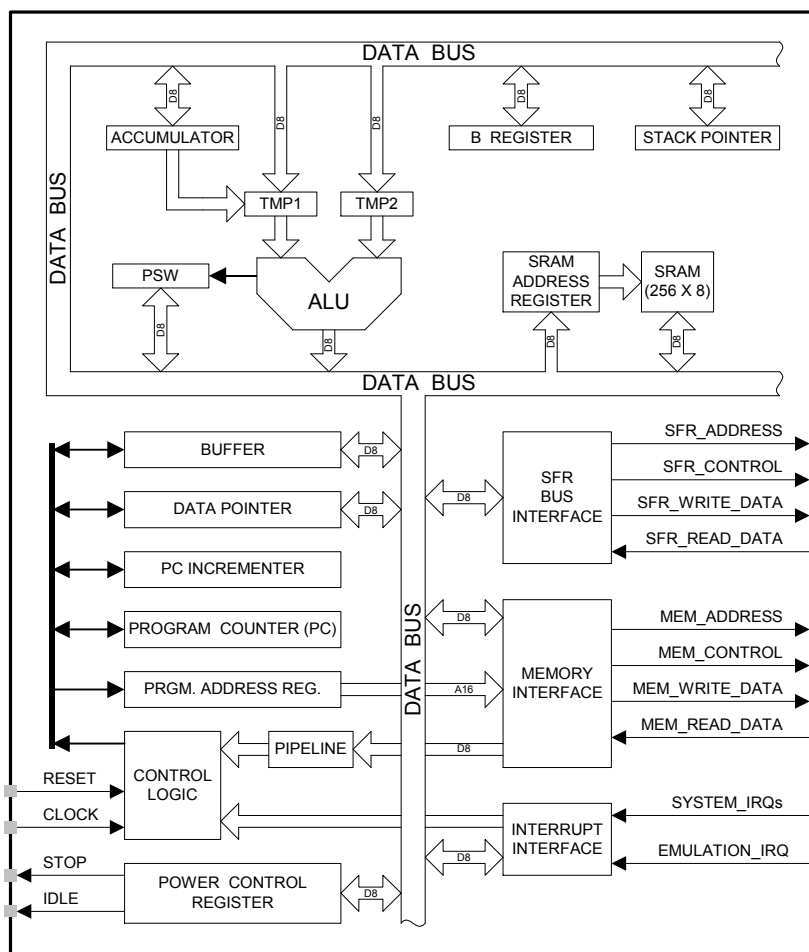

**Figure 3.2. CIP-51 Block Diagram**

The CIP-51 Microcontroller core implements the standard 8051 organization and peripherals as well as additional custom peripherals and functions to extend its capability. The CIP-51 includes the following features:

- Fast, efficient, pipelined architecture.
- Fully compatible with MCS-51 instruction set.
- 0 to 50 MHz operating clock frequency.
- 50 MIPS peak throughput with 50 MHz clock.
- Extended interrupt handler.
- Power management modes.
- On-chip debug logic.
- Program and data memory security.

### 3.3 Memory

The memory organization of the CIP-51 System Controller is similar to that of a standard 8051. There are two separate memory spaces: program memory and data memory. Program and data memory share the same address space but are accessed via different instruction types. Program memory consists of a non-volatile storage area that may be used for either program code or non-volatile data storage. The data memory, consisting of "internal" and "external" data space, is implemented as RAM, and may be used only for data storage. Program execution is not supported from the data memory space.

#### Program Memory

The CIP-51 core has a 64 KB program memory space. The product family implements some of this program memory space as in-system, re-programmable flash memory. Flash security is implemented by a user-programmable location in the flash block and provides read, write, and erase protection. All addresses not specified in the device memory map are reserved and may not be used for code or data storage.

#### Data Memory

The RAM space on the chip includes both an "internal" RAM area which is accessed with MOV instructions, and an on-chip "external" RAM area which is accessed using MOVX instructions. Total RAM varies, based on the specific device. The device memory map has more details about the specific amount of RAM available in each area for the different device variants.



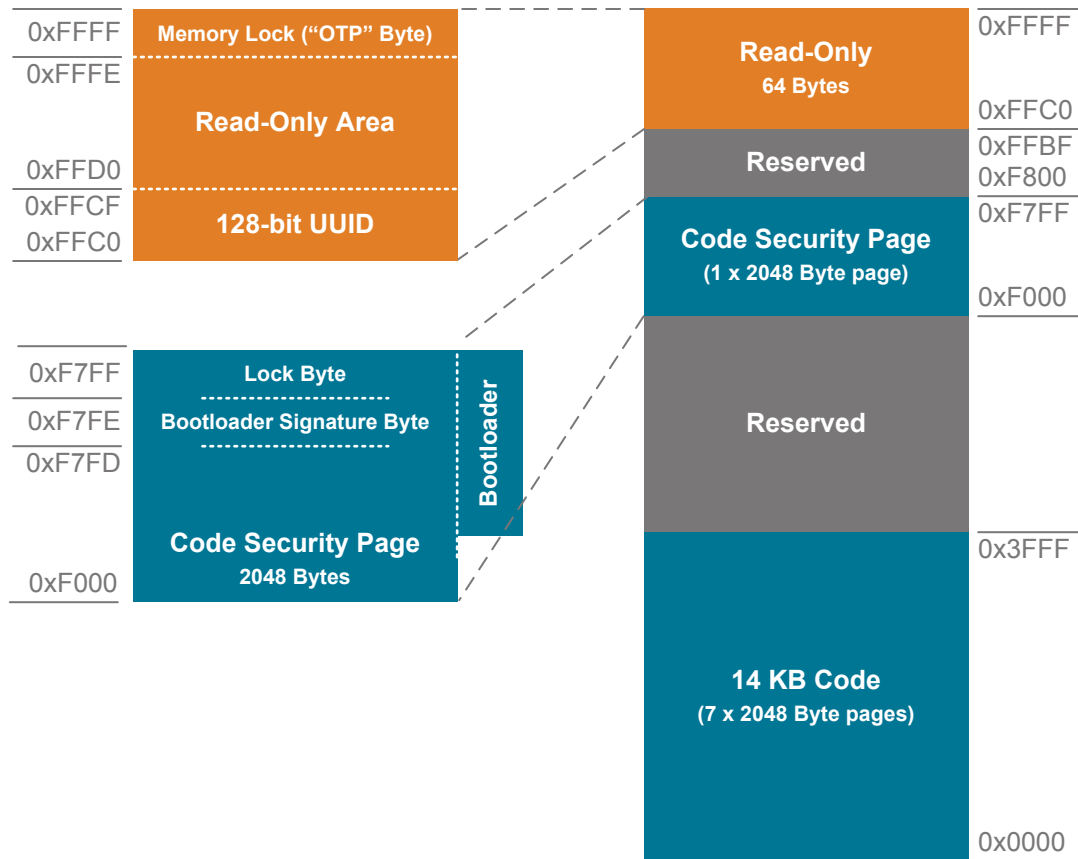

Figure 3.3. Flash Memory Map — 16 KB Devices

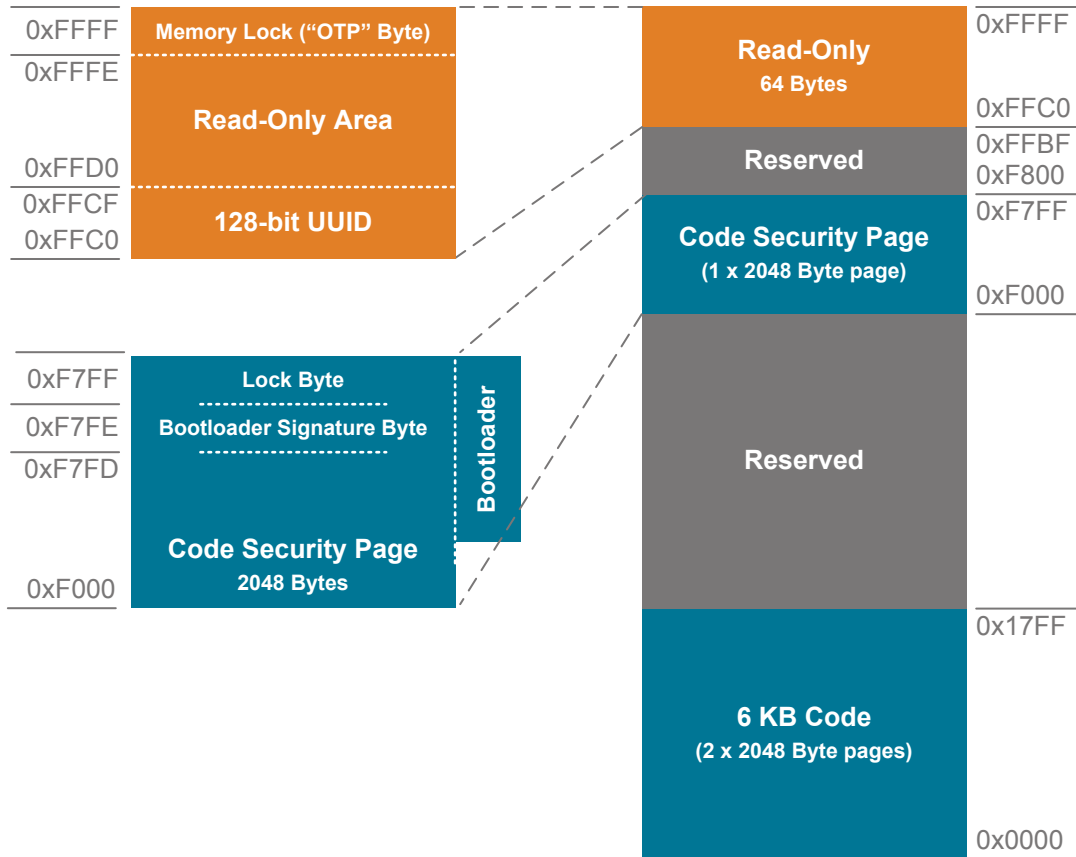

Figure 3.4. Flash Memory Map — 8 KB Devices

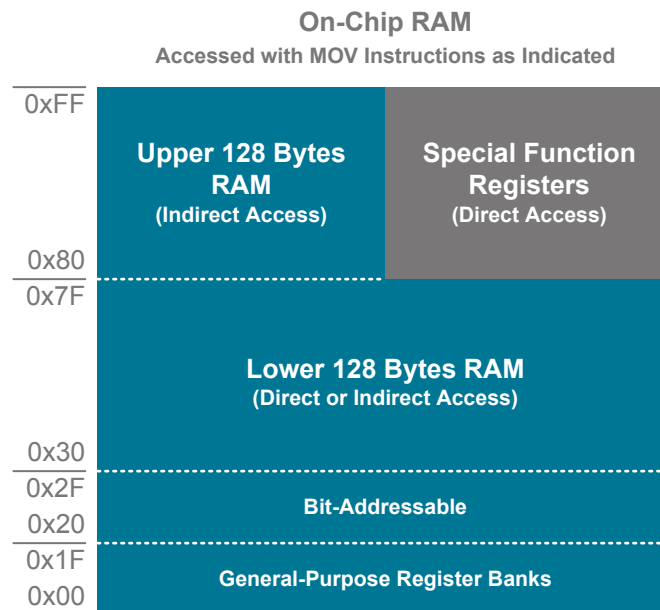
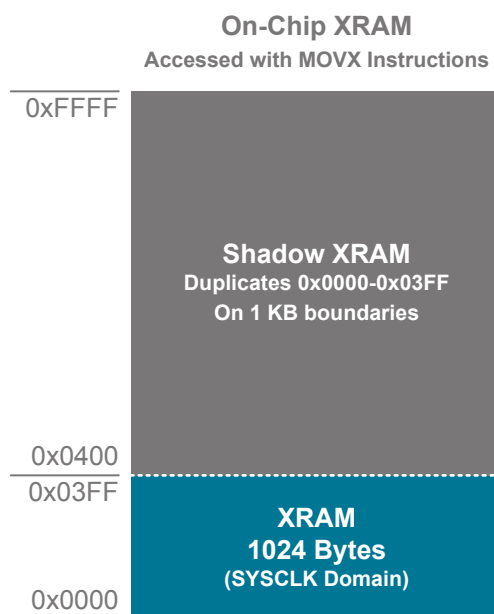

Figure 3.5. Direct / Indirect RAM Memory



**Figure 3.6. XRAM Memory**

### 3.4 Power

All internal circuitry and I/O pins are powered via the VDD supply pin. Most of the internal circuitry is supplied by an on-chip LDO regulator. Control over the device power can be achieved by enabling/disabling individual peripherals as needed. Each analog peripheral can be disabled when not in use and placed in low power mode. Digital peripherals, such as timers and serial buses, have their clocks gated off and draw little power when they are not in use.

**Table 3.1. Power Modes**

Power Mode	Details	Mode Entry	Wake-Up Sources
Normal	Core and all peripherals clocked and fully operational		
Idle	<ul style="list-style-type: none"> <li>Core halted</li> <li>All peripherals clocked and fully operational</li> <li>Code resumes execution on wake event</li> </ul>	Set IDLE bit in PCON0	Any interrupt
Stop	<ul style="list-style-type: none"> <li>HFOSC0 oscillator stopped</li> <li>Pins retain state</li> <li>Exit on any reset source</li> </ul>	<ol style="list-style-type: none"> <li>Clear STOPCF bit in REG0CN</li> <li>Set STOP bit in PCON0</li> </ol>	Any reset source
Snooze	<ul style="list-style-type: none"> <li>Core and peripheral clocks halted</li> <li>HFOSC0 and FSOSC0 oscillators stopped</li> <li>Regulator in low bias current mode for energy savings</li> <li>Timer 3 and 4 may clock from LFOSC0</li> <li>Code resumes execution on wake event</li> </ul>	<ol style="list-style-type: none"> <li>Switch SYSCLK to HFOSC0</li> <li>Set SNOOZE bit in PCON1</li> </ol>	<ul style="list-style-type: none"> <li>Timer 4 Event</li> <li>Port Match Event</li> <li>Comparator 0 Falling Edge</li> <li>CLU Interrupt-Enabled Event</li> </ul>
Shutdown	<ul style="list-style-type: none"> <li>All internal power nets shut down</li> <li>Pins retain state</li> <li>Exit on pin or power-on reset</li> </ul>	<ol style="list-style-type: none"> <li>Set STOPCF bit in REG0CN</li> <li>Set STOP bit in PCON0</li> </ol>	<ul style="list-style-type: none"> <li>RSTb pin reset</li> <li>Power-on reset</li> </ul>

### 3.5 I/O

Digital and analog resources are externally available on the device's multi-purpose I/O pins. Port pins P0.0-P1.6 can be defined as general-purpose I/O (GPIO) or assigned to one of the internal digital resources through the crossbar or dedicated channels. Port pins P0.0-P1.6 can be assigned to an analog function. Port pin P2.0 can be used as GPIO. Additionally, the C2 Interface Data signal (C2D) is shared with P2.0. Not all pins are present in all devices and this is dependent on the chosen device package(s). The pinout differences are covered in the device datasheet.

The port control block offers the following features:

- Up to 16 multi-function I/O pins, supporting digital and analog functions.
- Flexible priority crossbar decoder for digital peripheral assignment.
- Two drive strength settings for each port.
- State retention feature allows pins to retain configuration through most reset sources.
- Two direct-pin interrupt sources with dedicated interrupt vectors (INT0 and INT1).
- Up to 15 direct-pin interrupt sources with shared interrupt vector (Port Match).

### 3.6 Clocking

The CPU core and peripheral subsystem may be clocked by both internal and external oscillator resources. By default, the system clock comes up running from the HFOSC 24.5 MHz output divided by 8 (3.0625 MHz).

The clock control system offers the following features:

- Provides clock to core and peripherals.
- Configurable system clock source:
  - 49 MHz internal oscillator (HFOSC), accurate to  $\pm 2\%$  across process, supply, and temperature corners
  - 10 MHz internal oscillator (FSOSC), fast-startup, low power
  - 80 kHz low-frequency oscillator (LFOSC)
  - CMOS external clock input (EXTCLK)
  - 24.5 MHz clock from HFOSC
  - 24.5 MHz clock from HFOSC divided by 1.5 (16.33 MHz)
  - 2.5 MHz clock from FSOSC
  - 49 MHz clock from HFOSC divided by 1.5 (32.67 MHz)
- Clock divider with eight settings for flexible clock scaling:
  - Divide the selected clock source by 1, 2, 4, 8, 16, 32, 64, or 128

### 3.7 Counters/Timers and PWM

#### Programmable Counter Array (PCA0)

The programmable counter array (PCA) provides multiple channels of enhanced timer and PWM functionality while requiring less CPU intervention than standard counter/timers. The PCA consists of a dedicated 16-bit counter/timer and one 16-bit capture/compare module for each channel. The counter/timer is driven by a programmable timebase that has flexible external and internal clocking options. Each capture/compare module may be configured to operate independently in one of five modes: Edge-Triggered Capture, Software Timer, High-Speed Output, Frequency Output, or Pulse-Width Modulated (PWM) Output. Each capture/compare module has its own associated I/O line (CEXn) which is routed through the crossbar to port I/O when enabled.

- 16-bit time base
- Programmable clock divisor and clock source selection
- Up to three independently-configurable channels
- 8, 9, 10, 11 and 16-bit PWM modes (center or edge-aligned operation)
- Output polarity control
- Frequency output mode
- Capture on rising, falling or any edge
- Compare function for arbitrary waveform generation
- Software timer (internal compare) mode
- Can accept hardware "kill" signal from comparator 0 or comparator 1

## Pulse Width Modulation (PWM) Timer

The PWM module provides three channels of enhanced 16-bit Pulse-Width Modulated (PWM) functionality, with complementary outputs and automatic dead-time insertion (DTI).

The PWM module has the following features:

- 16-bit counter, operable up to 50 MHz with programmable overflow
- Time base of pre-divided SYSCLK, allowing full speed operation while core and other peripherals clocked slower
- Up to three single-ended channels
- Up to six differential channels, consisting of the single-ended and their complementary outputs with programmable dead-time
- Four hardware triggers (TIMER2 and TIMER3 overflow, CLU2 and CLU3 asynchronous output) plus software trigger
- Adjustable hardware dead-time insertion, supports positive and negative dead time
- Edge-aligned or center-aligned operation
- External hardware stop signal from Comparator or CLU channel with configurable defined PWM output state

## Timers (Timer 0, Timer 1, Timer 2, Timer 3, Timer 4, and Timer 5)

Several counter/timers are included in the device: two are 16-bit counter/timers compatible with those found in the standard 8051, and the rest are 16-bit auto-reload timers for timing peripherals or for general purpose use. These timers can be used to measure time intervals, count external events and generate periodic interrupt requests. Timer 0 and Timer 1 are nearly identical and have four primary modes of operation. The other timers offer both 16-bit and split 8-bit timer functionality with auto-reload and capture capabilities.

Timer 0 and Timer 1 include the following features:

- Standard 8051 timers, supporting backwards-compatibility with firmware and hardware.
- Clock sources include SYSCLK, SYSCLK divided by 12, 4, or 48, the External Clock divided by 8, or an external pin.
- 8-bit auto-reload counter/timer mode
- 13-bit counter/timer mode
- 16-bit counter/timer mode
- Dual 8-bit counter/timer mode (Timer 0)

Timer 2, Timer 3, Timer 4, and Timer 5 are 16-bit timers including the following features:

- Clock sources for all timers include SYSCLK, SYSCLK divided by 12, or the External Clock divided by 8
- LFOSC0 divided by 8 may be used to clock Timer 3 and Timer 4 in active or suspend/snooze power modes
- Timer 4 is a low-power wake source, and can be chained together with Timer 3
- 16-bit auto-reload timer mode
- Dual 8-bit auto-reload timer mode
- External pin capture
- LFOSC0 capture
- Comparator 0 capture
- Configurable Logic output capture

## Watchdog Timer (WDT0)

The device includes a programmable watchdog timer (WDT) running off the low-frequency oscillator. A WDT overflow forces the MCU into the reset state. To prevent the reset, the WDT must be restarted by application software before overflow. If the system experiences a software or hardware malfunction preventing the software from restarting the WDT, the WDT overflows and causes a reset. Following a reset, the WDT is automatically enabled and running with the default maximum time interval. If needed, the WDT can be disabled by system software or locked on to prevent accidental disabling. Once locked, the WDT cannot be disabled until the next system reset. The state of the RST pin is unaffected by this reset.

The Watchdog Timer has the following features:

- Programmable timeout interval
- Runs from the low-frequency oscillator
- Lock-out feature to prevent any modification until a system reset

## 3.8 Communications and Other Digital Peripherals

### Universal Asynchronous Receiver/Transmitter (UART0)

UART0 is an asynchronous, full duplex serial port offering modes 1 and 3 of the standard 8051 UART. Enhanced baud rate support allows a wide range of clock sources to generate standard baud rates. Received data buffering allows UART0 to start reception of a second incoming data byte before software has finished reading the previous data byte.

The UART module provides the following features:

- Asynchronous transmissions and receptions.
- Baud rates up to  $\text{SYSCLK}/2$  (transmit) or  $\text{SYSCLK}/8$  (receive).
- 8- or 9-bit data.
- Automatic start and stop generation.
- Single-byte FIFO on transmit and receive.

### Universal Asynchronous Receiver/Transmitter (UART1)

UART1 is an asynchronous, full duplex serial port offering a variety of data formatting options. A dedicated baud rate generator with a 16-bit timer and selectable prescaler is included, which can generate a wide range of baud rates. A received data FIFO allows UART1 to receive multiple bytes before data is lost and an overflow occurs.

UART1 provides the following features:

- Asynchronous transmissions and receptions
- Dedicated baud rate generator supports baud rates up to  $\text{SYSCLK}/2$  (transmit) or  $\text{SYSCLK}/8$  (receive)
- 5, 6, 7, 8, or 9 bit data
- Automatic start and stop generation
- Automatic parity generation and checking
- Single-byte buffer on transmit and receive
- Auto-baud detection
- LIN break and sync field detection
- CTS / RTS hardware flow control

### Serial Peripheral Interface (SPI0)

The serial peripheral interface (SPI) module provides access to a flexible, full-duplex synchronous serial bus. The SPI can operate as a main (clock driver) or secondary (clock receiver) interface in both 3-wire or 4-wire modes, and supports multiple main/secondary devices on a single SPI bus. The chip-select (NSS) signal can be configured as an input to select the SPI in secondary mode, or to disable main mode operation in an environment with multiple main interfaces, avoiding contention on the SPI bus when more than one main device attempts simultaneous data transfers. NSS can also be configured as a firmware-controlled chip-select output in main interface mode, or disabled to reduce the number of pins required. Additional general purpose port I/O pins can be used to select multiple secondary devices.

- Supports 3- or 4-wire main or secondary interface modes
- Supports external clock frequencies up to 12 Mbps in either mode
- Support for all clock phase and polarity modes
- 8-bit programmable clock rate (main)
- Programmable receive timeout (secondary)
- Four byte FIFO on transmit and receive
- Support for multiple main interfaces on the same data lines

## System Management Bus / I2C (SMB0)

The SMBus I/O interface is a two-wire, bi-directional serial bus. The SMBus is compliant with the System Management Bus Specification, version 1.1, and compatible with the I<sup>2</sup>C serial bus.

The SMBus module includes the following features:

- Standard (up to 100 kbps) and Fast (400 kbps) transfer speeds
- Support for leader, follower, and multi-leader modes
- Hardware synchronization and arbitration for multi-leader mode
- Clock low extending (clock stretching) to interface with faster leader devices
- Hardware support for 7-bit follower and general call address recognition
- Firmware support for 10-bit follower address decoding
- Ability to inhibit all follower states
- Programmable data setup/hold times
- Transmit and receive FIFOs (one byte) to help increase throughput in faster applications

## 16-bit CRC (CRC0)

The cyclic redundancy check (CRC) module performs a CRC using a 16-bit polynomial. CRC0 accepts a stream of 8-bit data and posts the 16-bit result to an internal register. In addition to using the CRC block for data manipulation, hardware can automatically CRC the flash contents of the device.

The CRC module is designed to provide hardware calculations for flash memory verification and communications protocols. The CRC module supports the standard CCITT-16 16-bit polynomial (0x1021), and includes the following features:

- Support for CCITT-16 polynomial
- Byte-level bit reversal
- Automatic CRC of flash contents on one or more 256-byte blocks
- Initial seed selection of 0x0000 or 0xFFFF

## Configurable Logic Units (CLU0, CLU1, CLU2, and CLU3)

The Configurable Logic block consists of multiple Configurable Logic Units (CLUs). CLUs are flexible logic functions which may be used for a variety of digital functions, such as replacing system glue logic, aiding in the generation of special waveforms, or synchronizing system event triggers.

- Four configurable logic units (CLUs), with direct-pin and internal logic connections
- Each unit supports 256 different combinatorial logic functions (AND, OR, XOR, muxing, etc.) and includes a clocked flip-flop for synchronous operations
- Units may be operated synchronously or asynchronously
- May be cascaded together to perform more complicated logic functions
- Can operate in conjunction with serial peripherals such as UART and SPI or timing peripherals such as timers and PCA channels
- Can be used to synchronize and trigger multiple on-chip resources (ADC, Timers, etc.)
- Asynchronous output may be used to wake from low-power states

## 3.9 Analog

### 12-Bit Analog-to-Digital Converter (ADC0)

The ADC is a successive-approximation-register (SAR) ADC with 12-bit resolution, integrated track-and hold and a programmable window detector. The ADC is fully configurable under software control via several registers. The ADC may be configured to measure different signals using the analog multiplexer. The voltage reference for the ADC is selectable between internal and external reference sources.

- Up to 12 external inputs
- Single-ended 12-bit, 10-bit and 8-bit modes
- Support for an output update rate of up to 612.5 kcps in 12-bit mode
- Channel sequencer logic with direct-to-XDATA output transfers(Only available if ADCCLK is SYSCLK)
- Asynchronous hardware conversion trigger, selectable between software, internal timer and configurable logic sources
- Output data window comparator allows automatic range checking
- Support for output data accumulation
- Support for conversion complete and window compare interrupts
- Flexible output data formatting
- Includes a fully-internal fast-settling 1.2 - 1.8 V adjustable reference, with support for using the supply as the reference, an external reference, or an on-chip precision 1.2 - 2.4V reference
- Integrated temperature sensor

### Low Current Comparators (CMP0, CMP1)

An analog comparator is used to compare the voltage of two analog inputs, with a digital output indicating which input voltage is higher. External input connections to device I/O pins and internal connections are available through separate multiplexers on the positive and negative inputs. Hysteresis, response time, and current consumption may be programmed to suit the specific needs of the application.

The comparator includes the following features:

- Up to 5 (CMP0) or 4 (CMP1) external positive inputs
- Up to 3 (CMP0) or 3 (CMP1) external negative inputs
- Additional input options:
  - Dedicated 4-bit reference DAC
- Synchronous and asynchronous outputs can be routed to pins via crossbar
- Programmable hysteresis
- Programmable response time
- Interrupts generated on rising, falling, or both edges
- PWM output kill feature
- Wakeup source from snooze mode

## 3.10 Reset Sources

Reset circuitry allows the controller to be easily placed in a predefined default condition. A reset state will be asserted due to low supply voltage, a low state on the external reset pin, or other configurable reset sources. On entry to this reset state, The core halts all execution and sets registers and external pin ports to known initial values. On exit from the reset state, the program counter (PC) is reset and program execution begins at location 0x0000.

Reset sources on the device include the following:

- Power-on reset
- External reset pin
- Comparator reset
- Software-triggered reset
- Supply monitor reset (monitors VDD supply)
- Watchdog timer reset
- Missing clock detector reset
- Flash error reset



### 3.11 Debugging

The EFM8BB51 devices include an on-chip Silicon Labs 2-Wire (C2) debug interface to allow flash programming and in-system debugging with the production part installed in the end application. The C2 interface uses a clock signal (C2CK) and a bi-directional C2 data signal (C2D) to transfer information between the device and a host system. See the C2 Interface Specification for details on the C2 protocol.

### 3.12 Bootloader

All devices come pre-programmed with a UART0 bootloader. This bootloader resides in the code security page, which is the last page of code flash; it can be erased if it is not needed.

The byte before the Lock Byte is the Bootloader Signature Byte. Setting this byte to a value of 0xA5 indicates the presence of the bootloader in the system. Any other value in this location indicates that the bootloader is not present in flash.

When a bootloader is present, the device will jump to the bootloader vector after any reset, allowing the bootloader to run. The bootloader then determines if the device should stay in bootload mode or jump to the reset vector located at 0x0000. When the bootloader is not present, the device will jump to the reset vector of 0x0000 after any reset.

Silicon Labs recommends the bootloader be disabled and the flash memory locked after the production programming step in applications where code security is a concern. More information about the factory bootloader protocol, usage, customization and best practices can be found in *AN945: EFM8 Factory Bootloader User Guide*. Application notes can be found on the Silicon Labs website ([www.silabs.com/8bit-appnotes](http://www.silabs.com/8bit-appnotes)) or within Simplicity Studio by using the [Application Notes] tile.

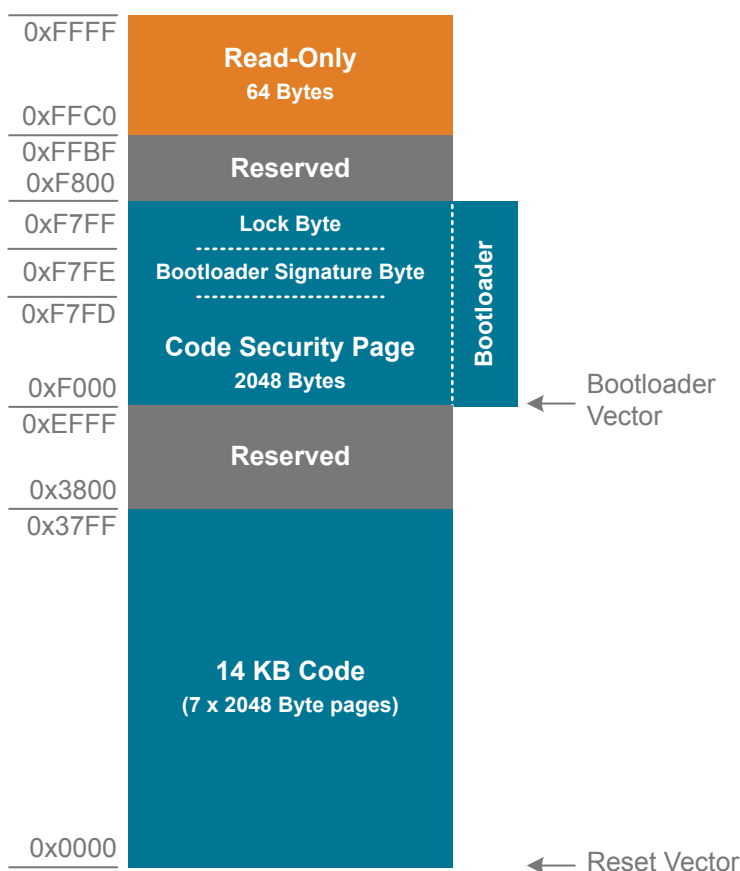

Figure 3.7. Flash Memory Map with Bootloader — 16 KB Devices

Table 3.2. Summary of Pins for Bootloader Communication

Bootloader	Pins for Bootload Communication
UART	TX – P0.4
	RX – P0.5

**Table 3.3. Summary of Pins for Bootload Mode Entry**

Device Package	Pin for Bootload Mode Entry
QFN20 or TSSOP20	P2.0 / C2D

## 4. Electrical Specifications

### 4.1 Electrical Characteristics

All electrical parameters in all tables are specified under the following conditions, unless stated otherwise:

- Typical values are based on  $T_A=25\text{ }^\circ\text{C}$  and all supplies at 3.0 V, by production test and/or technology characterization.
- Minimum and maximum values represent the worst conditions across supply voltage, process variation, and operating temperature, unless stated otherwise.

#### 4.1.1 Absolute Maximum Ratings

Stresses above those listed in [Table 4.1 Absolute Maximum Ratings on page 20](#) may cause permanent damage to the device. This is a stress rating only and functional operation of the devices at those or any other conditions above those indicated in the operation listings of this specification is not implied. Exposure to maximum rating conditions for extended periods may affect device reliability. For more information on the available quality and reliability data, see the Quality and Reliability Monitor Report at <http://www.silabs.com/support/quality/pages/default.aspx>.

**Table 4.1. Absolute Maximum Ratings**

Parameter	Symbol	Test Condition	Min	Typ	Max	Unit
Storage temperature	$T_{STG}$		-50	—	150	$^\circ\text{C}$
Voltage on VDD supply pin	$V_{VDDMAX}$		GND - 0.3	—	5.5	V
Voltage on GPIO pins	$V_{DIGPIN}$		GND - 0.3	—	VDD + 0.3	V
Junction temperature	$T_{JMAX}$	-G grade	—	—	105	$^\circ\text{C}$
		-I grade	—	—	125	$^\circ\text{C}$
Total current into supply pins	$I_{VDDMAX}$	Source	—	—	200	mA
Total current into ground pins	$I_{GNDMAX}$	Sink	—	—	200	mA
Current per I/O pin	$I_{IOMAX}$	Source	—	—	50	mA
		Sink	—	—	50	mA
Current for all I/O pin	$I_{IOALLMAX}$	Source	—	—	200	mA
		Sink	—	—	200	mA

#### 4.1.2 General Operating Conditions

**Table 4.2. General Operating Conditions**

Parameter	Symbol	Test Condition	Min	Typ	Max	Unit
Voltage on VDD supply pin	$V_{VDD}$		1.8	—	5.5	V
System clock frequency	$f_{SYSCLK}$		—	—	50	MHz
Operating ambient temperature	$T_A$	-G grade	-40	—	85	$^\circ\text{C}$
		-I grade	-40	—	125	$^\circ\text{C}$

### 4.1.3 Supply Current Consumption at 5 V, 25 °C

All typical and maximum values specified at 25 °C.

**Table 4.3. Supply Current Consumption at 5 V, 25 °C**

Parameter	Symbol	Test Condition	Min	Typ	Max	Unit
Normal Mode, full code execution	I <sub>NORMAL</sub>	f_SYSCLK = 49 MHz using HFOSC <sup>1</sup>	—	55.5	60	μA/MHz
		f_SYSCLK = 24.5 MHz using HFOSC <sup>1</sup>	—	81	90	μA/MHz
		f_SYSCLK = 1.53 MHz using HFOSC <sup>1</sup>	—	691	810	μA/MHz
		f_SYSCLK = 80 kHz using LFOSC <sup>2</sup>	—	648	830	μA
Idle Mode, core halted with peripherals running	I <sub>IDLE</sub>	f_SYSCLK = 49 MHz using HFOSC <sup>1</sup>	—	44	49	μA/MHz
		f_SYSCLK = 24.5 MHz using HFOSC <sup>1</sup>	—	62	70	μA/MHz
		f_SYSCLK = 1.53 MHz using HFOSC <sup>1</sup>	—	673	800	μA/MHz
		f_SYSCLK = 80 kHz using LFOSC <sup>2</sup>	—	648	830	μA
Snooze Mode, core halted and high-frequency clocks stopped, regulator in low-power state	I <sub>SNOOZE</sub>	LFOSC running at 80 kHz	—	10.9	15.3	μA
		No LFOSC	—	9.8	14.2	μA
Stop Mode, core halted, all clocks stopped, internal regulators on, supply monitor off	I <sub>STOP</sub>		—	930	1150	μA
Shutdown Mode, core halted, all clocks stopped, internal regulators off, supply monitor off	I <sub>SHUTDOWN</sub>		—	1.3	1.8	μA

**Note:**

1. Includes current from internal regulators, supply monitor, and HFOSC
2. Includes current from internal regulators, supply monitor, and LFOSC

#### 4.1.4 Maximum Supply Current Consumption at 5 V, 125 °C

All maximum values specified at 125 °C.

**Table 4.4. Maximum Supply Current Consumption at 5 V, 125 °C**

Parameter	Symbol	Test Condition	Min	Typ	Max	Unit
Normal Mode, full code execution	I <sub>NORMAL</sub>	f_SYSCLK = 49 MHz using HFOSC <sup>1</sup>	—	—	63	µA/MHz
		f_SYSCLK = 24.5 MHz using HFOSC <sup>1</sup>	—	—	95	µA/MHz
		f_SYSCLK = 1.53 MHz using HFOSC <sup>1</sup>	—	—	880	µA/MHz
		f_SYSCLK = 80 kHz using LFOSC <sup>2</sup>	—	—	925	µA
Idle Mode, core halted with peripherals running	I <sub>IDLE</sub>	f_SYSCLK = 49 MHz using HFOSC <sup>1</sup>	—	—	52	µA/MHz
		f_SYSCLK = 24.5 MHz using HFOSC <sup>1</sup>	—	—	75	µA/MHz
		f_SYSCLK = 1.53 MHz using HFOSC <sup>1</sup>	—	—	875	µA/MHz
		f_SYSCLK = 80 kHz using LFOSC <sup>2</sup>	—	—	925	µA
Snooze Mode, core halted and high-frequency clocks stopped, regulator in low-power state	I <sub>SNOOZE</sub>	LFOSC running at 80 kHz	—	—	170	µA
		No LFOSC	—	—	170	µA
Stop Mode, core halted, all clocks stopped, internal regulators on, supply monitor off	I <sub>STOP</sub>		—	—	1250	µA
Shutdown Mode, core halted, all clocks stopped, internal regulators off, supply monitor off	I <sub>SHUTDOWN</sub>		—	—	30	µA
<b>Note:</b> 1. Includes current from internal regulators, supply monitor, and HFOSC 2. Includes current from internal regulators, supply monitor, and LFOSC						

#### 4.1.5 Typical Supply Current Consumption at 3.3 V, 25 °C

All typical values specified at 25 °C.

**Table 4.5. Typical Supply Current Consumption at 3.3 V, 25 °C**

Parameter	Symbol	Test Condition	Min	Typ	Max	Unit
Normal Mode, full code execution	I <sub>NORMAL</sub>	f_SYSCLK = 49 MHz using HFOSC <sup>1</sup>	—	57	—	µA/MHz
		f_SYSCLK = 24.5 MHz using HFOSC <sup>1</sup>	—	82	—	µA/MHz
		f_SYSCLK = 1.53 MHz using HFOSC <sup>1</sup>	—	690	—	µA/MHz
		f_SYSCLK = 80 kHz using LFOSC <sup>2</sup>	—	645	—	µA
Idle Mode, core halted with peripherals running	I <sub>IDLE</sub>	f_SYSCLK = 49 MHz using HFOSC <sup>1</sup>	—	45	—	µA/MHz
		f_SYSCLK = 24.5 MHz using HFOSC <sup>1</sup>	—	63	—	µA/MHz
		f_SYSCLK = 1.53 MHz using HFOSC <sup>1</sup>	—	673	—	µA/MHz
		f_SYSCLK = 80 kHz using LFOSC <sup>2</sup>	—	645	—	µA
Snooze Mode, core halted and high-frequency clocks stopped, regulator in low-power state	I <sub>SNOOZE</sub>	LFOSC running at 80 kHz	—	9.3	—	µA
		No LFOSC	—	8.3	—	µA
Stop Mode, core halted, all clocks stopped, internal regulators on, supply monitor off	I <sub>STOP</sub>		—	924	—	µA
Shutdown Mode, core halted, all clocks stopped, internal regulators off, supply monitor off	I <sub>SHUTDOWN</sub>		—	0.24	—	µA

**Note:**

1. Includes current from internal regulators, supply monitor, and HFOSC
2. Includes current from internal regulators, supply monitor, and LFOSC

#### 4.1.6 Typical Supply Current Consumption at 1.8 V, 25 °C

All typical values specified at 25 °C.

**Table 4.6. Typical Supply Current Consumption at 1.8 V, 25 °C**

Parameter	Symbol	Test Condition	Min	Typ	Max	Unit
Normal Mode, full code execution	I <sub>NORMAL</sub>	f_SYSCLK = 49 MHz using HFOSC <sup>1</sup>	—	56	—	µA/MHz
		f_SYSCLK = 24.5 MHz using HFOSC <sup>1</sup>	—	81	—	µA/MHz
		f_SYSCLK = 1.53 MHz using HFOSC <sup>1</sup>	—	669	—	µA/MHz
		f_SYSCLK = 80 kHz using LFOSC <sup>2</sup>	—	612	—	µA
Idle Mode, core halted with peripherals running	I <sub>IDLE</sub>	f_SYSCLK = 49 MHz using HFOSC <sup>1</sup>	—	45	—	µA/MHz
		f_SYSCLK = 24.5 MHz using HFOSC <sup>1</sup>	—	62	—	µA/MHz
		f_SYSCLK = 1.53 MHz using HFOSC <sup>1</sup>	—	504	—	µA/MHz
		f_SYSCLK = 80 kHz using LFOSC <sup>2</sup>	—	612	—	µA
Snooze Mode, core halted and high-frequency clocks stopped, regulator in low-power state	I <sub>SNOOZE</sub>	LFOSC running at 80 kHz	—	10.0	—	µA
		No LFOSC	—	9.0	—	µA
Stop Mode, core halted, all clocks stopped, internal regulators on, supply monitor off	I <sub>STOP</sub>		—	890	—	µA
Shutdown Mode, core halted, all clocks stopped, internal regulators off, supply monitor off	I <sub>SHUTDOWN</sub>		—	0.19	—	µA

**Note:**

1. Includes current from internal regulators, supply monitor, and HFOSC
2. Includes current from internal regulators, supply monitor, and LFOSC



#### 4.1.7 Reset and Supply Monitor

**Table 4.7. Reset and Supply Monitor**

Parameter	Symbol	Test Condition	Min	Typ	Max	Unit
VDD supply monitor threshold <sup>1</sup>	V <sub>VDDM</sub>	Falling voltage on V <sub>VDD</sub>	1.67	1.71	1.75	V
Power-on reset (POR) threshold	V <sub>POR</sub>	Rising voltage on V <sub>VDD</sub>	—	1.76	1.8	V
Supply ramp rate <sup>1</sup>	RAMP <sub>VDD</sub>		10	—	—	us/V
Reset delay from POR	t <sub>POR</sub>	Relative to V <sub>VDD</sub> > V <sub>POR</sub> , ramp to V <sub>POR</sub> in ≤ 100 μs	—	220	390	μs
Reset delay from non-POR source	t <sub>RST</sub>	Time between release of reset source and code execution	—	100	200	μs
Missing clock detector response time	t <sub>MCD</sub>	Time between final rising edge and reset, F <sub>SYSCLOCK</sub> > 1 MHz	—	0.25	0.38	ms
Missing clock detector trigger frequency	f <sub>MCD</sub>		—	6.5	10	kHz
RSTb low time to generate reset <sup>2</sup>	t <sub>RSTL</sub>		15	—	—	μs

**Note:**

1. V<sub>VDDM</sub> is a parameter that is calibrated and adjusted shortly after reset. The circuit uses the initial, uncalibrated value directly out of any reset. On some devices, the uncalibrated V<sub>VDDM</sub> level may be lower than the calibrated V<sub>VDDM</sub> value, resulting in multiple reset pulses on the RST pin if the supply voltage remains between these two levels.
2. If the device is in Snooze mode when a pin reset occurs, the reset sequence will be initiated by the minimum time specified, but the device may require up to 130 μs to fully complete this reset.

#### 4.1.8 Wakeup Timing

**Table 4.8. Wakeup Timing**

Parameter	Symbol	Test Condition	Min	Typ	Max	Unit
Idle mode wake-up time	t <sub>IDLEWK</sub>	Entered Idle mode running from HFOSC	2	—	3	SYSCLOCKs
		Entered Idle mode running from LFOSC	4	—	5	SYSCLOCKs
Snooze mode wake-up time	t <sub>SNOOZEWK</sub>	SYSCLOCK = HFOSC, CLKDIV = 0x00, System in Snooze when wake event occurs.	—	30	50	μs

#### 4.1.9 Flash Memory Characteristics

Table 4.9. Flash Memory Characteristics

Parameter	Symbol	Test Condition	Min	Typ	Max	Unit
V <sub>VDD</sub> voltage during programming <sup>1</sup>	V <sub>PROG</sub>		2.3	—	5.5	V
Flash supply monitor threshold <sup>1</sup>	V <sub>FMON</sub>		2.3	—	—	V
Write time <sup>2</sup>	t <sub>WRITE</sub>	One byte, F <sub>SYSClk</sub> = 24.5 MHz	66.5	70	73.5	μs
Erase time <sup>2</sup>	t <sub>ERASE</sub>	One page, F <sub>SYSClk</sub> = 24.5 MHz	24.7	26	27.3	μs
Flash erase cycles before failure <sup>3</sup>	EC <sub>FLASH</sub>	T <sub>A</sub> ≤ 125 °C	10k	—	—	cycles
Flash data retention	RET <sub>FLASH</sub>	T <sub>A</sub> ≤ 125 °C	10	—	—	years
CRC calculation time	t <sub>CRC</sub>	Per 256-byte block, SYSClk = 49 MHz	—	5.4	—	μs

**Note:**

1. The flash supply monitor prevents flash programming operations below the minimum safe supply voltage.
2. Does not include sequencing time before and after the write/erase operation, which may be multiple SYSClk cycles.
3. Flash data retention information is published in the Quarterly Quality and Reliability Report.

#### 4.1.10 High-Frequency Oscillator

Table 4.10. High-Frequency Oscillator

Parameter	Symbol	Test Condition	Min	Typ	Max	Unit
HFOSC oscillator frequency	f <sub>HFOSC</sub>		48	49	50	MHz
Power supply sensitivity	PSS <sub>HFOSC</sub>	T <sub>A</sub> = 25 °C	—	0.026	—	%/V
Temperature sensitivity	TS <sub>HFOSC</sub>	V <sub>VDD</sub> = 3.0 V	—	140	—	ppm/°C
HFOSC start-up time	t <sub>STARTUP</sub>		—	3.75	—	μs

#### 4.1.11 Low-Frequency Oscillator

Table 4.11. Low-Frequency Oscillator

Parameter	Symbol	Test Condition	Min	Typ	Max	Unit
LFOSC oscillator frequency	f <sub>LFOSC</sub>		77.6	80	82.4	kHz
Power supply sensitivity	PSS <sub>LFOSC</sub>	T <sub>A</sub> = 25 °C	—	0.08	—	%/V
Temperature sensitivity	TS <sub>LFOSC</sub>	V <sub>VDD</sub> = 3.0 V	—	66	—	ppm/°C
LFOSC start-up time	t <sub>STARTUP</sub>		—	11.1	—	μs

#### 4.1.12 Fast-Start Oscillator

**Table 4.12. Fast-Start Oscillator**

Parameter	Symbol	Test Condition	Min	Typ	Max	Unit
FSOSC oscillator frequency	$f_{\text{FSOSC}}$		9	10	11	MHz
power supply sensitivity	$\text{PSS}_{\text{FSOSC}}$	$T_A = 25\text{ }^\circ\text{C}$	—	0.1	—	%/V
Temperature sensitivity	$\text{TS}_{\text{FSOSC}}$	$V_{\text{VDD}} = 3.0\text{ V}$	—	2000	—	ppm/ $^\circ\text{C}$
FSOSC start-up time	$t_{\text{STARTUP}}$		—	0.48	—	$\mu\text{s}$

#### 4.1.13 External Clock Input

**Table 4.13. External Clock Input**

Parameter	Symbol	Test Condition	Min	Typ	Max	Unit
External clock frequency	$f_{\text{CMOS}}$	Clock provided at EXTCLK pin	0	—	50	MHz
External clock high time	$t_{\text{CMOSH}}$		9	—	—	ns
External clock low time	$t_{\text{CMOSL}}$		9	—	—	ns

#### 4.1.14 Analog to Digital Converter (ADC)

Table 4.14. Analog to Digital Converter (ADC)

Parameter	Symbol	Test Condition	Min	Typ	Max	Unit
Resolution	Resolution	Three resolution settings, 12 bit, 10 bit, and 8 bit	8	—	12	bits
Throughput rate	$f_{\text{SAMPLE}}$	12-bit conversion	—	—	612.5	ksps
		10-bit conversion	—	—	680	ksps
		8-bit conversion	—	—	765	ksps
Conversion time	$t_{\text{CONVERT}}$	12-bit conversion	—	30	—	clocks
		10-bit conversion	—	26	—	clocks
		8-bit conversion	—	22	—	clocks
Required tracking time	$t_{\text{TRACK}}$		400	—	—	ns
SAR clock frequency	$f_{\text{SAR}}$		12.5	—	25	MHz
Power-on time	$t_{\text{PWR}}$		—	—	5	$\mu\text{s}$
Sample/Hold capacitor	$C_{\text{SAR}}$	Gain = 1	—	2	—	pF
		Gain = 0.75	—	1.5	—	pF
		Gain = 0.5	—	1	—	pF
		Gain = 0.25	—	0.5	—	pF
Input mux series impedance	$R_{\text{MUX}}$		—	1.5	—	k $\Omega$
Voltage reference range	$V_{\text{REF}}$	VDD as reference	1.2	—	VDD	V
		External reference via ADC0.VREF	1.2	—	2.5	V
Internal fast-start reference startup time	$t_{\text{FSREF}}$		—	—	5	$\mu\text{s}$
Internal fast-start reference power supply rejection ratio	$\text{PSRR}_{\text{FSREF}}$		—	116	—	ppm/V
Internal fast-start reference voltage	$V_{\text{FSREF}}$	REFSL = 0x2 (1.65 V Setting), VDD $\geq$ 2.2 V	1.61	1.65	1.69	V
		REFSL = 0x1 (1.4 V Setting)	1.36	1.4	1.44	V
		REFSL = 0x0 (1.2 V Setting)	1.17	1.2	1.23	V
		REFSL = 0x3 (1.8 V Setting), VDD $\geq$ 2.2 V	1.75	1.8	1.85	V
Internal fast-start reference temperature coefficient	$\text{TC}_{\text{FSREF}}$		—	66	—	ppm/ $^{\circ}\text{C}$
External voltage reference input current	$I_{\text{EXTVREF}}$	Sample rate = 612.5 ksps	—	5	—	$\mu\text{A}$
Voltage on VDD when used as VREF	$V_{\text{VDDREF}}$	REFSL = 0x4 (VDD * 24/68)	3.4	—	5.5	V
		REFSL = 0x5 (VDD * 34/68)	2.3	—	3.7	V
		REFSL = 0x6 (VDD * 46/68)	1.8	—	2.9	V

Parameter	Symbol	Test Condition	Min	Typ	Max	Unit
Current for VDD divider when VDD used as VREF	$I_{VDDREF}$	REFSL = 0x4, 0x5, or 0x6	—	16	—	$\mu\text{A}$
Input measurement range	$V_{IN}$		—	—	VREF / Gain	V
Maximum voltage at pin	$V_{IN\_MAX}$		—	—	VDD	V
ADC supply current <sup>1</sup>	$I_{ADC}$	Full speed, 612.5 ksp/s, 12-bit conversions	—	250	315	$\mu\text{A}$
Internal fast-start reference supply current	$I_{FSREF}$	1.2 V Setting	—	86	103	$\mu\text{A}$
Integral nonlinearity	INL	12-bit conversion	-2.6	—	1.9	LSB
Differential nonlinearity	DNL	12-bit conversion	-1	—	1.6	LSB
Offset error <sup>2</sup>	$E_{OFFSET}$	12-bit conversion	-3.5	—	2.1	LSB
Full-scale error	$E_{FS}$	12-bit conversion	-3.5	—	2.3	LSB
Effective number of bits	ENOB	Gain = 1, 12-bit conversion <sup>3</sup>	10.8	—	—	bits
Signal-to-Noise	SNR	Gain = 1, 12-bit conversion <sup>3</sup>	67	72	—	dB
Signal-to-Noise Plus Distortion	SNDR	Gain = 1, 12-bit conversion <sup>3</sup>	64	71	—	dB
Total Harmonic Distortion	THD	Gain = 1, 12-bit conversion <sup>3</sup>	—	-74	-64	dB
Spurious-Free Dynamic Range	SFDR	Gain = 1, 12-bit conversion <sup>3</sup>	65	76	—	dB
Power supply rejection ratio	PSRR	At 1 kHz	—	73	—	dB
<p><b>Note:</b></p> <ol style="list-style-type: none"> <li>Does not include current from analog mux charge-pump.</li> <li>Offset is specified using curve fitting and measured using a linear search where the intercept is always positive.</li> <li>Input is 10 kHz sine wave, 1 dB below full scale. ADC using external VREF and AGND pin and sampling at full speed.</li> </ol>						

#### 4.1.15 Temperature Sensor

Table 4.15. Temperature Sensor

Parameter	Symbol	Test Condition	Min	Typ	Max	Unit
Start-up time	$t_{TSENSE}$		—	4	6	$\mu s$
Offset voltage	$V_{OFF\_TSENSE}$	$T_A = 0\text{ }^\circ C$	—	883	—	mV
Offset error <sup>1</sup>	$E_{OFF\_TSENSE}$	$T_A = 0\text{ }^\circ C$	—	20	—	mV
Nominal slope	$M_{TSENSE}$		—	2.95	—	mV/ $^\circ C$
Slope error <sup>1</sup>	$E_{M\_TSENSE}$		-200	—	200	$\mu V/^\circ C$
Supply current	$I_{TSENSE}$		—	50	60	$\mu A$
Linearity	$LIN_{TSENSE}$		—	1.5	—	$^\circ C$
Total error <sup>2</sup>	$E_{TOT\_TSENSE}$		-7.5	—	7.5	$^\circ C$

**Note:**

1. Represents one standard deviation from the mean.
2. The temp sensor error includes the offset error, slope error, and linearity error. The values are based upon characterization and are not tested across temperature in production. The values represent three standard deviations above and below the mean.

#### 4.1.16 Precision Voltage Reference (VREF)

Table 4.16. Precision Voltage Reference (VREF)

Parameter	Symbol	Test Condition	Min	Typ	Max	Unit
Output voltage at VREF pin	$V_{VREFP}$	1.2 V setting, full temperature range, $V_{DD} \geq 1.8\text{ V}$	1.18	1.2	1.22	V
		1.65 V setting, full temperature range, $V_{DD} \geq 1.95\text{ V}$	1.62	1.65	1.67	V
		1.8 V setting, full temperature range, $V_{DD} \geq 2.1\text{ V}$	1.77	1.8	1.83	V
		2.4 V setting, full temperature range, $V_{DD} \geq 2.7\text{ V}$	2.36	2.4	2.43	V
Turn-on time	$t_{VREFP}$	0.1 $\mu F$ bypass on VREF pin, Settling to 8 LSB12	—	110	—	$\mu s$
Temperature coefficient	$TC_{VREFP}$		—	75	—	ppm/ $^\circ C$
Load regulation	$LR_{VREFP}$	2.4 V setting, Load = 0 to 1 mA, sourced	—	4.5	—	$\mu V/\mu A$
Bypass capacitor	$C_{VREFP}$		0.1	—	—	$\mu F$
Supply current	$I_{VREFP}$	Does not include load	—	55	67	$\mu A$
Short-circuit current	$ISC_{VREFP}$		—	—	14.1	mA
Power supply rejection ratio	$PSRR_{VREFP}$		—	64	—	dB

#### 4.1.17 Analog Comparators (CMP)

Table 4.17. Analog Comparators (CMP)

Parameter	Symbol	Test Condition	Min	Typ	Max	Unit
Input pin voltage	$V_{IN}$		0	—	VDD	V
Response time	$t_{RESP}$	CPMD = 0 (highest speed and power), 100 mV differential	—	171	—	ns
		CPMD = 3 (lowest speed and power), 100 mV differential	—	1.82	—	$\mu$ s
Positive Hysteresis	HYS <sub>POS</sub>	CPHYP = 0	—	0	—	mV
		CPHYP = 1	—	12	—	mV
		CPHYP = 2	—	24	—	mV
		CPHYP = 3	—	51	—	mV
Negative Hysteresis	HYS <sub>NEG</sub>	CPHYN = 0	—	0	—	mV
		CPHYN = 1	—	12	—	mV
		CPHYN = 2	—	24	—	mV
		CPHYN = 3	—	51	—	mV
Input pin capacitance	$C_{IN}$		—	2.8	—	pF
Input offset voltage	$V_{OFF}$	CPMD = 0, 25 °C	-10	1.7	10	mV
Input offset temperature coefficient	$TC_{OFF}$		—	0.026	—	mV/°C
Common mode rejection ratio	CMRR		—	69	—	dB
Power supply rejection ratio	PSRR		—	83	—	dB
Comparator supply current <sup>1</sup>	$I_{CMP}$	CPMD = 0	—	7.4	—	$\mu$ A
		CPMD = 1	—	3.9	—	$\mu$ A
		CPMD = 2	—	2.3	—	$\mu$ A
		CPMD = 3	—	0.5	—	$\mu$ A
Internal comparator reference DAC resolution	$N_{CMPREF}$		—	—	4	bits
Comparator reference impedance <sup>2</sup>	$R_{CMPREF}$		—	960	—	k $\Omega$

**Note:**

- Does not include current from analog mux charge-pump.
- The comparator reference impedance is the total resistance of the reference DAC ladder between VDD and GND. Supply current increase when the reference is used is equal to the supply voltage divided by this resistance.

4.1.18 General Purpose I/O

Table 4.18. General Purpose I/O

Parameter	Symbol	Test Condition	Min	Typ	Max	Unit
Output high voltage	V <sub>OH</sub>	High drive, I <sub>OH</sub> = -10 mA, VDD ≥ 3.0 V	VDD - 0.6	—	—	V
		High drive, I <sub>OH</sub> = -9 mA, 2.2 ≤ VDD < 3.0 V	0.8 * VDD	—	—	V
		High drive, I <sub>OH</sub> = -6 mA, VDD < 2.2 V	0.8 * VDD	—	—	V
		Low drive, I <sub>OH</sub> = -3 mA, VDD ≥ 3.0 V	VDD - 0.6	—	—	V
		Low drive, I <sub>OH</sub> = -2.5 mA, 2.2 ≤ VDD < 3.0 V	0.8 * VDD	—	—	V
		Low drive, I <sub>OH</sub> = -2 mA, VDD < 2.2 V	0.8 * VDD	—	—	V
Output low voltage	V <sub>OL</sub>	High drive, I <sub>OL</sub> = 10 mA, VDD ≥ 3.0 V	—	—	0.6	V
		High drive, I <sub>OL</sub> = 8 mA, 2.2 ≤ VDD < 3.0 V	—	—	0.2 * VDD	V
		High drive, I <sub>OL</sub> = 5 mA, VDD < 2.2 V	—	—	0.2 * VDD	V
		Low drive, I <sub>OL</sub> = 3 mA, VDD ≥ 3.0 V	—	—	0.6	V
		Low drive, I <sub>OL</sub> = 2.5 mA, 2.2 ≤ VDD < 3.0 V	—	—	0.2 * VDD	V
		Low drive, I <sub>OL</sub> = 2 mA, VDD < 2.2 V	—	—	0.2 * VDD	V
Input high voltage	V <sub>IH</sub>		0.7 * VDD	—	—	V
Input low voltage	V <sub>IL</sub>		—	—	0.3 * VDD	V
Pin capacitance	C <sub>IO</sub>		—	2	—	pF
Pull-up resistance	R <sub>PU</sub>		70	130	220	kΩ
Input leakage (pull-up disabled or analog mode)	I <sub>LK</sub>		—	0.01	2	μA



4.1.19 Configurable Logic

Table 4.19. Configurable Logic

Parameter	Symbol	Test Condition	Min	Typ	Max	Unit
Propagation delay	$t_{DLY}$	Single CLU, external pin connections	—	—	53	ns
		Single CLU, internal connections	—	3.6	6.3	ns
Clocking frequency	$f_{CLK}$	1, 2, or 3 CLUs cascaded	—	—	50	MHz
		4 CLUs cascaded	—	—	45	MHz

#### 4.1.20 SMBus Timing

**Table 4.20. SMBus Leader Timing Standard Mode (100 kHz class)**

Parameter	Symbol	Test Condition	Min	Typ	Max	Unit
I2C operating frequency <sup>1</sup>	f <sub>I2C</sub>		0	—	70	kHz
SMBus operating frequency <sup>2, 1</sup>	f <sub>SMB</sub>		40	—	70	kHz
SCL clock low time	t <sub>LOW</sub>		4.7	—	—	μs
SCL clock high time <sup>3</sup>	t <sub>HIGH</sub>		9.4	—	50	μs
SDA set-up time <sup>4</sup>	t <sub>SU_DAT</sub>		300	—	—	ns
SDA hold time <sup>4</sup>	t <sub>HD_DAT</sub>		275	—	—	ns
Repeated START condition set-up time	t <sub>SU_STA</sub>		9.4	—	—	μs
Repeated START condition hold time	t <sub>HD_STA</sub>		4.7	—	—	μs
STOP condition set-up time	t <sub>SU_STO</sub>		9.4	—	—	μs
Bus free time between a STOP and START condition	t <sub>BUF</sub>		9.4	—	—	μs
Detect clock low timeout	t <sub>TIMEOUT</sub>		25	—	—	ms

**Note:**

1. The maximum I2C and SMBus frequencies are limited by the minimum Clock Low Period requirements of their respective specifications.
2. The minimum SMBus frequency is limited by the maximum Clock High Period requirement of the SMBus specification.
3. SMBus has a maximum requirement of 50 μs for Clock High Period. Operating frequencies lower than 40 kHz will be longer than 50 μs. I2C can support periods longer than 50 μs.
4. Data setup and hold timing at 40 MHz or lower with EXTHOLD set to 1. The DLYEXT bit can be used to adjust the data setup and hold times.

**Table 4.21. SMBus Leader Timing Fast Mode (400 kHz class)**

Parameter	Symbol	Test Condition	Min	Typ	Max	Unit
I2C operating frequency <sup>1</sup>	f <sub>I2C</sub>		0	—	256	kHz
SMBus operating frequency <sup>2, 1</sup>	f <sub>SMB</sub>		40	—	256	kHz
SCL clock low time	t <sub>LOW</sub>		1.3	—	—	μs
SCL clock high time <sup>3</sup>	t <sub>HIGH</sub>		2.6	—	50	μs
SDA set-up time <sup>4</sup>	t <sub>SU_DAT</sub>		300	—	—	ns
SDA hold time <sup>4</sup>	t <sub>HD_DAT</sub>		275	—	—	ns
Repeated START condition set-up time	t <sub>SU_STA</sub>		2.6	—	—	μs
Repeated START condition hold time	t <sub>HD_STA</sub>		1.3	—	—	μs

Parameter	Symbol	Test Condition	Min	Typ	Max	Unit
STOP condition set-up time	$t_{SU\_STO}$		2.6	—	—	$\mu\text{s}$
Bus free time between a STOP and START condition	$t_{BUF}$		2.6	—	—	$\mu\text{s}$
Detect clock low timeout	$t_{TIMEOUT}$		25	—	—	ms

**Note:**

1. The maximum I2C and SMBus frequencies are limited by the minimum Clock Low Period requirements of their respective specifications.
2. The minimum SMBus frequency is limited by the maximum Clock High Period requirement of the SMBus specification.
3. SMBus has a maximum requirement of 50  $\mu\text{s}$  for Clock High Period. Operating frequencies lower than 40 kHz will be longer than 50  $\mu\text{s}$ . I2C can support periods longer than 50  $\mu\text{s}$ .
4. Data setup and hold timing at 40 MHz or lower with EXTHOLD set to 1. The DLYEXT bit can be used to adjust the data setup and hold times.

**Table 4.22. SMBus Peripheral Timing Generation Formulas**

Parameter	Symbol	Clocks
SMBus / I2C operating frequency	$f_{SMB}$ $f_{I2C}$	$f_{CSO} / 3$
Bus free time between a STOP and START condition	$t_{BUF}$	$2 / f_{CSO}$
Repeated START condition hold time	$t_{HD\_STA}$	$1 / f_{CSO}$
Repeated START condition set-up time	$t_{SU\_STA}$	$2 / f_{CSO}$
STOP condition set-up time	$t_{SU\_STO}$	$2 / f_{CSO}$
SCL clock low time	$t_{LOW}$	$1 / f_{CSO}$
SCL clock high time	$t_{HIGH}$	$2 / f_{CSO}$

**Note:**

1.  $f_{CSO}$  is the SMBus peripheral clock source overflow frequency.

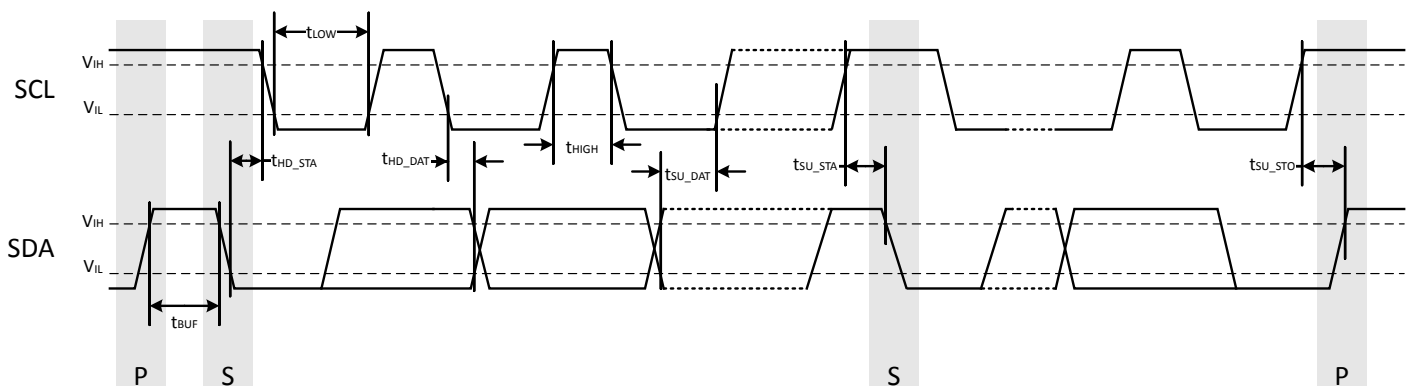

**Figure 4.1. SMBus Peripheral Timing Diagram**

### 4.1.21 SPI Timing

**Table 4.23. SPI Main Timing**

Parameter	Symbol	Test Condition	Min	Typ	Max	Unit
SCLK period <sup>1 2 3</sup>	$t_{SCLK}$	SCLK is derived from SYSCLK, with the fastest possible option being $2 * t_{SYSCLK}$ . The generated SCLK period should not be faster than the specified minimum.	80	—	—	ns
SCLK to MOSI <sup>1 2</sup>	$t_{SCLK\_MO}$		-2.5	—	4.5	ns
MISO setup time <sup>1 2</sup>	$t_{SU\_MI}$		6	—	—	ns
MISO hold time <sup>1 2</sup>	$t_{H\_MI}$		20	—	—	ns

**Note:**

1. Applies for both CKPHA = 0 and CKPHA = 1
2. Measurement performed with 5-10 pF loading on output pins at 10% and 90% of  $V_{DD}$ . Assumed transition timing on input pins is 5.5 ns.
3.  $t_{SYSCLK}$  is one period of the selected SYSCLK.

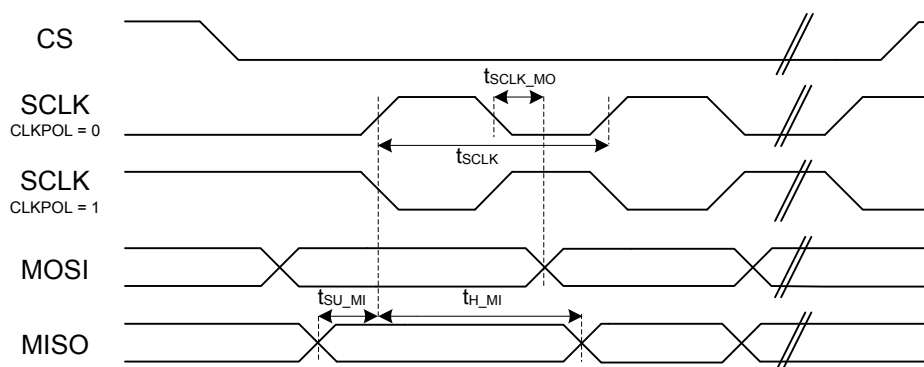

**Figure 4.2. SPI Main Timing**

**Table 4.24. SPI Secondary Timing with 3.0 to 5.5 V supply**

Parameter	Symbol	Test Condition	Min	Typ	Max	Unit
SCLK period <sup>1 2 3</sup>	$t_{SCLK}$		80	—	—	ns
SCLK high time <sup>1 2 3</sup>	$t_{SCLK\_HI}$		40	—	—	ns
SCLK low time <sup>1 2 3</sup>	$t_{SCLK\_LO}$		40	—	—	ns
CS active to MISO <sup>1 2</sup>	$t_{CS\_ACT\_MI}$		24	—	28	ns
CS disable to MISO <sup>1 2</sup>	$t_{CS\_DIS\_MI}$		14	—	18	ns
MOSI setup time <sup>1 2</sup>	$t_{SU\_MO}$		12	—	—	ns
MOSI hold time <sup>1 2 3</sup>	$t_{H\_MO}$		10	—	—	ns

Parameter	Symbol	Test Condition	Min	Typ	Max	Unit
SCLK to MISO <sup>1 2 3</sup>	$t_{\text{SCLK\_MI}}$		17	—	34	ns

**Note:**

1. Applies for both CKPHA = 0 and CKPHA = 1.
2. Measurement performed with 5-10 pF loading on output pins at 10% and 90% of  $V_{\text{VDD}}$ . Assumed transition timing on input pins is 5.5 ns.
3.  $t_{\text{SYSCLK}}$  is one period of the selected SYSCLK.

**Table 4.25. SPI Secondary Timing with 1.8 to 3.0 V supply**

Parameter	Symbol	Test Condition	Min	Typ	Max	Unit
SCLK period <sup>1 2 3</sup>	$t_{\text{SCLK}}$		120	—	—	ns
SCLK high time <sup>1 2 3</sup>	$t_{\text{SCLK\_HI}}$		60	—	—	ns
SCLK low time <sup>1 2 3</sup>	$t_{\text{SCLK\_LO}}$		60	—	—	ns
CS active to MISO <sup>1 2</sup>	$t_{\text{CS\_ACT\_MI}}$		37	—	41	ns
CS disable to MISO <sup>1 2</sup>	$t_{\text{CS\_DIS\_MI}}$		18	—	21	ns
MOSI setup time <sup>1 2</sup>	$t_{\text{SU\_MO}}$		16	—	—	ns
MOSI hold time <sup>1 2 3</sup>	$t_{\text{H\_MO}}$		13	—	—	ns
SCLK to MISO <sup>1 2 3</sup>	$t_{\text{SCLK\_MI}}$		20	—	55	ns

**Note:**

1. Applies for both CKPHA = 0 and CKPHA = 1.
2. Measurement performed with 5-10 pF loading on output pins at 10% and 90% of  $V_{\text{VDD}}$ . Assumed transition timing on input pins is 5.5 ns.
3.  $t_{\text{SYSCLK}}$  is one period of the selected SYSCLK.

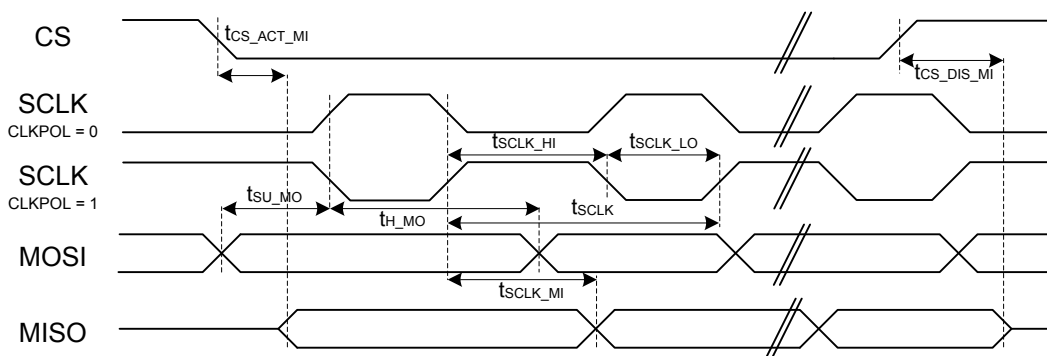

**Figure 4.3. SPI Secondary Timing**

4.2 Typical Performance Curves

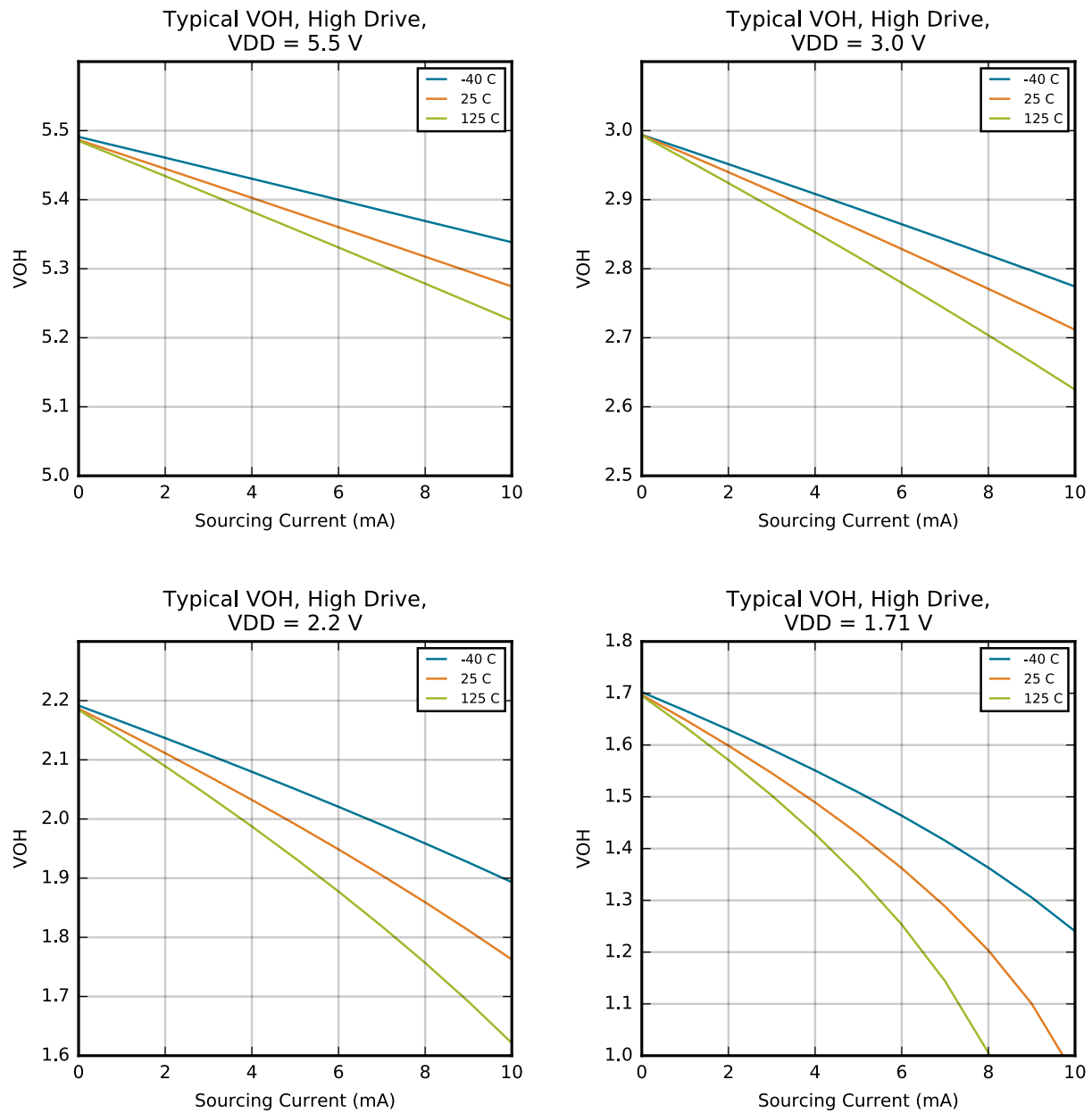

Figure 4.4. Typical  $V_{OH}$  vs. Load, High Drive

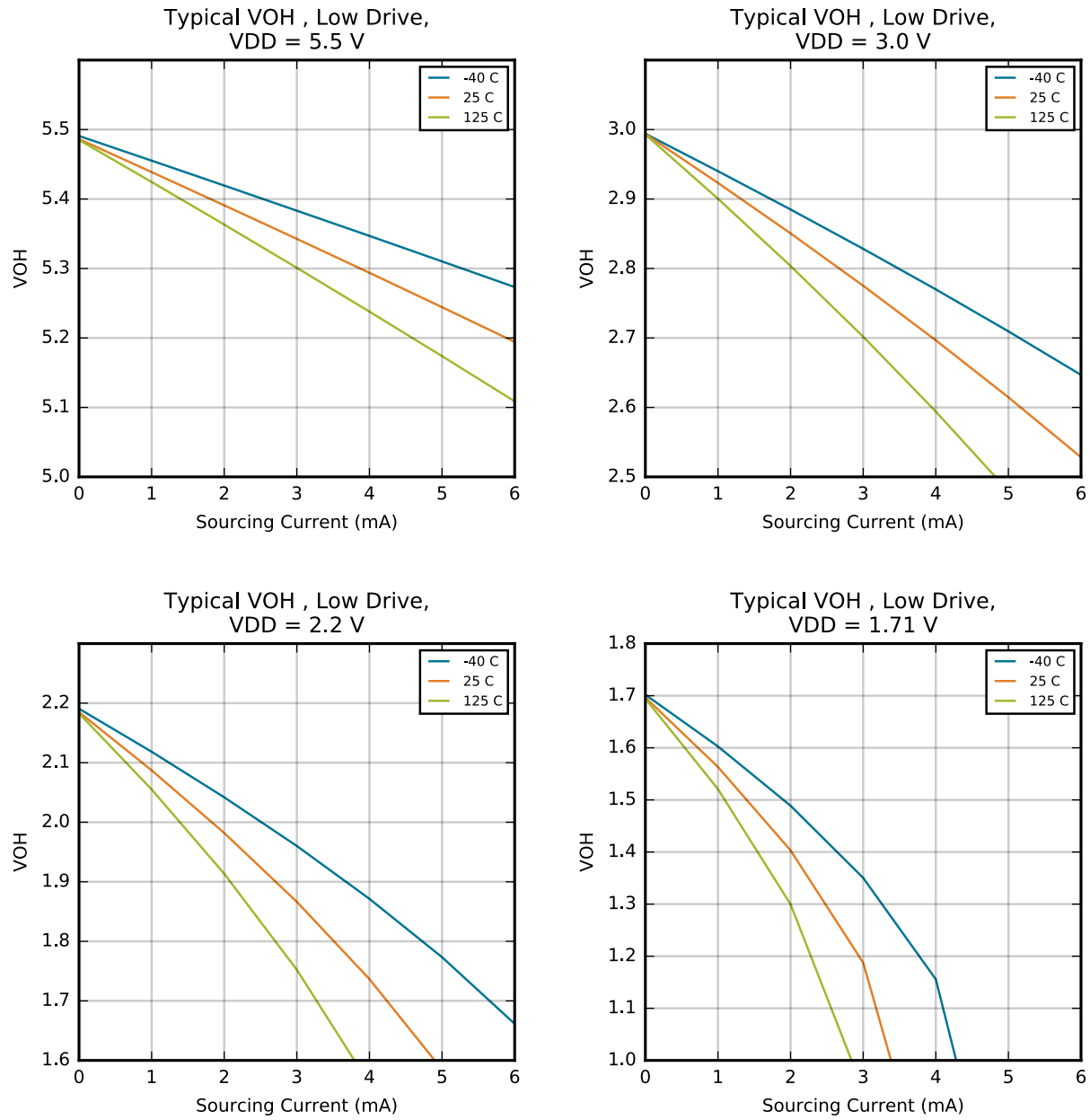

Figure 4.5. Typical VOH vs. Load, Low Drive

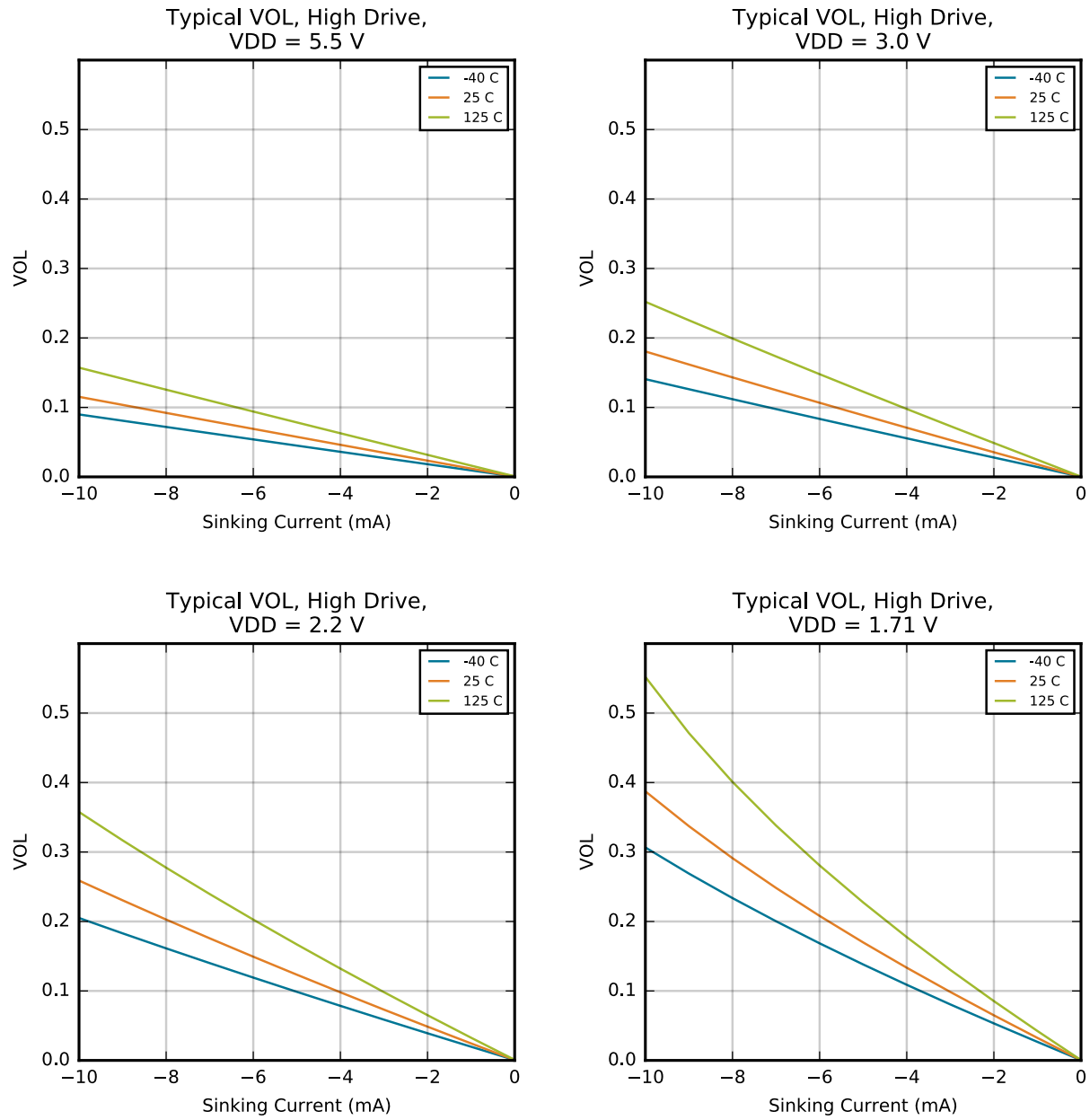

Figure 4.6. Typical VOL vs. Load, High Drive



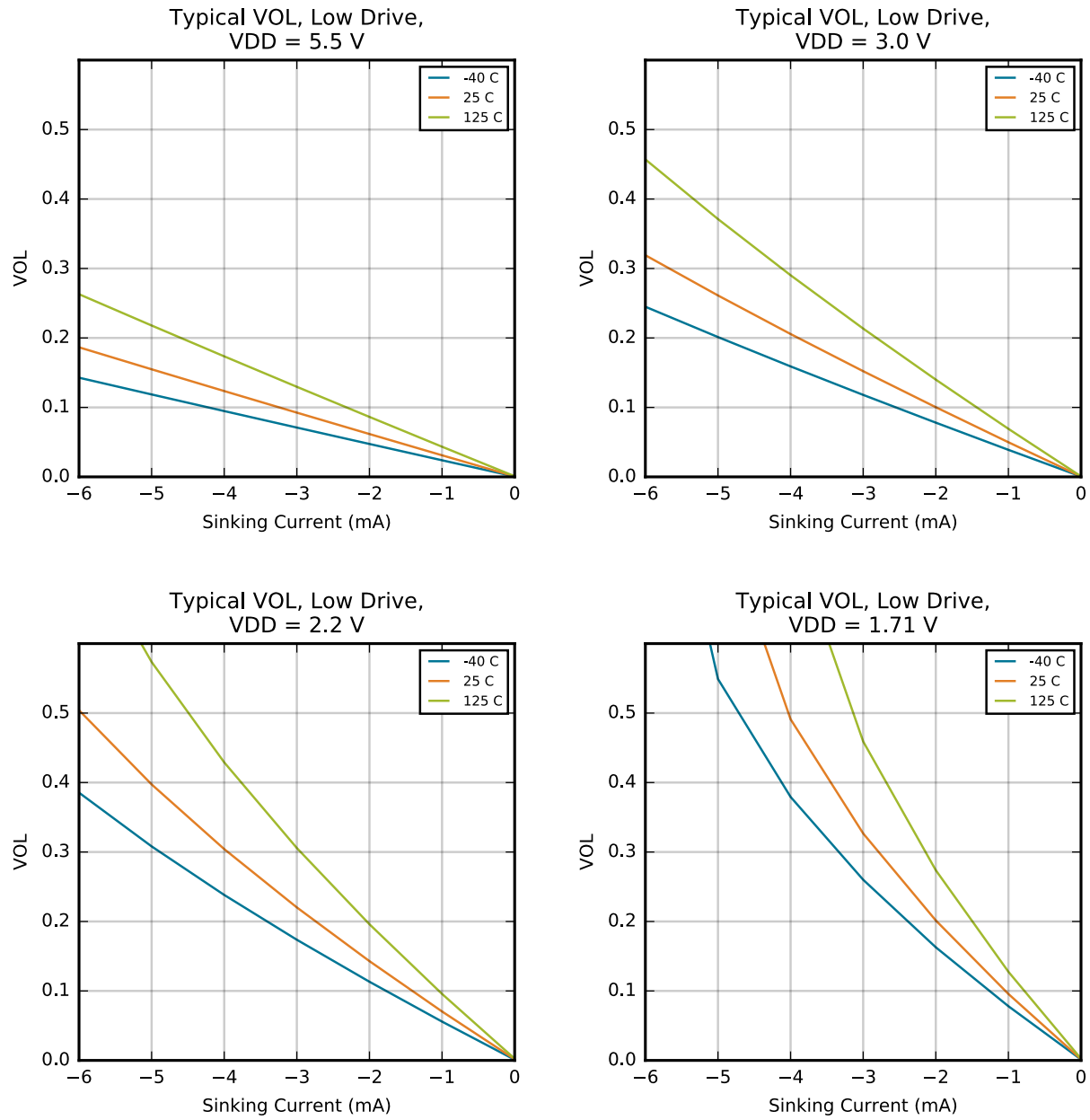

Figure 4.7. Typical VOL vs. Load, Low Drive

## 5. Typical Connection Diagrams

### 5.1 Power

Figure 5.1 Power Connection Diagram on page 42 shows a typical connection diagram for the power pins of the EFM8BB51 devices.

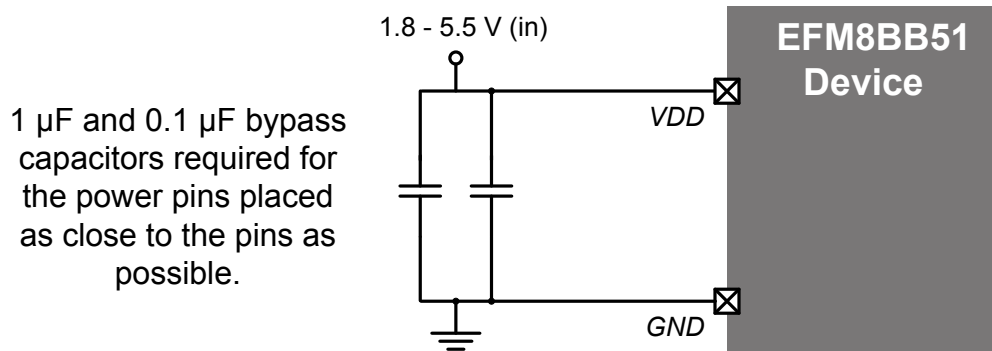

Figure 5.1. Power Connection Diagram

### 5.2 Debug

The diagram below shows a typical connection diagram for the debug connections pins. The pin sharing resistors are only required if the functionality on the C2D (a GPIO pin) and the C2CK (RSTb) is routed to external circuitry. For example, if the RSTb pin is connected to an external switch with debouncing filter or if the GPIO sharing with the C2D pin is connected to an external circuit, the pin sharing resistors and connections to the debug adapter must be placed on the hardware. Otherwise, these components and connections can be omitted.

For more information on debug connections, see the example schematics and information available in application note, *AN124: Pin Sharing Techniques for the C2 Interface*. Application notes can be found on the Silicon Labs website (<http://www.silabs.com/8bit-app-notes>) or in Simplicity Studio.

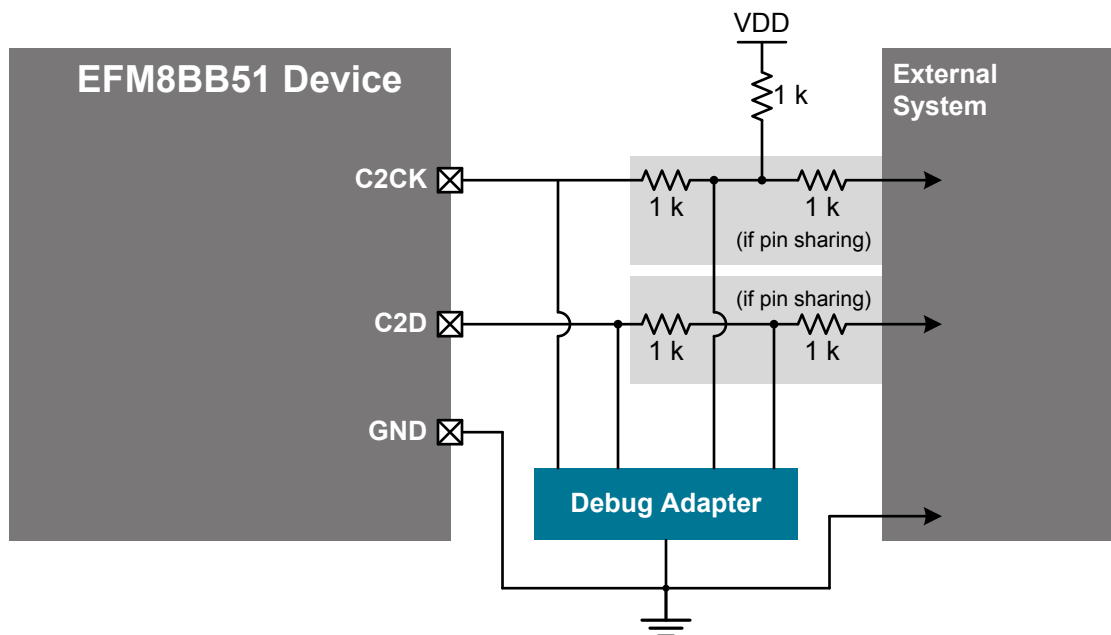

Figure 5.2. Debug Connection Diagram

### 5.3 Other Connections

Other components or connections may be required to meet the system-level requirements. Application Note *AN203: 8-bit MCU Printed Circuit Board Design Notes* contains detailed information on these connections. Application Notes can be accessed on the Silicon Labs website ([www.silabs.com/8bit-appnotes](http://www.silabs.com/8bit-appnotes)).

## 6. Pin Definitions

### 6.1 EFM8BB51-QFN20 Pin Definitions

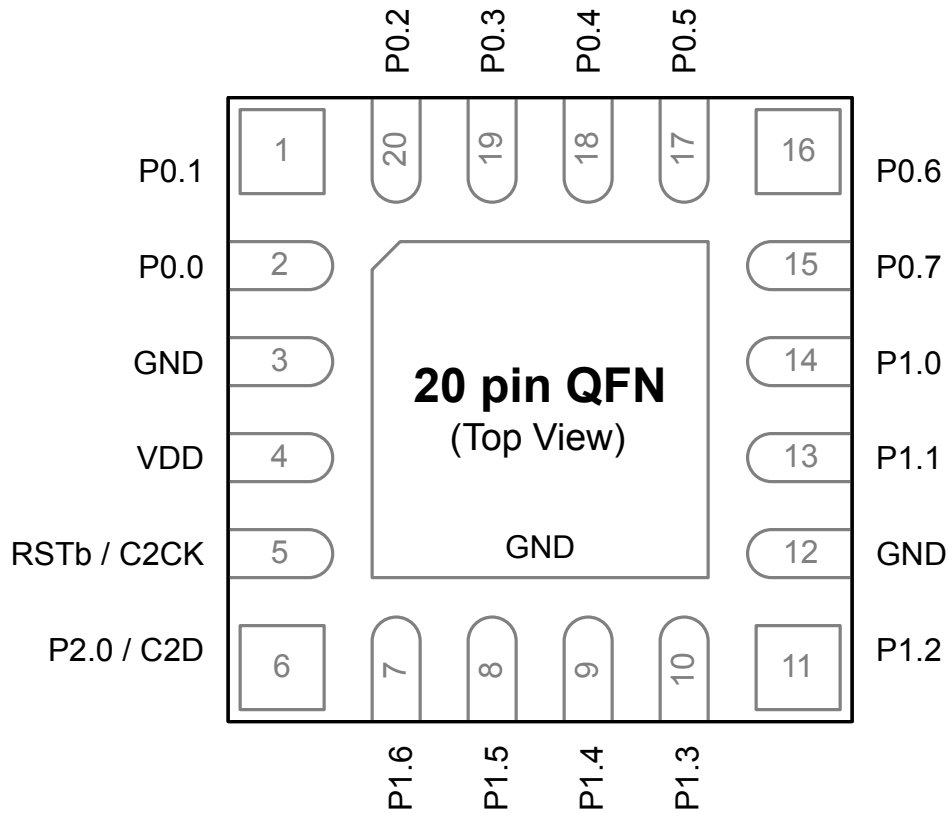

Figure 6.1. EFM8BB51-QFN20 Pinout

Table 6.1. Pin Definitions for EFM8BB51-QFN20

Pin Number	Pin Name	Description	Crossbar Capability	Additional Digital Functions	Analog Functions
1	P0.1	Multifunction I/O	Yes	P0MAT.1 INT0.1 INT1.1 CLU0B.8 CLU2A.9 CLU3B.9	ADC0.AGND CMP0.P0

Pin Number	Pin Name	Description	Crossbar Capability	Additional Digital Functions	Analog Functions
2	P0.0	Multifunction I/O	Yes	P0MAT.0 INT0.0 INT1.0 CLU0A.8 CLU2A.8 CLU3B.8	ADC0.VREF CMP0.N0 VREFP.OUT
3	GND	Ground			
4	VDD	Supply Power Input			
5	RSTb / C2CK	Active-low Reset / C2 Debug Clock			
6	P2.0 / C2D	Multifunction I/O / C2 Debug Data			
7	P1.6	Multifunction I/O	Yes	P1MAT.6 CLU0A.15 CLU1B.12 CLU2A.12	ADC0.CH11 CMP1.N2
8	P1.5	Multifunction I/O	Yes	P1MAT.5 CLU3.OUT CLU0B.14 CLU1A.13 CLU2B.13	ADC0.CH10 CMP1.P3
9	P1.4	Multifunction I/O	Yes	P1MAT.4 CLU0A.14 CLU1A.12 CLU2B.12	ADC0.CH9 CMP1.P2
10	P1.3	Multifunction I/O	Yes	P1MAT.3 CLU2.OUT CLU0B.13 CLU1B.11 CLU2B.11 CLU3A.13	ADC0.CH8 CMP1.P1
11	P1.2	Multifunction I/O	Yes	P1MAT.2 CLU0A.13 CLU1A.11 CLU2B.10 CLU3A.12	ADC0.CH7 CMP1.N1

Pin Number	Pin Name	Description	Crossbar Capability	Additional Digital Functions	Analog Functions
12	GND	Ground			
13	P1.1	Multifunction I/O	Yes	P1MAT.1 CLU0B.12 CLU1B.10 CLU2A.11 CLU3B.13	ADC0.CH6 CMP1.N0
14	P1.0	Multifunction I/O	Yes	P1MAT.0 CLU0A.12 CLU1A.10 CLU2A.10 CLU3B.12	ADC0.CH5 CMP1.P0
15	P0.7	Multifunction I/O	Yes	P0MAT.7 INT0.7 INT1.7 CLU0B.11 CLU1B.9 CLU3A.11	ADC0.CH4 CMP0.N2
16	P0.6	Multifunction I/O	Yes	P0MAT.6 INT0.6 INT1.6 CLU0A.11 CLU1B.8 CLU3A.10	CMP0.P4
17	P0.5	Multifunction I/O	Yes	P0MAT.5 INT0.5 INT1.5 CLU1.OUT CLU0B.10 CLU1A.9 CLU3B.11	ADC0.CH3 CMP0.P3

Pin Number	Pin Name	Description	Crossbar Capability	Additional Digital Functions	Analog Functions
18	P0.4	Multifunction I/O	Yes	P0MAT.4 INT0.4 INT1.4 CLU0A.10 CLU1A.8 CLU3B.10	ADC0.CH2 CMP0.N1
19	P0.3	Multifunction I/O	Yes	P0MAT.3 EXTCLK INT0.3 INT1.3 CLU0B.9 CLU2B.9 CLU3A.9	ADC0.CH1 CMP0.P2
20	P0.2	Multifunction I/O	Yes	P0MAT.2 INT0.2 INT1.2 CLU0.OUT CLU0A.9 CLU2B.8 CLU3A.8	ADC0.CH0 CMP0.P1
Center	GND	Ground			

6.2 EFM8BB51-TSSOP20 Pin Definitions

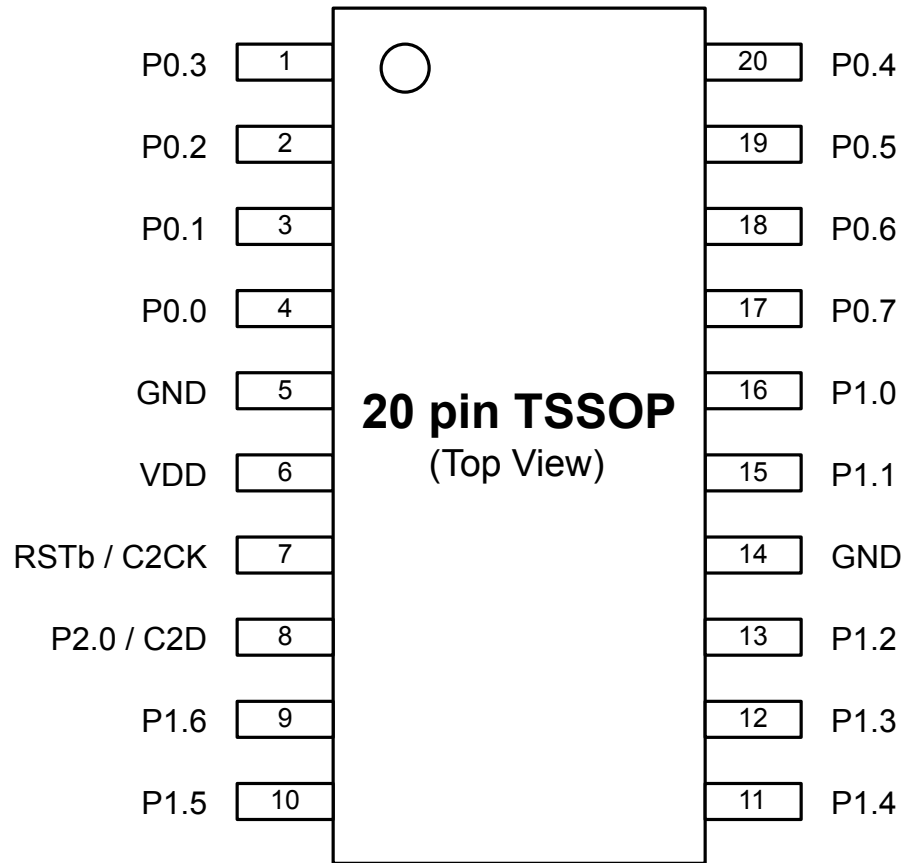

Figure 6.2. EFM8BB51-TSSOP20 Pinout

Table 6.2. Pin Definitions for EFM8BB51-TSSOP20

Pin Number	Pin Name	Description	Crossbar Capability	Additional Digital Functions	Analog Functions
1	P0.3	Multifunction I/O	Yes	P0MAT.3 EXTCLK INT0.3 INT1.3 CLU0B.9 CLU2B.9 CLU3A.9	ADC0.CH1 CMP0.P2



Pin Number	Pin Name	Description	Crossbar Capability	Additional Digital Functions	Analog Functions
2	P0.2	Multifunction I/O	Yes	P0MAT.2 INT0.2 INT1.2 CLU0.OUT CLU0A.9 CLU2B.8 CLU3A.8	ADC0.CH0 CMP0.P1
3	P0.1	Multifunction I/O	Yes	P0MAT.1 INT0.1 INT1.1 CLU0B.8 CLU2A.9 CLU3B.9	ADC0.AGND CMP0.P0
4	P0.0	Multifunction I/O	Yes	P0MAT.0 INT0.0 INT1.0 CLU0A.8 CLU2A.8 CLU3B.8	ADC0.VREF CMP0.N0 VREFP.OUT
5	GND	Ground			
6	VDD	Supply Power Input			
7	RSTb / C2CK	Active-low Reset / C2 Debug Clock			
8	P2.0 / C2D	Multifunction I/O / C2 Debug Data			
9	P1.6	Multifunction I/O	Yes	P1MAT.6 CLU0A.15 CLU1B.12 CLU2A.12	ADC0.CH11 CMP1.N2
10	P1.5	Multifunction I/O	Yes	P1MAT.5 CLU3.OUT CLU0B.14 CLU1A.13 CLU2B.13	ADC0.CH10 CMP1.P3

Pin Number	Pin Name	Description	Crossbar Capability	Additional Digital Functions	Analog Functions
11	P1.4	Multifunction I/O	Yes	P1MAT.4 CLU0A.14 CLU1A.12 CLU2B.12	ADC0.CH9 CMP1.P2
12	P1.3	Multifunction I/O	Yes	P1MAT.3 CLU2.OUT CLU0B.13 CLU1B.11 CLU2B.11 CLU3A.13	ADC0.CH8 CMP1.P1
13	P1.2	Multifunction I/O	Yes	P1MAT.2 CLU0A.13 CLU1A.11 CLU2B.10 CLU3A.12	ADC0.CH7 CMP1.N1
14	GND	Ground			
15	P1.1	Multifunction I/O	Yes	P1MAT.1 CLU0B.12 CLU1B.10 CLU2A.11 CLU3B.13	ADC0.CH6 CMP1.N0
16	P1.0	Multifunction I/O	Yes	P1MAT.0 CLU0A.12 CLU1A.10 CLU2A.10 CLU3B.12	ADC0.CH5 CMP1.P0
17	P0.7	Multifunction I/O	Yes	P0MAT.7 INT0.7 INT1.7 CLU0B.11 CLU1B.9 CLU3A.11	ADC0.CH4 CMP0.N2

Pin Number	Pin Name	Description	Crossbar Capability	Additional Digital Functions	Analog Functions
18	P0.6	Multifunction I/O	Yes	P0MAT.6 INT0.6 INT1.6 CLU0A.11 CLU1B.8 CLU3A.10	CMP0.P4
19	P0.5	Multifunction I/O	Yes	P0MAT.5 INT0.5 INT1.5 CLU1.OUT CLU0B.10 CLU1A.9 CLU3B.11	ADC0.CH3 CMP0.P3
20	P0.4	Multifunction I/O	Yes	P0MAT.4 INT0.4 INT1.4 CLU0A.10 CLU1A.8 CLU3B.10	ADC0.CH2 CMP0.N1

### 6.3 Crossbar Functional Map

The figure below shows all of the potential peripheral-to-pin assignments available to the crossbar. Note that this does not mean any peripheral can always be assigned to the highlighted pins. The actual pin assignments are determined by the priority of the enabled peripherals.

Port	P0							P1							P2	
Pin Number	0	1	2	3	4	5	6	7	0	1	2	3	4	5	6	0
Special Fixed-Location Functions	VREF	AGND	CLU0OUT	EXTCLK		CLU1OUT						CLU2OUT		CLU3OUT		C2D
UART0-TX																
UART0-RX																
SPI0-SCK																
SPI0-MISO																
SPI0-MOSI																
SPI0-NSS*																
SMB0-SDA																
SMB0-SCL																
CMP0-CP0																
CMP0-CP0A																
CMP1-CP1																
CMP1-CP1A																
SYSCLK																
PCA0-CEX0																
PCA0-CEX1																
PCA0-CEX2																
PCA0-ECI																
Timer0-T0																
Timer1-T1																
Timer2-T2																
UART1-TX																
UART1-RX																
UART1-RTS																
UART1-CTS																
PWM0-CH0X																
PWM0-CH0Y																
PWM0-CH1X																
PWM0-CH1Y																
PWM0-CH2X																
PWM0-CH2Y																
Pin Skip Settings	0	0	0	0	0	0	0	0	0	0	0	0	0	0	0	0
	P0SKIP							P1SKIP								

The crossbar peripherals are assigned in priority order from top to bottom.

- These boxes represent Port pins which can potentially be assigned to a peripheral.
- Special Function Signals are not assigned by the crossbar. When these signals are enabled, the Crossbar should be manually configured to skip the corresponding port pins.
- Pins can be "skipped" by setting the corresponding bit in PnSKIP to 1.

\* NSS is only pinned out when the SPI is in 4-wire mode.

Figure 6.3. Full Crossbar Map

## 7. QFN20 Package Specifications

### 7.1 QFN20 Package Dimensions

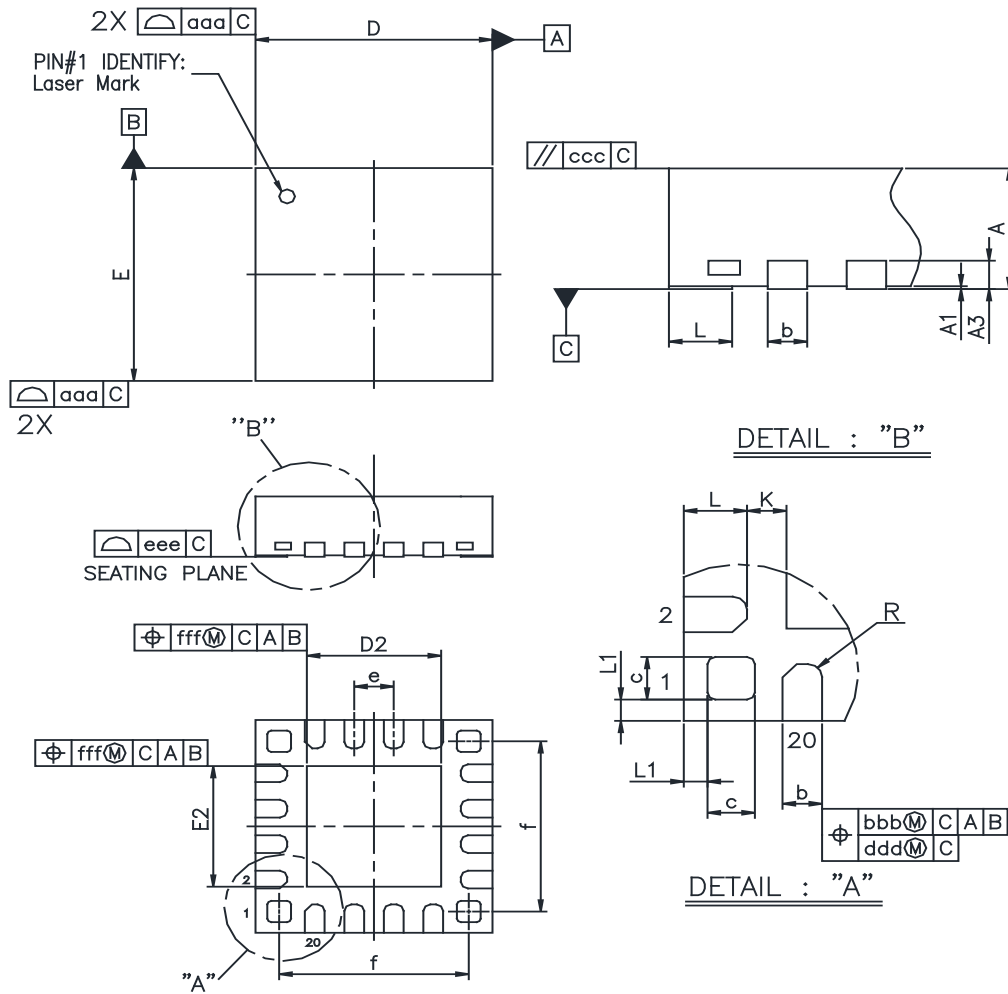

Figure 7.1. QFN20 Package Drawing

Table 7.1. QFN20 Package Dimensions

Dimension	Min	Typ	Max
A	0.70	0.75	0.80
A1	0.00	0.02	0.05
A3		0.20 REF	
b	0.18	0.25	0.30
c	0.25	0.30	0.35
D		3.00 BSC	
D2	1.6	1.70	1.80
e		0.50 BSC	
E		3.00 BSC	

Dimension	Min	Typ	Max
E2	1.60	1.70	1.80
f	2.50 BSC		
L	0.30	0.40	0.50
K	0.25 REF		
R	0.09	0.125	0.15
aaa	0.15		
bbb	0.10		
ccc	0.10		
ddd	0.05		
eee	0.08		
fff	0.10		

**Note:**

1. All dimensions shown are in millimeters (mm) unless otherwise noted.
2. Dimensioning and Tolerancing per ANSI Y14.5M-1994.
3. The drawing complies with JEDEC MO-220.
4. Recommended card reflow profile is per the JEDEC/IPC J-STD-020 specification for Small Body Components.

7.2 QFN20 PCB Land Pattern

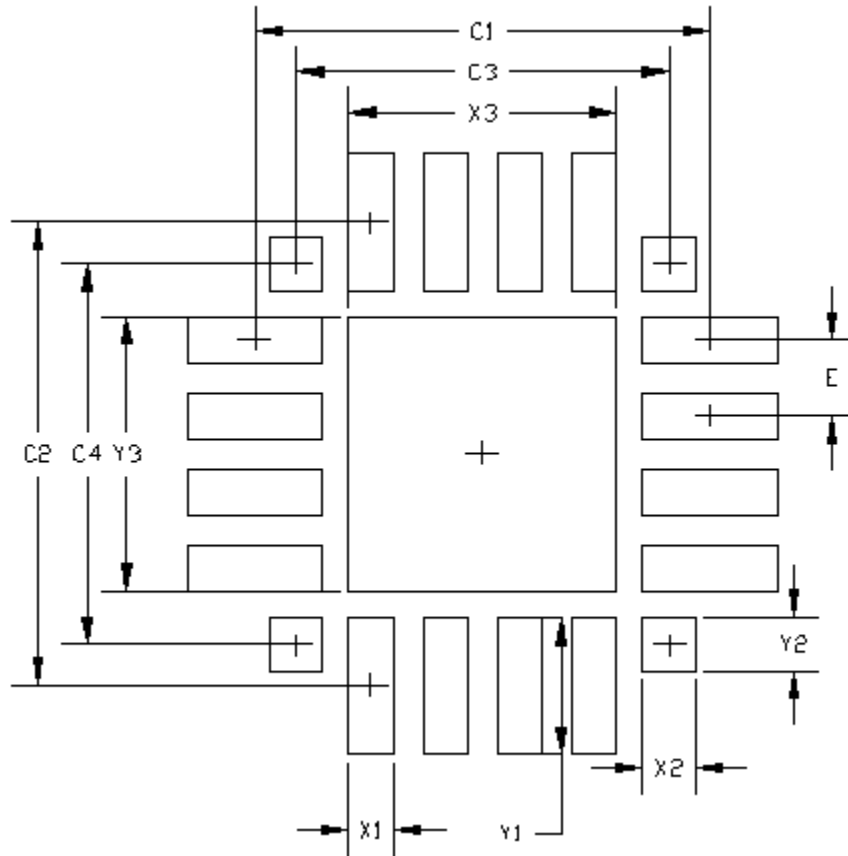

Figure 7.2. QFN20 PCB Land Pattern Drawing

Table 7.2. QFN20 PCB Land Pattern Dimensions

Dimension	Min	Max
C1		3.10
C2		3.10
C3		2.50
C4		2.50
E		0.50
X1		0.30
X2	0.25	0.35
X3		1.80
Y1		0.90
Y2	0.25	0.35
Y3		1.80



Dimension	Min	Max
<b>Note:</b>		
1. All dimensions shown are in millimeters (mm) unless otherwise noted.		
2. Dimensioning and Tolerancing is per the ANSI Y14.5M-1994 specification.		
3. This Land Pattern Design is based on the IPC-7351 guidelines.		
4. All metal pads are to be non-solder mask defined (NSMD). Clearance between the solder mask and the metal pad is to be 60 µm minimum, all the way around the pad.		
5. A stainless steel, laser-cut and electro-polished stencil with trapezoidal walls should be used to assure good solder paste release.		
6. The stencil thickness should be 0.125 mm (5 mils).		
7. The ratio of stencil aperture to land pad size should be 1:1 for the perimeter pads.		
8. A 2 x 2 array of 0.75 mm openings on a 0.95 mm pitch should be used for the center pad to assure proper paste volume.		
9. A No-Clean, Type-3 solder paste is recommended.		
10. The recommended card reflow profile is per the JEDEC/IPC J-STD-020 specification for Small Body Components.		

### 7.3 QFN20 Package Marking

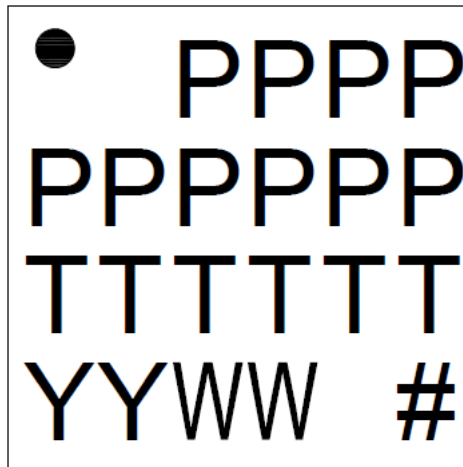

Figure 7.3. QFN20 Package Marking

The package marking consists of:

- P P P P P P P P – The part number designation.
- T T T T T T – A trace or manufacturing code.
- Y Y – The last 2 digits of the assembly year.
- W W – The 2-digit workweek when the device was assembled.
- # – The device revision (A, B, etc.).

**Note:** Firmware revision is not part of the package marking.

## 8. TSSOP20 Package Specifications

### 8.1 TSSOP20 Package Dimensions

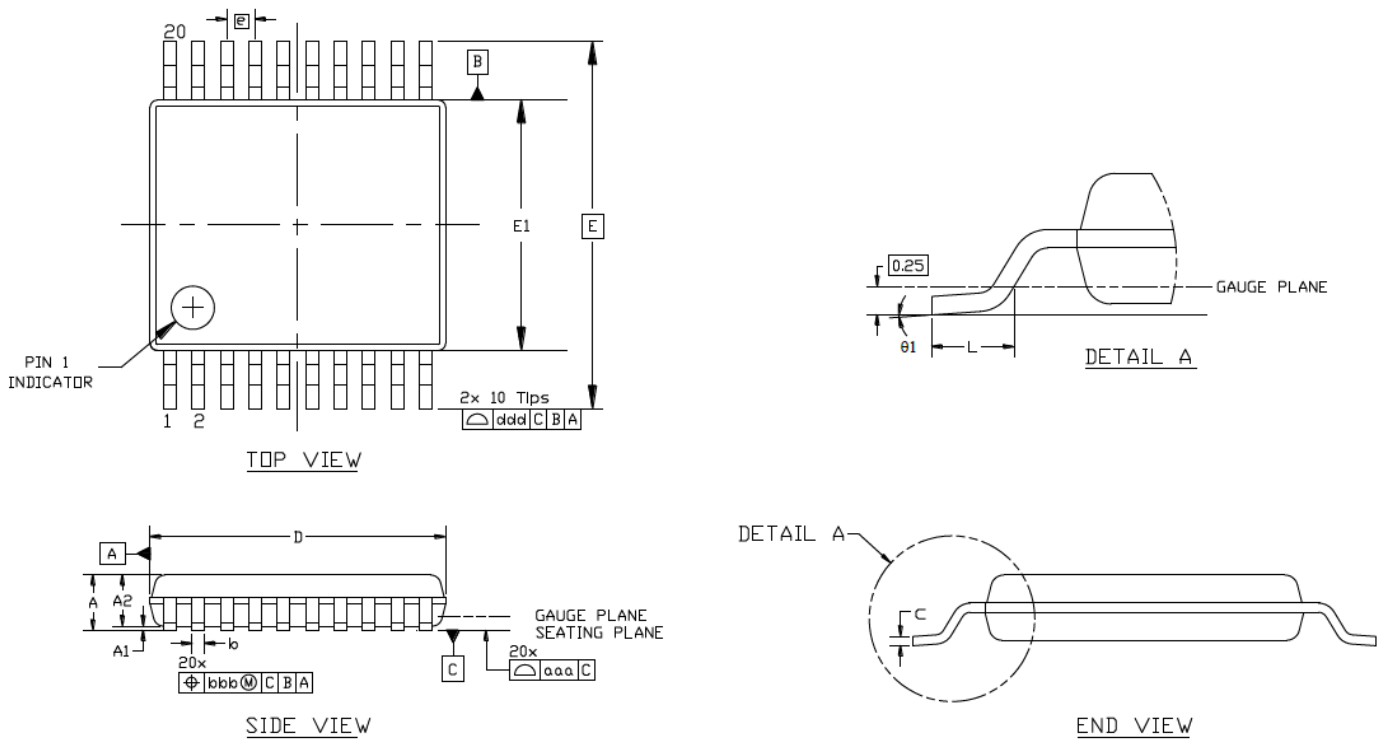

Figure 8.1. TSSOP20 Package Drawing

Table 8.1. TSSOP20 Package Dimensions

Dimension	Min	Nom	Max
A	—	—	1.20
A1	0.05	—	0.15
A2	0.80	1.00	1.05
b	0.19	—	0.30
c	0.09	—	0.20
D	6.40	6.50	6.60
e	0.65 BSC		
E	6.40 BSC		
E1	4.30	4.40	4.50
L	0.45	0.60	0.75
θ1	0°	—	8°
aaa	0.10		
bbb	0.10		
ddd	0.20		

Dimension	Min	Nom	Max
<p><b>Note:</b></p> <ol style="list-style-type: none"><li>1. All dimensions shown are in millimeters (mm) unless otherwise noted.</li><li>2. Dimensioning and Tolerancing per ANSI Y14.5M-1994.</li><li>3. This drawing conforms to the JEDEC Solid State Outline MO-153, Variation AC.</li><li>4. Recommended card reflow profile is per the JEDEC/IPC J-STD-020 specification for Small Body Components.</li></ol>			

## 8.2 TSSOP20 PCB Land Pattern

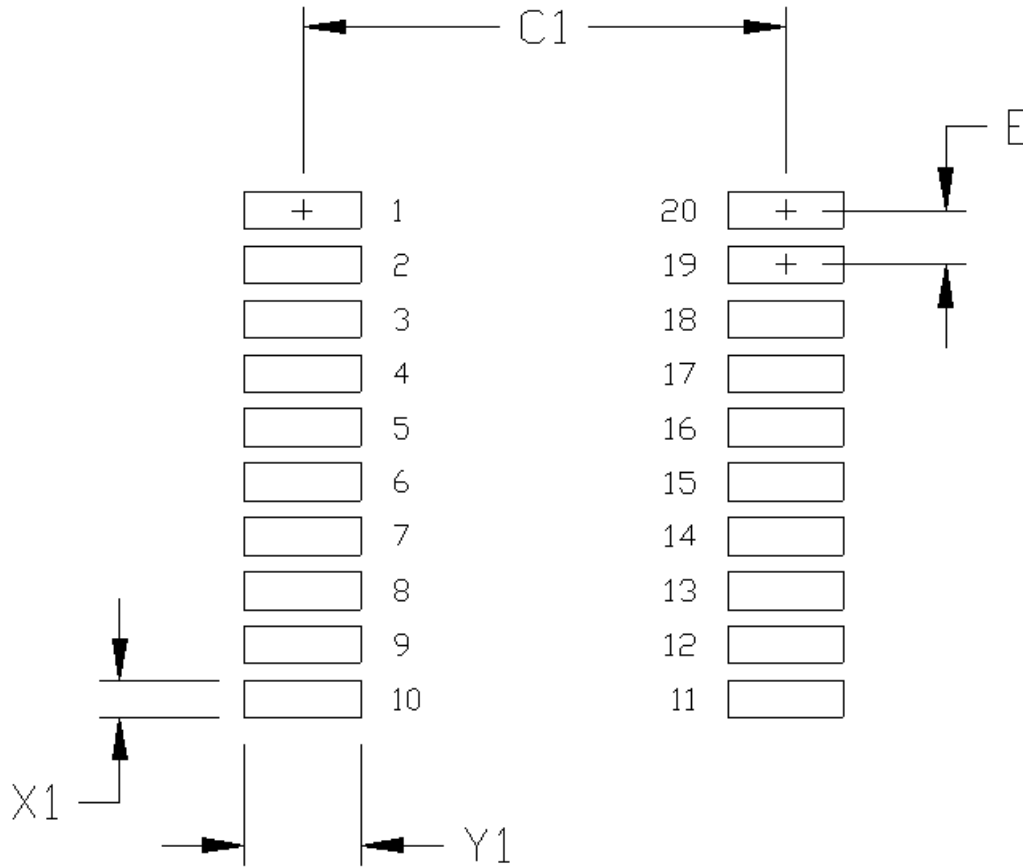

Figure 8.2. TSSOP20 PCB Land Pattern Drawing

Table 8.2. TSSOP20 PCB Land Pattern Dimensions

Dimension	Feature	(mm)
C1	Pad Column Spacing	5.80
E	Pad Row Pitch	0.65
X1	Pad Width	0.45
Y1	Pad Length	1.40

**Note:**

1. All dimensions shown are in millimeters (mm) unless otherwise noted.
2. This Land Pattern Design is based on IPC-7351 pattern SOIC127P600X165-16N for Density Level B (Median Land Protrusion).
3. All feature sizes shown are at Maximum Material Condition (MMC) and a card fabrication tolerance of 0.05 mm is assumed.

### 8.3 TSSOP20 Package Marking

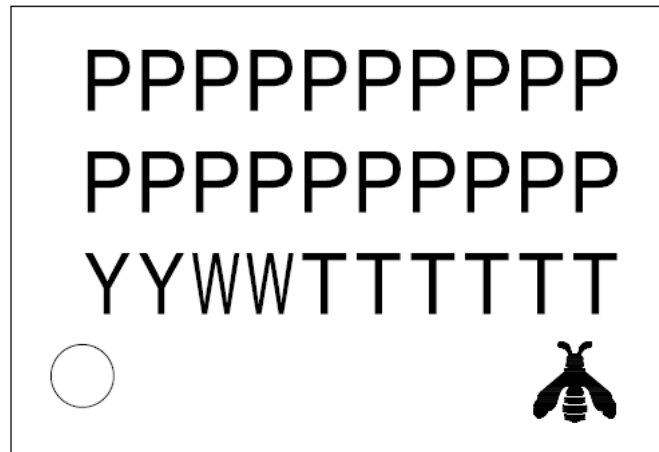

**Figure 8.3. TSSOP20 Package Marking**

The package marking consists of:

- P P P P P P P P P P – The part number designation (2 lines).
- YY – The last 2 digits of the assembly year.
- WW – The 2-digit workweek when the device was assembled.
- T T T T T T – A trace or manufacturing code.

## 9. Revision History

### Revision 1.0

September, 2021

- Updated document to reflect revision C OPNs.
- Added section: [3.2 CIP-51 Microcontroller Core](#)
- Added section: [3.3 Memory](#)
- [4.1 Electrical Characteristics](#): Updated specification tables with latest characterization results and test limits and added typical performance curves for GPIO.
- Updated package marking diagrams.

### Revision 0.1

November, 2020

- Initial release.

# Simplicity Studio

One-click access to MCU and wireless tools, documentation, software, source code libraries & more. Available for Windows, Mac and Linux!



**IoT Portfolio**  
[www.silabs.com/IoT](http://www.silabs.com/IoT)



**SW/HW**  
[www.silabs.com/simplicity](http://www.silabs.com/simplicity)



**Quality**  
[www.silabs.com/quality](http://www.silabs.com/quality)



**Support & Community**  
[www.silabs.com/community](http://www.silabs.com/community)

## Disclaimer

Silicon Labs intends to provide customers with the latest, accurate, and in-depth documentation of all peripherals and modules available for system and software implementers using or intending to use the Silicon Labs products. Characterization data, available modules and peripherals, memory sizes and memory addresses refer to each specific device, and "Typical" parameters provided can and do vary in different applications. Application examples described herein are for illustrative purposes only. Silicon Labs reserves the right to make changes without further notice to the product information, specifications, and descriptions herein, and does not give warranties as to the accuracy or completeness of the included information. Without prior notification, Silicon Labs may update product firmware during the manufacturing process for security or reliability reasons. Such changes will not alter the specifications or the performance of the product. Silicon Labs shall have no liability for the consequences of use of the information supplied in this document. This document does not imply or expressly grant any license to design or fabricate any integrated circuits. The products are not designed or authorized to be used within any FDA Class III devices, applications for which FDA premarket approval is required or Life Support Systems without the specific written consent of Silicon Labs. A "Life Support System" is any product or system intended to support or sustain life and/or health, which, if it fails, can be reasonably expected to result in significant personal injury or death. Silicon Labs products are not designed or authorized for military applications. Silicon Labs products shall under no circumstances be used in weapons of mass destruction including (but not limited to) nuclear, biological or chemical weapons, or missiles capable of delivering such weapons. Silicon Labs disclaims all express and implied warranties and shall not be responsible or liable for any injuries or damages related to use of a Silicon Labs product in such unauthorized applications.

**Note: This content may contain offensive terminology that is now obsolete. Silicon Labs is replacing these terms with inclusive language wherever possible. For more information, visit [www.silabs.com/about-us/inclusive-lexicon-project](http://www.silabs.com/about-us/inclusive-lexicon-project)**

## Trademark Information

Silicon Laboratories Inc.<sup>®</sup>, Silicon Laboratories<sup>®</sup>, Silicon Labs<sup>®</sup>, SiLabs<sup>®</sup> and the Silicon Labs logo<sup>®</sup>, Bluegiga<sup>®</sup>, Bluegiga Logo<sup>®</sup>, EFM<sup>®</sup>, EFM32<sup>®</sup>, EFR, Ember<sup>®</sup>, Energy Micro, Energy Micro logo and combinations thereof, "the world's most energy friendly microcontrollers", Redpine Signals<sup>®</sup>, WiSeConnect, n-Link, ThreadArch<sup>®</sup>, EZLink<sup>®</sup>, EZRadio<sup>®</sup>, EZRadioPRO<sup>®</sup>, Gecko<sup>®</sup>, Gecko OS, Gecko OS Studio, Precision32<sup>®</sup>, Simplicity Studio<sup>®</sup>, Telegesis, the Telegesis Logo<sup>®</sup>, USBXpress<sup>®</sup>, Zentri, the Zentri logo and Zentri DMS, Z-Wave<sup>®</sup>, and others are trademarks or registered trademarks of Silicon Labs. ARM, CORTEX, Cortex-M3 and THUMB are trademarks or registered trademarks of ARM Holdings. Keil is a registered trademark of ARM Limited. Wi-Fi is a registered trademark of the Wi-Fi Alliance. All other products or brand names mentioned herein are trademarks of their respective holders.



Silicon Laboratories Inc.  
400 West Cesar Chavez  
Austin, TX 78701  
USA

[www.silabs.com](http://www.silabs.com)