

ISO VIEW

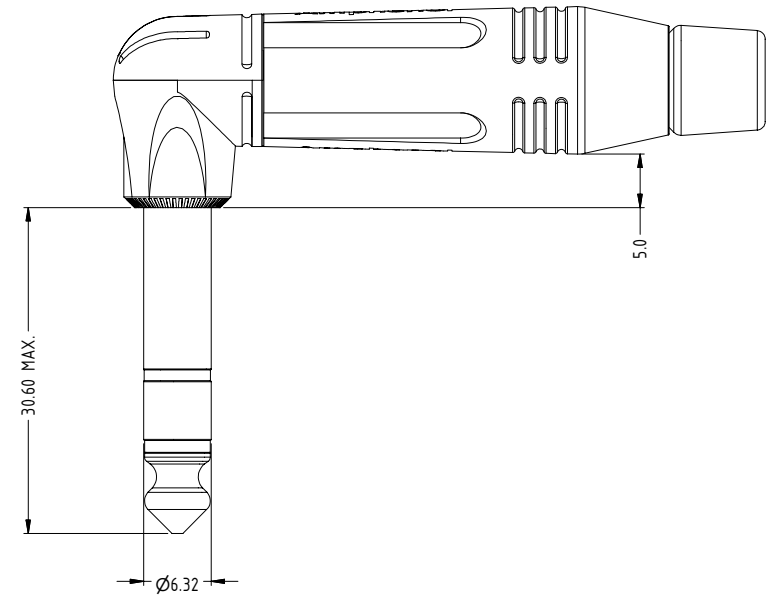
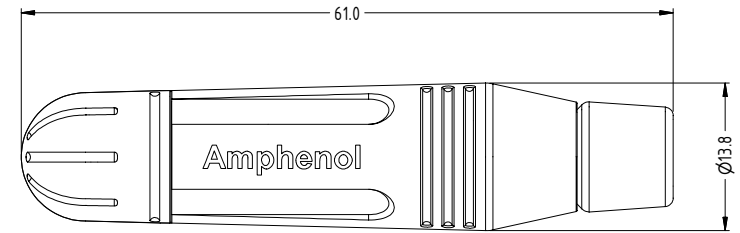
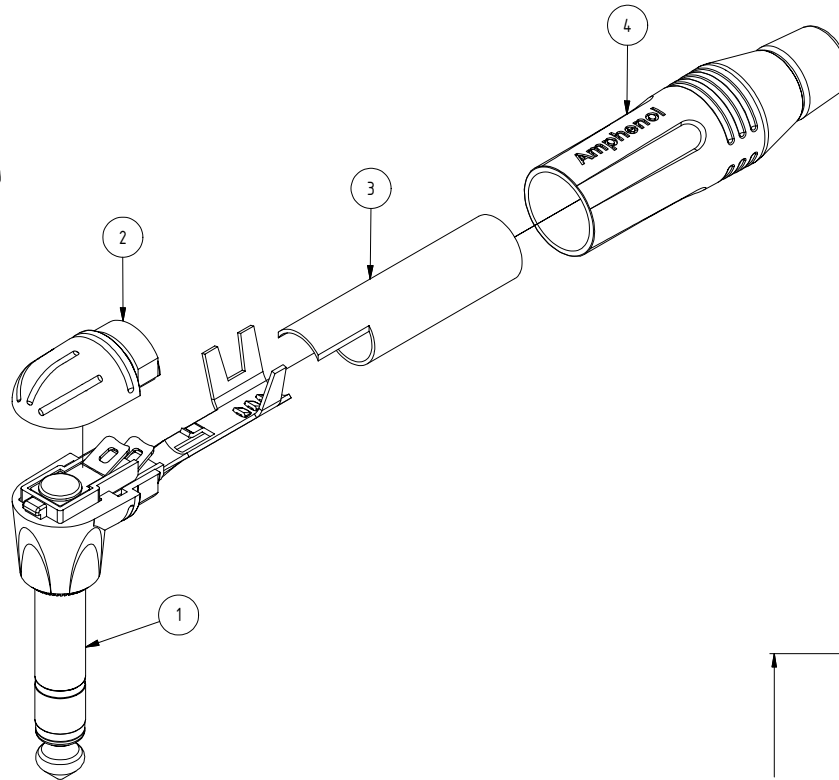
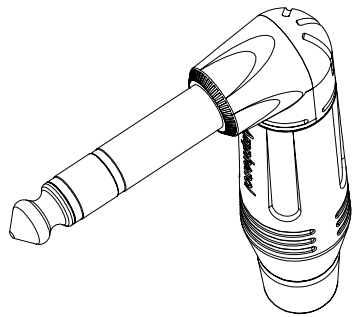

Stereo Connector Assembly - Parts List				
ITEM	PART NUMBER	DWG No	DESCRIPTION	QTY
1	50310027-*30	50310027-130-1	RA-STEREO PLUG INSERT CONTACT ASSEMBLY	1
2	50300105-*21	50300105-121-1	RA-TOP CAP	1
3	51270031-521	51270031-521-1	RA-BIG TUBE PVC INSULATOR	1
4	53490001-*31	53490001-331-1	M-SERIES BACKSHELL ASSEMBLY	1

Part Number according to Shell and Contact Finish			
CATALOGUE P/No.	REFERENCE P/No.	SHELL FINISH	CONTACT FINISH
ACPS-RN	55010302-000	NICKEL	NICKEL TIP, RING AND SLEEVE
ACPS-RN-AU	55010302-001	NICKEL	GOLD TIP, RING AND SLEEVE
ACPS-RB	55010302-002	BLACK	NICKEL TIP, RING AND SLEEVE
ACPS-RB-AU	55010302-003	BLACK	GOLD TIP, RING AND SLEEVE

UNLESS OTHERWISE SPECIFIED TOLERANCE TO BE		THIS DOCUMENT IS THE PROPERTY OF AMPHENOL AUSTRALIA PTY LTD. NO PART THEREOF MAY BE REPRODUCED AND USED WITHOUT THE PRIOR WRITTEN CONSENT OF THE OWNER				1	UPDATE ASSEMBLY TO COMPLY WITH MODIFIED COMPONENTS	L.V	10-05-05	8374
LINEAR		ANGULAR		CAD FILE: 55010302000111		0	FIRST ISSUE	L.V	26-08-04	----
X ± 0.5		X° ± 1		DSD: L.V		DATE: 26-08-04		TITLE: 1/4" PHONE PLUG RA - STEREO CONNECTOR ASSY		
XX ± 0.1		XX° ± 30'		MATERIAL: REFER TO COMPONENTS		DATE: 17-06-05		DRAWING NO. 55010302-000-1		
XXX ± 0.05		XXX° ± 15'		CKD: M.N.H		DATE: 29-06-05		SHEET 1/1		
DO NOT SCALE		FINISH: SEE TABLE		APP'D: P.M		SCALE: 2:1 UOS		PART No: REFER TO TABLE		
DIMENSIONS IN MILLIMETRES		THIRD ANGLE PROJECTION		SIZE: A3		REV. CHANGE DETAILS		BY DATE CHG/No		

Amphenol
Amphenol Australia Pty Ltd, 2 Finlayson Blvd, Melbourne, Vic3123