

***PLC
Cable and
Wiring Guide***

OMRON[®]

Table of Contents

<u>Name</u>	<u>Page Number</u>
PLC Connections	1
Cable Solutions for Omron PLCs	11
Cable Solutions for Multi-Vendor PLCs	15

Reference Information

PLC Connections

The following pages illustrate the cabling options for connecting Omron programmable controllers with computers, Omron's HMI's, hand-held programmers, high-density I/O modules and I/O terminal blocks.

Hand-held Programmers and CPM1A, CPM2A, SRM1 Peripheral Port

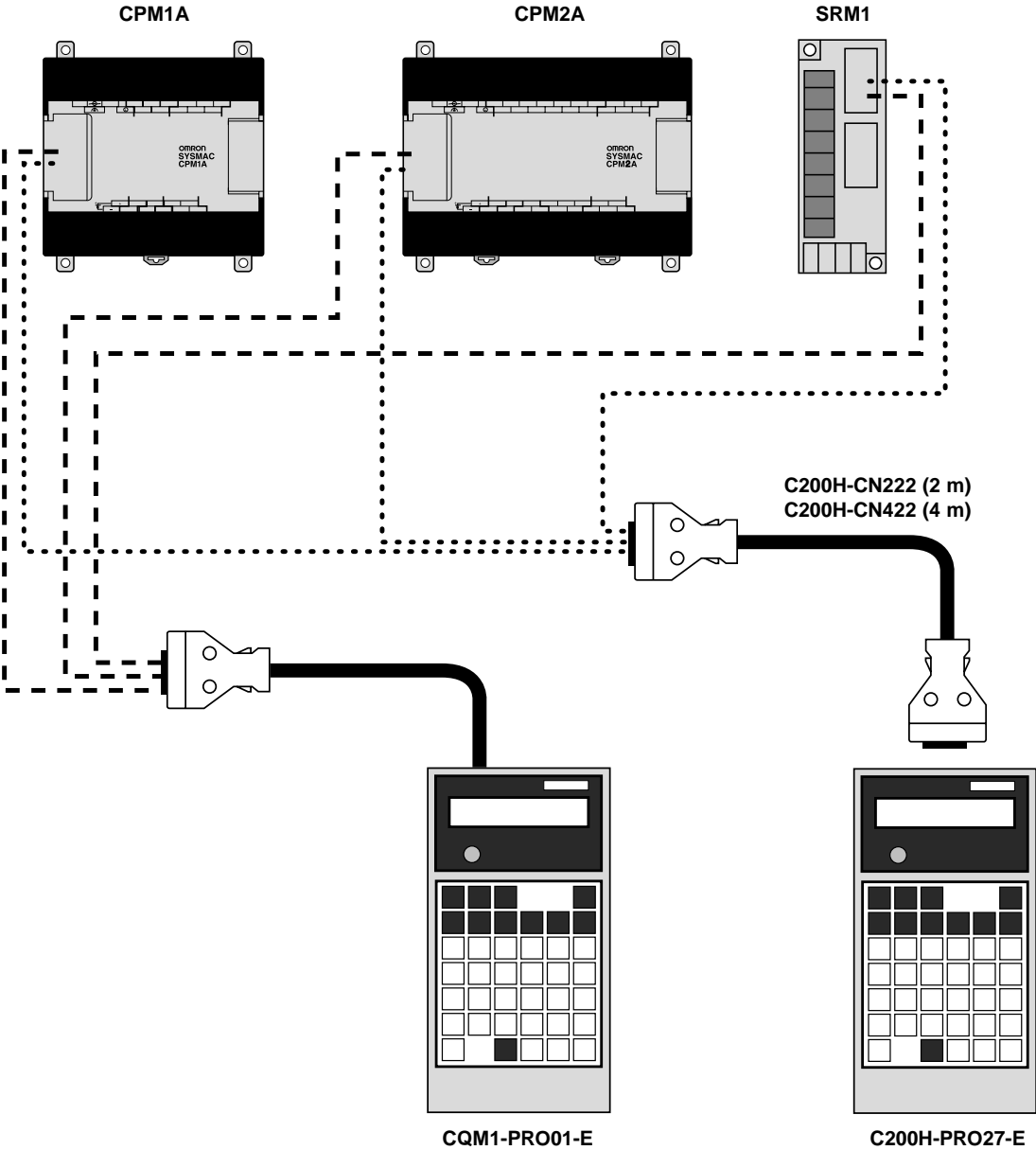

Reference Information

Hand-held Programmings and CQM1H Peripheral Port

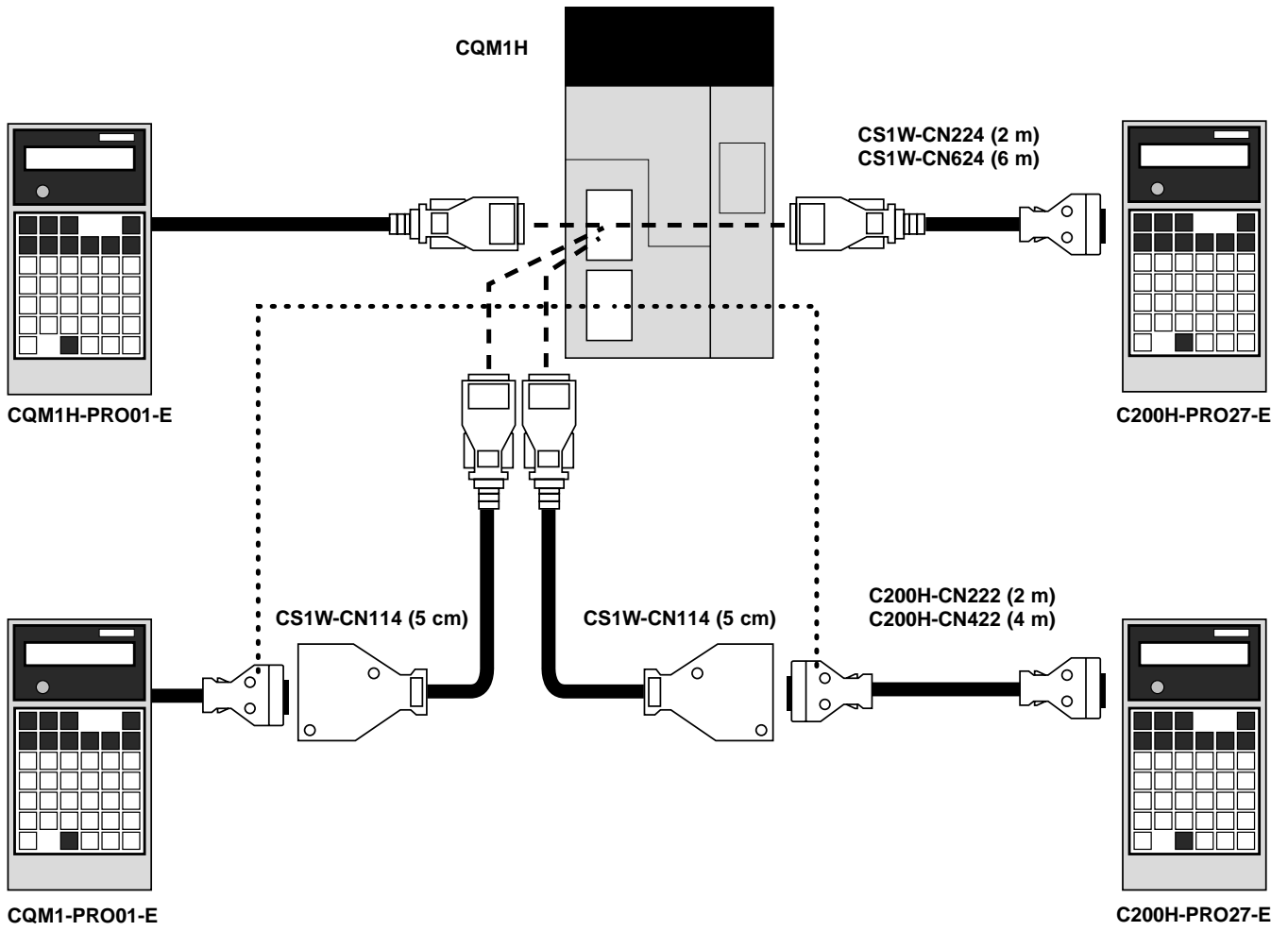

Reference Information

Hand-held Programmer and CPM2C Communication Port

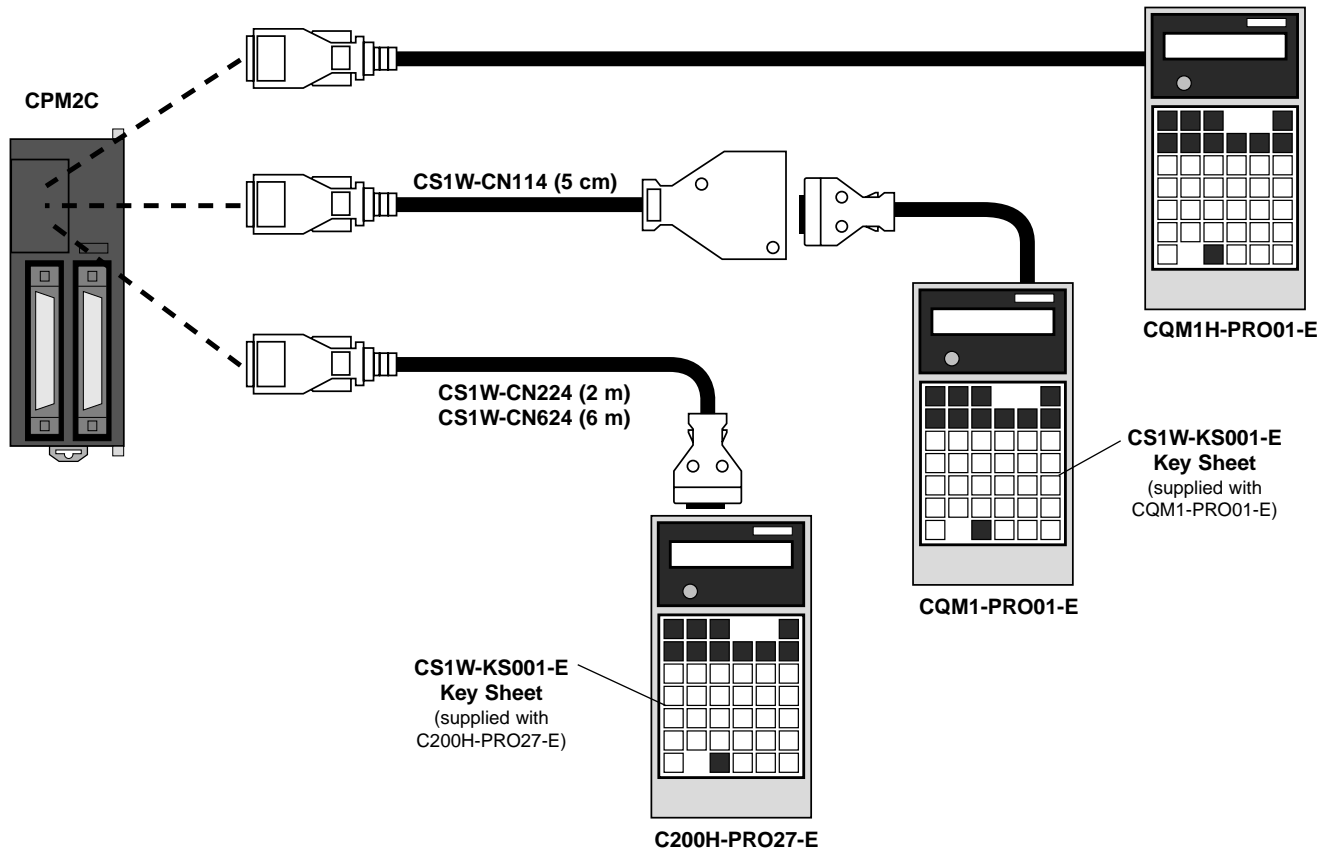

Reference Information

CQM1H and PC

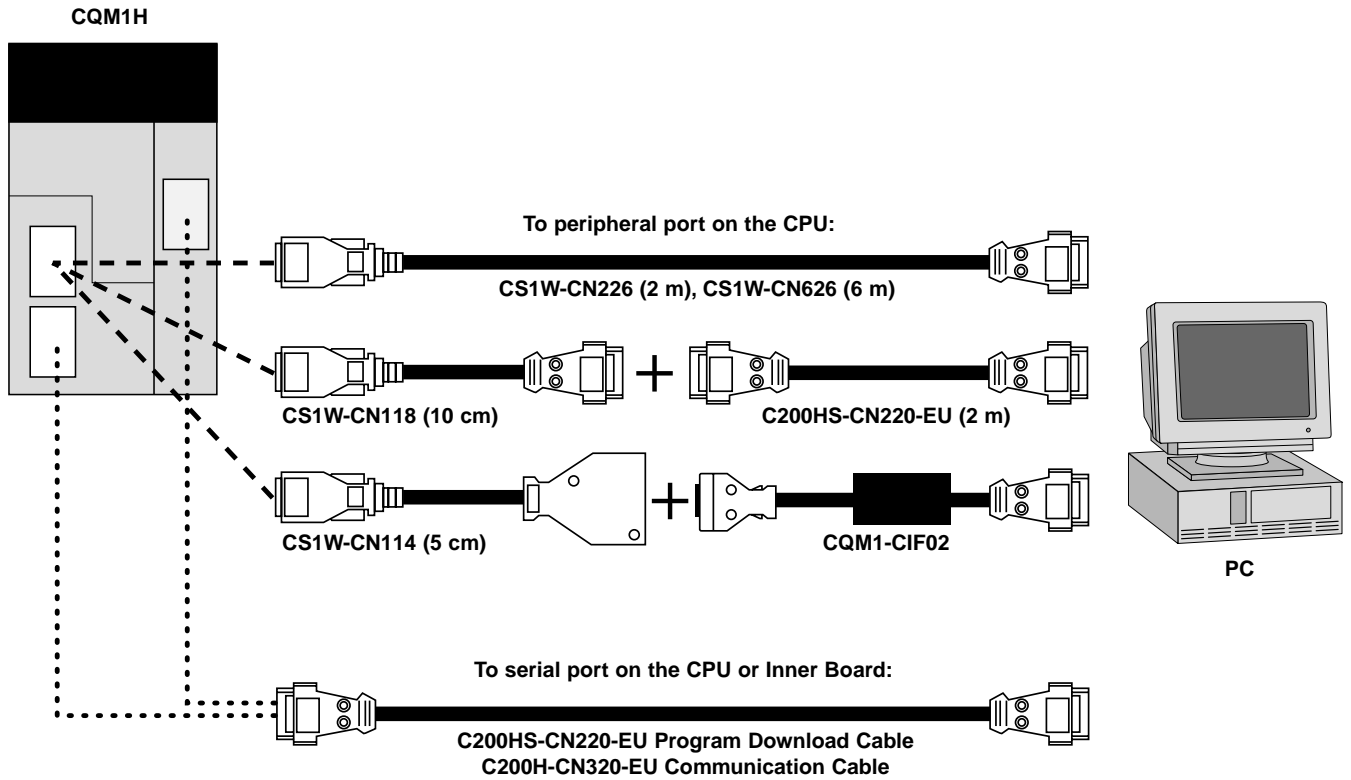

CPM2C and PC

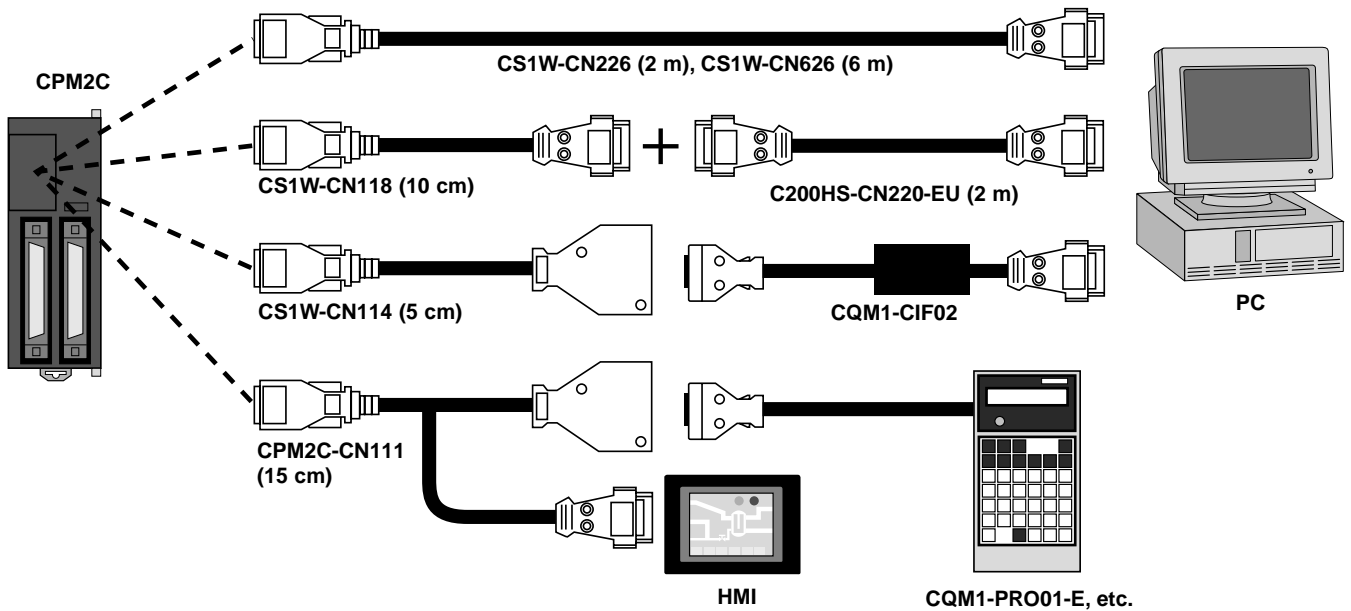

Reference Information

CPM2C + Serial Communication Adapter and PC

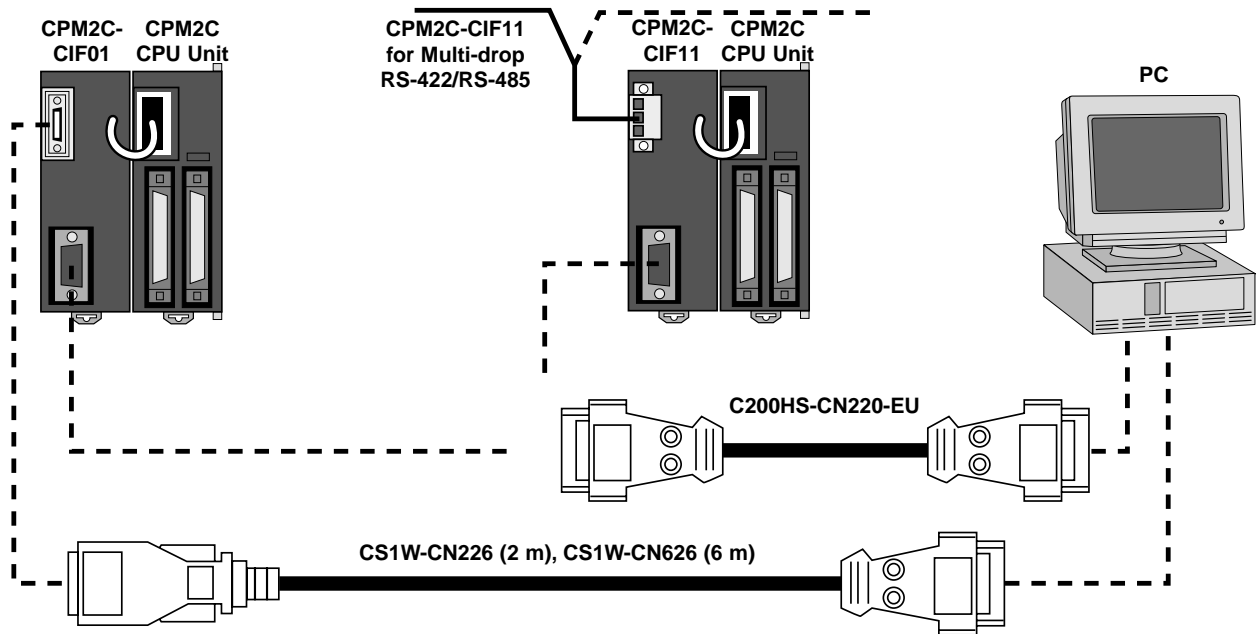

NT2S Message Display and Programmable Controllers

Peripheral port (Old type: C200H, SRM1, CPM2A, CPM1A, CPM2B*)

*Note: CPM2B must use CS1W-CN114 adapter.

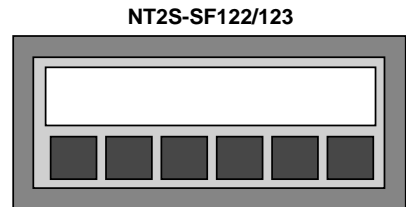
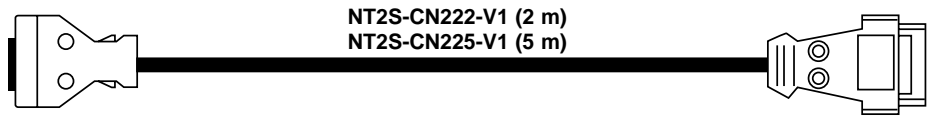
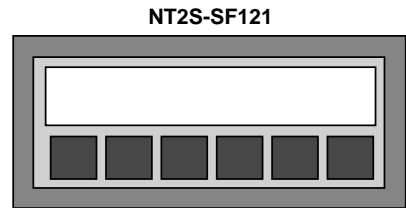
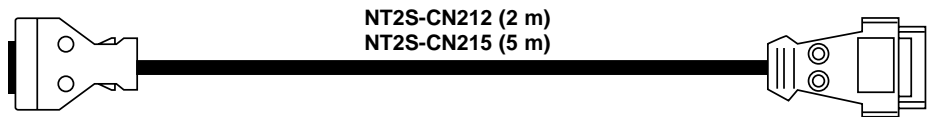

Peripheral port (New type: CS1, CQM1H, CPM2C)

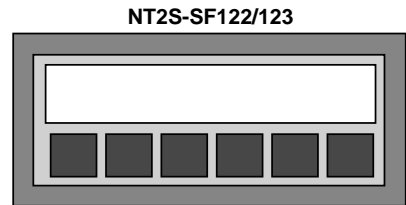
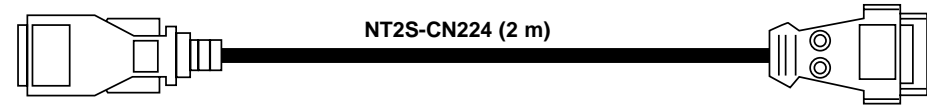
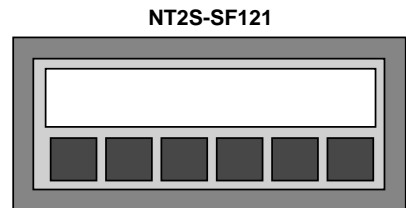
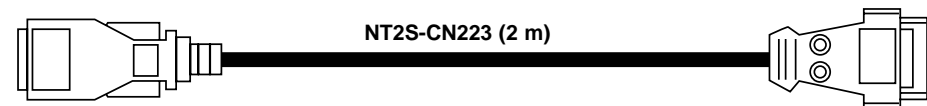

Reference Information

CPM2C CPU and Expansion I/O + XW2B/XW2C 20-pin Screw Terminal Blocks

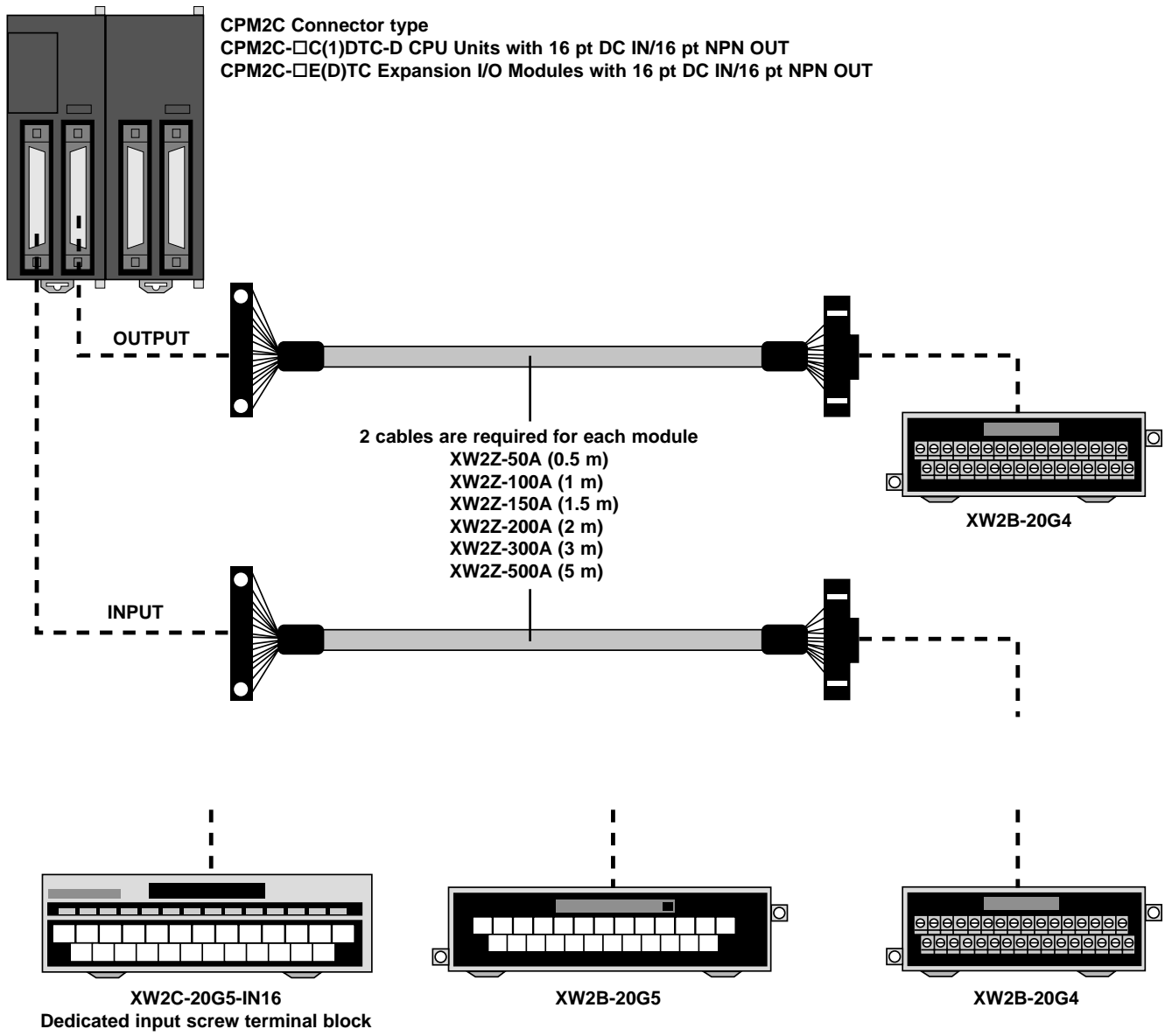

Reference Information

CPM2C CPU and Expansion I/O + G70A, G70D Relay I/O Blocks

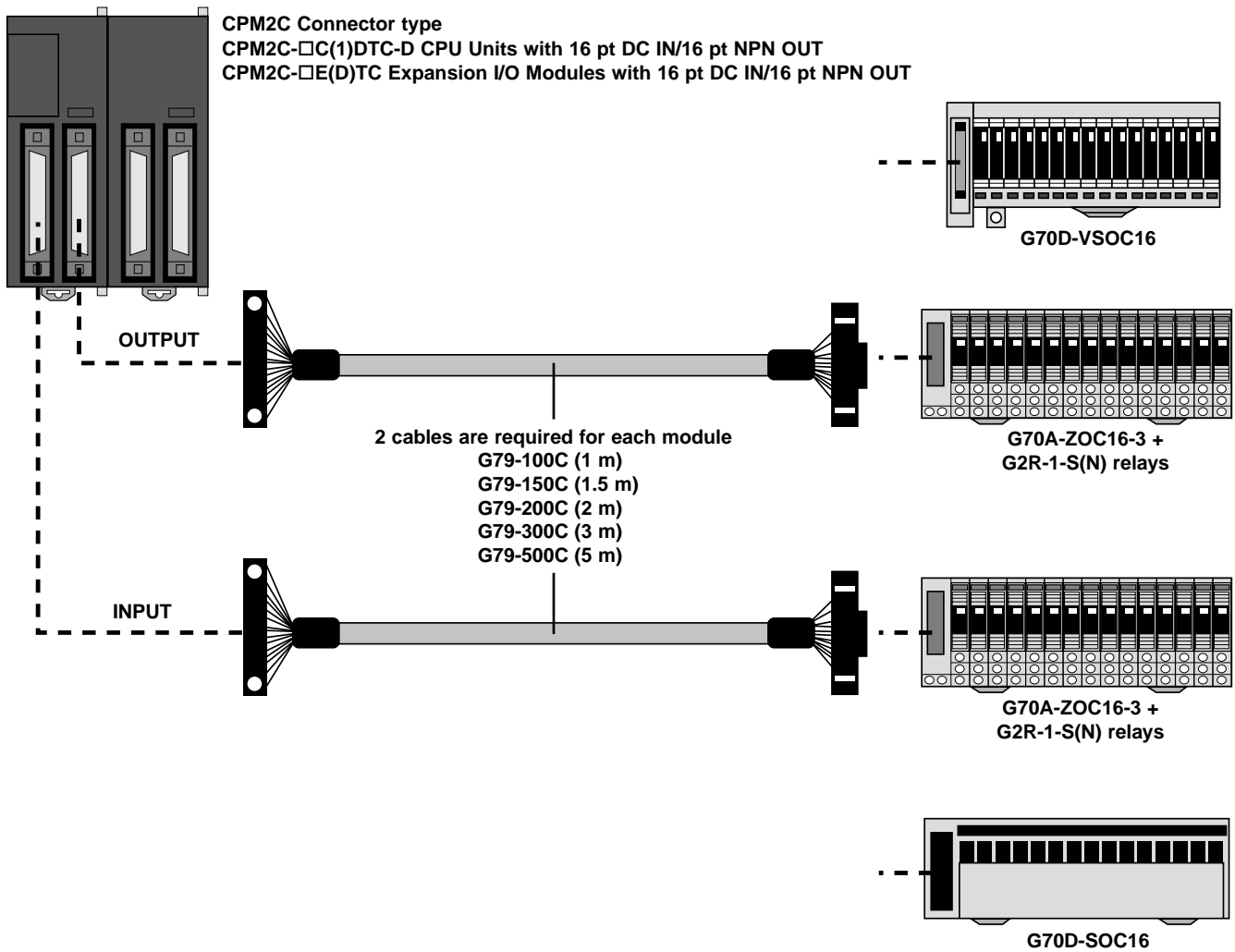

CQM1H 16-point PNP Output Module + G70A Relay I/O Block

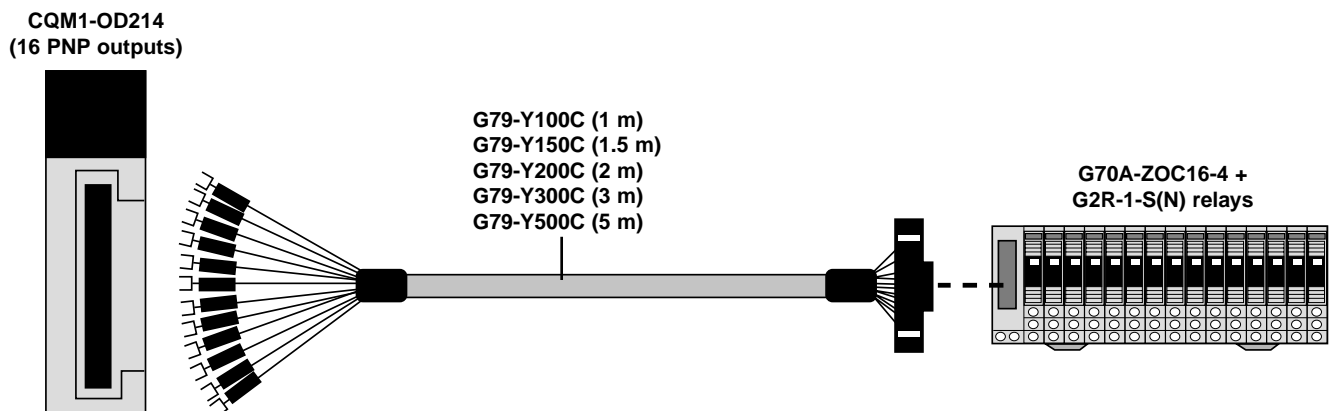

Reference Information

CQM1H High-Density I/O Modules + XW2B Screw Terminal Blocks

CQM1H 32-Point I/O Modules

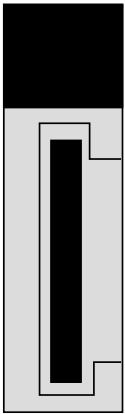

- CQM1-ID213 (32 NPN inputs)
- CQM1-ID214 (32 NPN inputs)
- CQM1-OD213 (32 NPN outputs)
- CQM1-OD216 (32 PNP outputs)

- XW2Z-50B (0.5 m)
- XW2Z-100B (1 m)
- XW2Z-150B (1.5 m)
- XW2Z-200B (2 m)
- XW2Z-300B (3 m)
- XW2Z-500B (5 m)

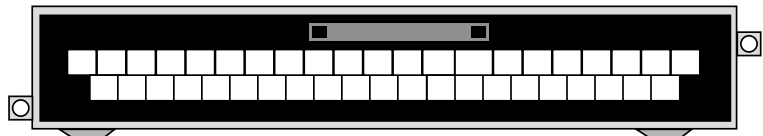
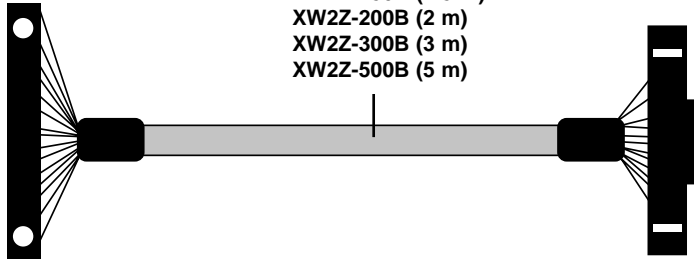

XW2B-40G5

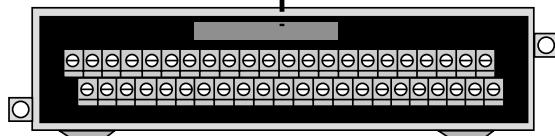

XW2B-40G4

Reference Information

CQM1H High-Density Input Modules + XW2C Input Screw Terminal Blocks

CQM1H 32-Point Input Modules

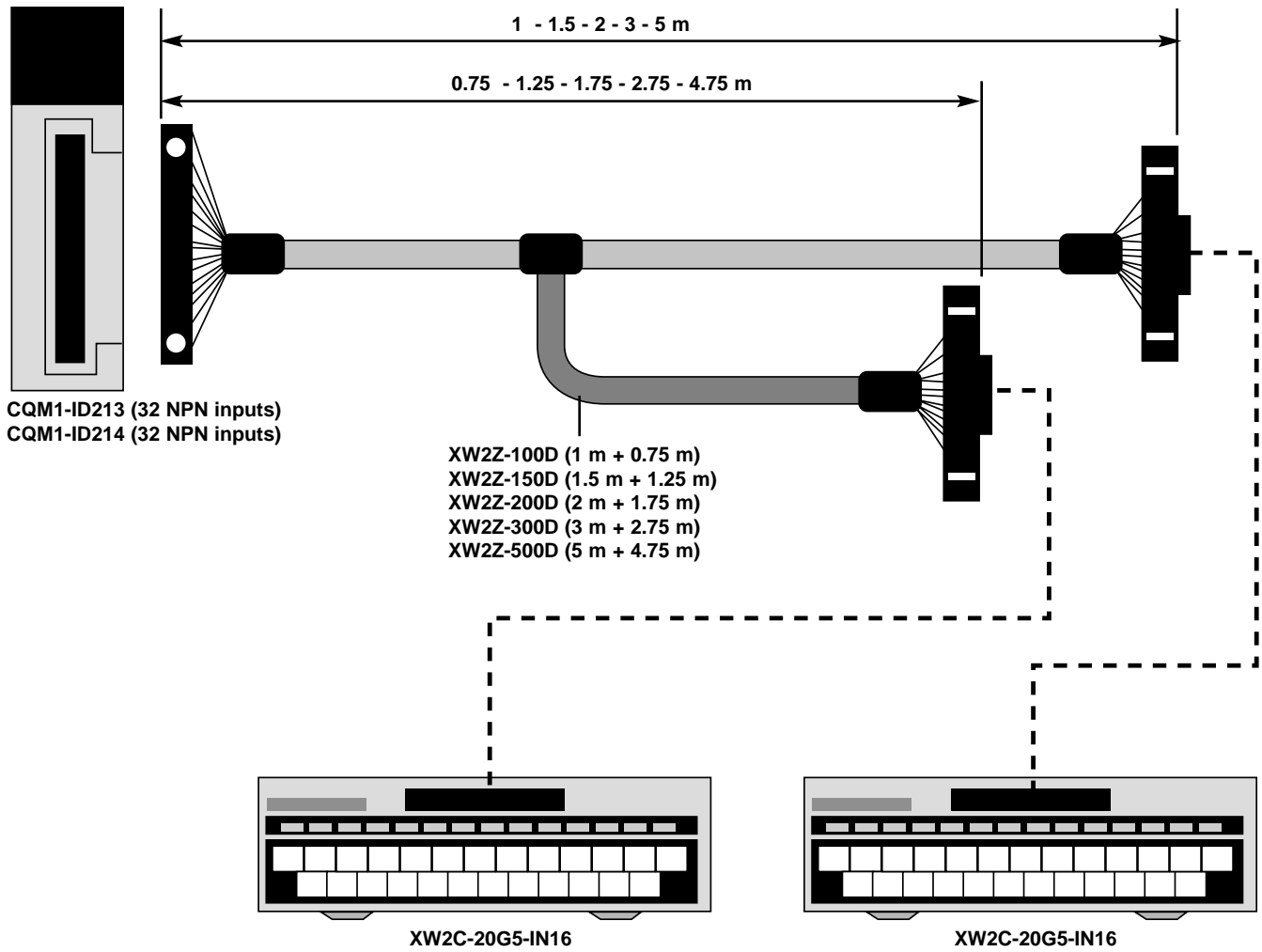

Reference Information

CQM1H High-Density Output Modules + Output Relay Blocks

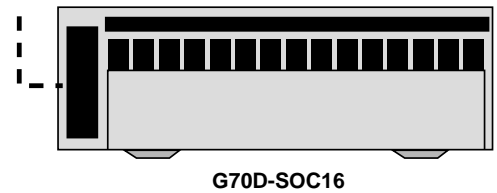
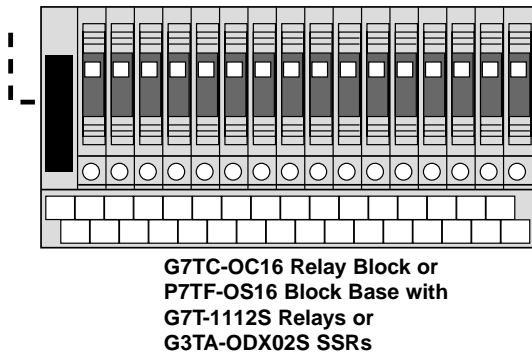
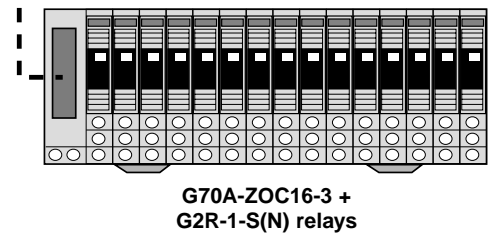
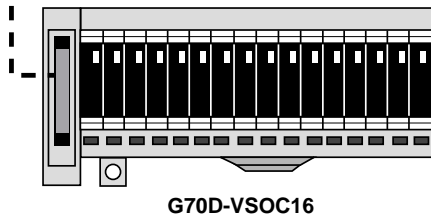
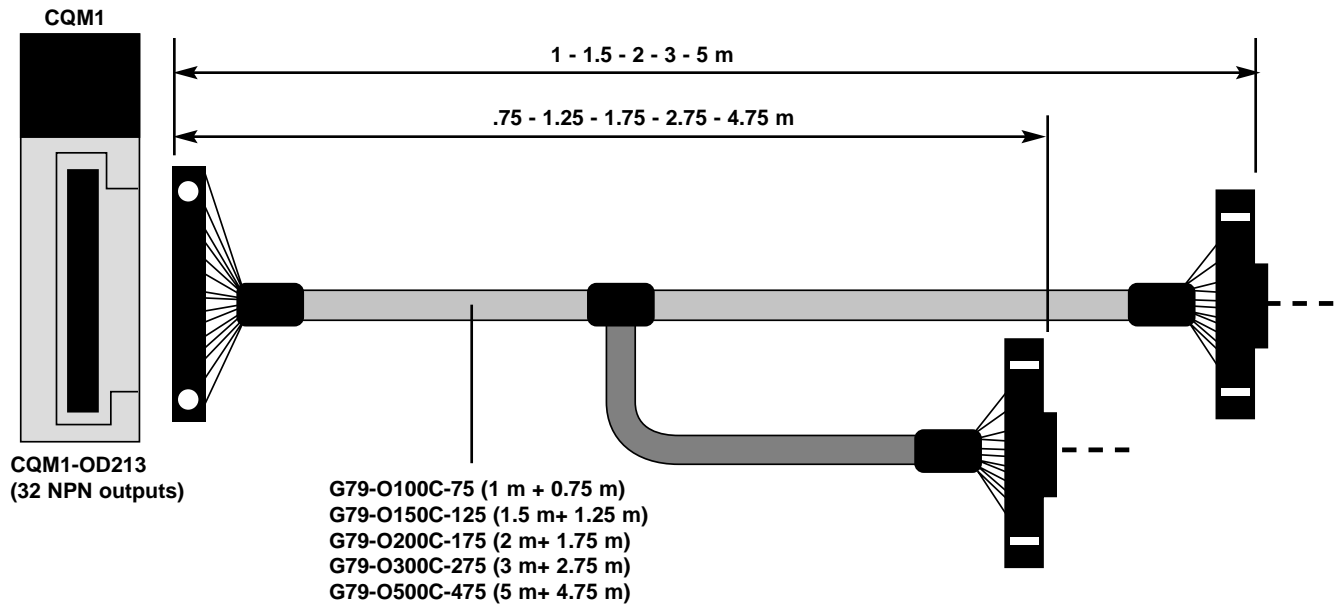

Cable Solutions for Omron PLCs

Operator Interface Terminals and CPM1A/CPM2A

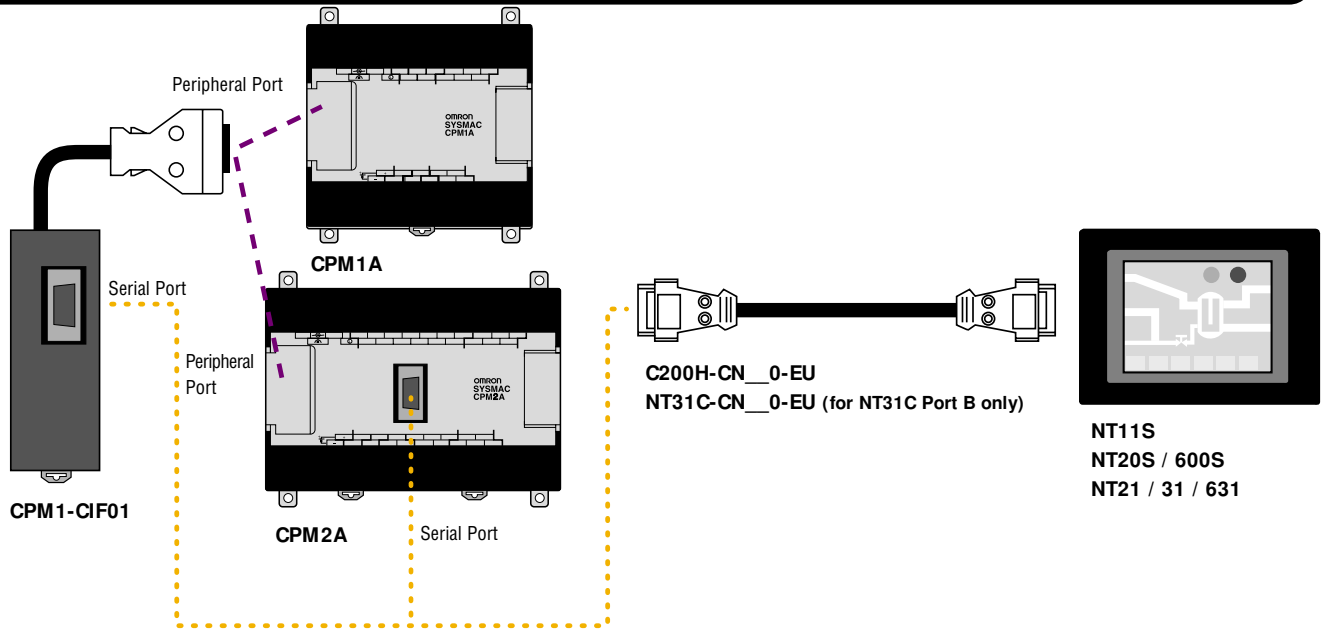

Operator Interface Terminals and CPM2C PLC

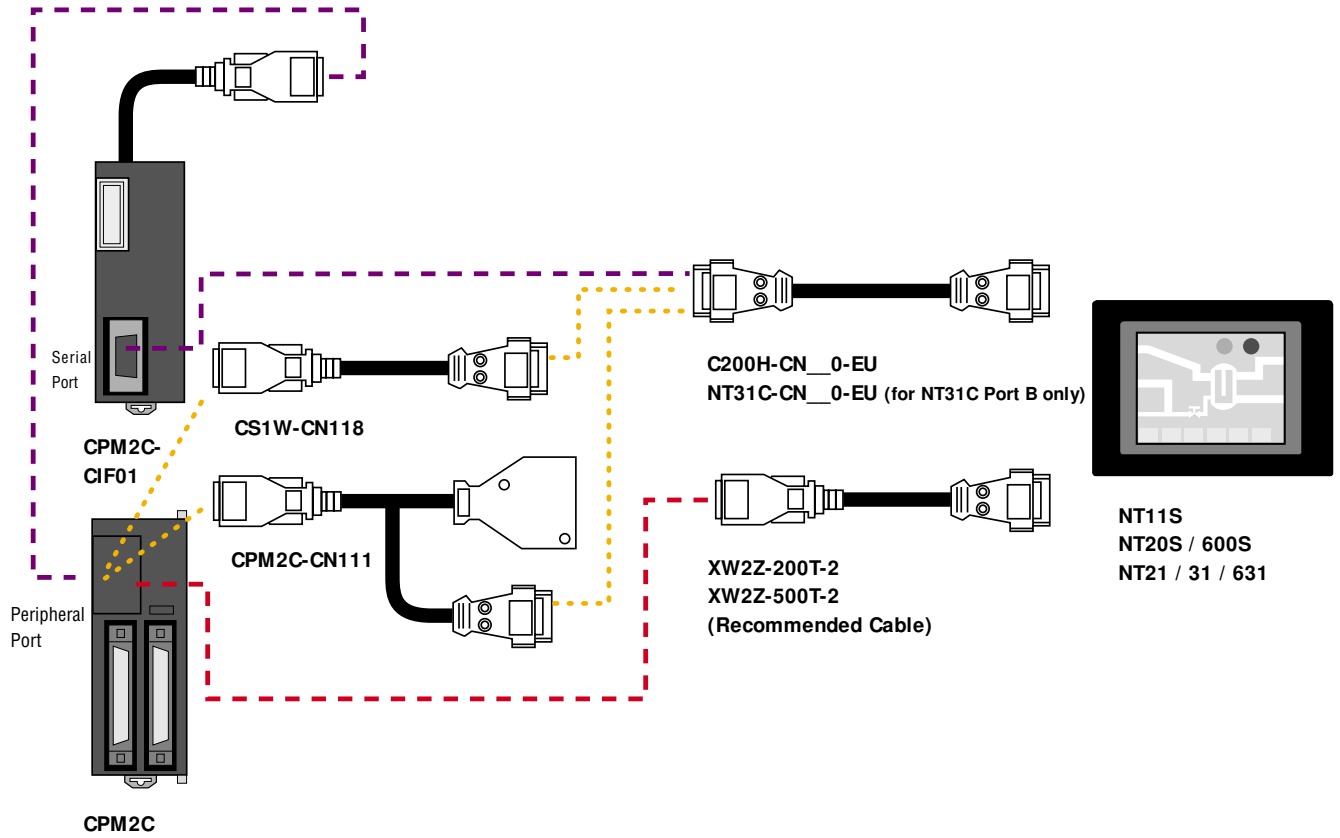

Cable Solutions for Omron PLCs

Operator Interface Terminals and CPM2B PLC

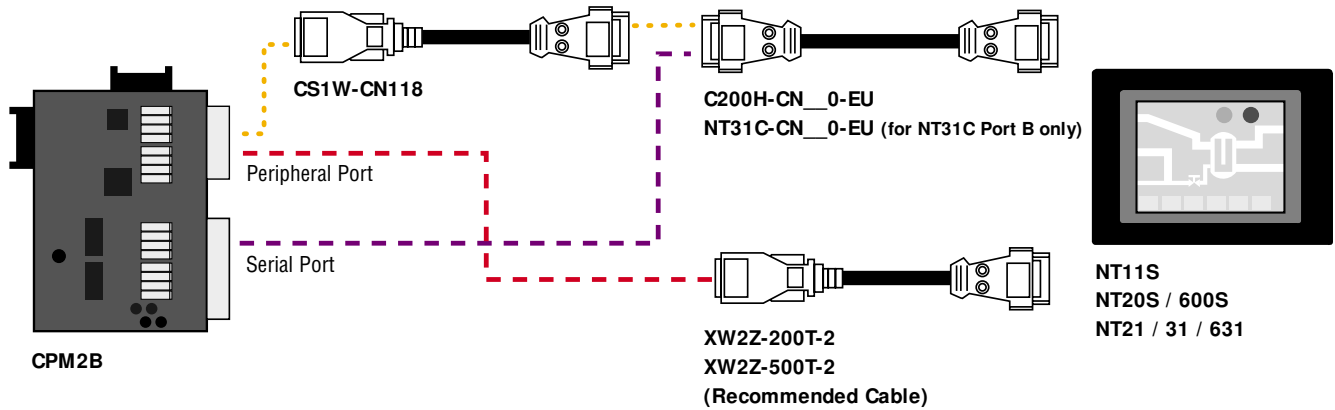

Operator Interface Terminals and CQM1H PLC

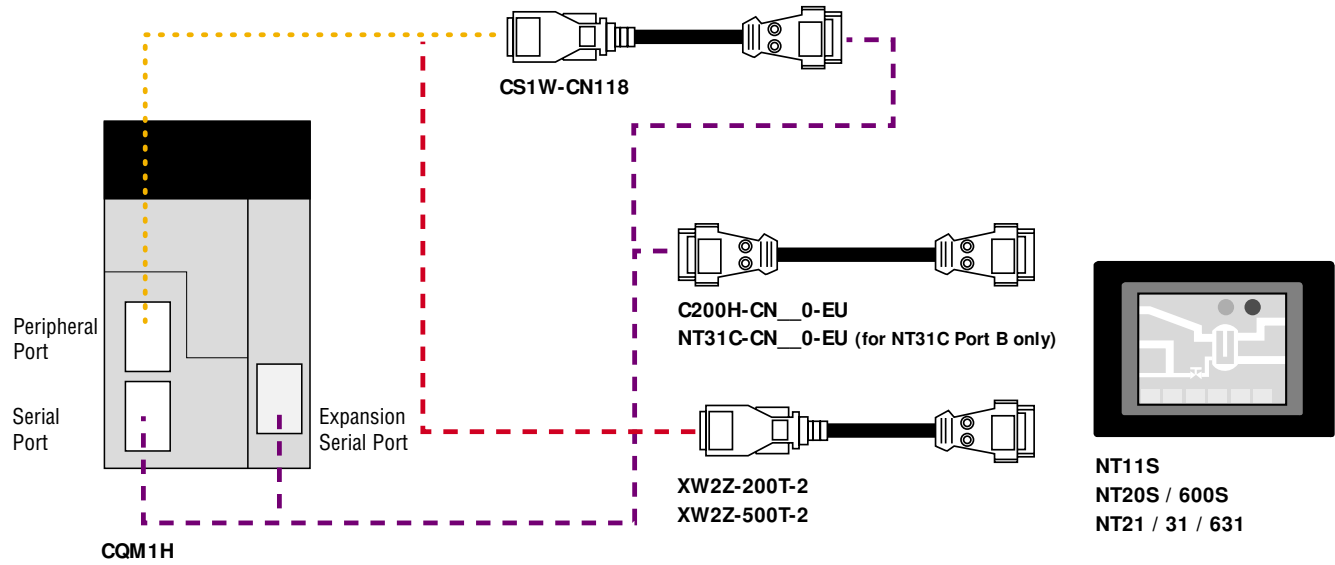

Cable Solutions for Omron PLCs

Operator Interface Terminals and CJ1 PLC

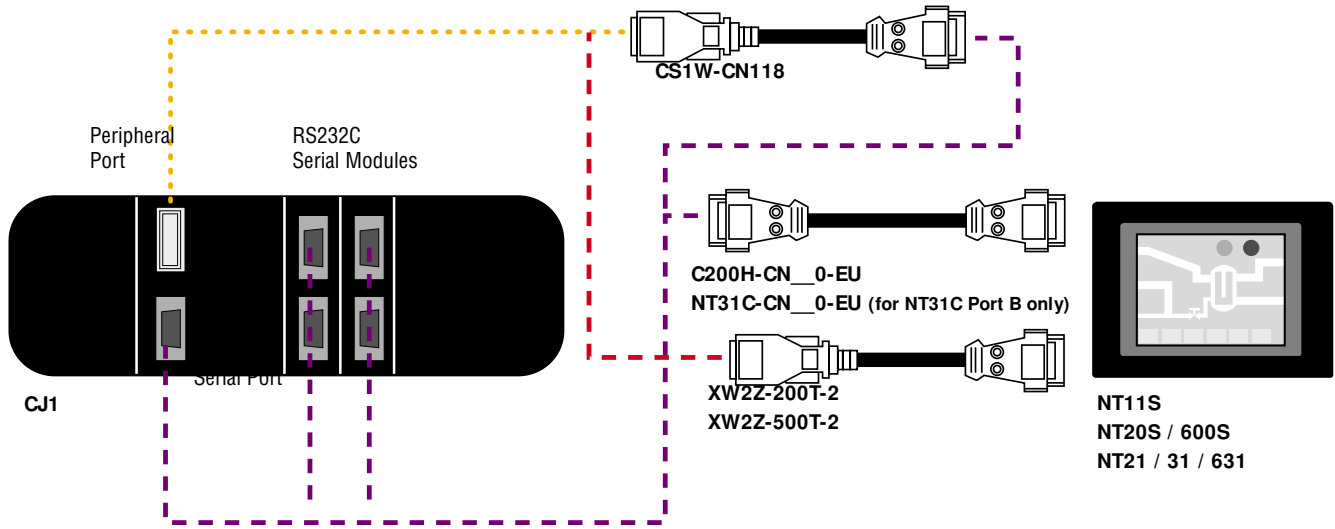

Operator Interface Terminals and CS1 PLC

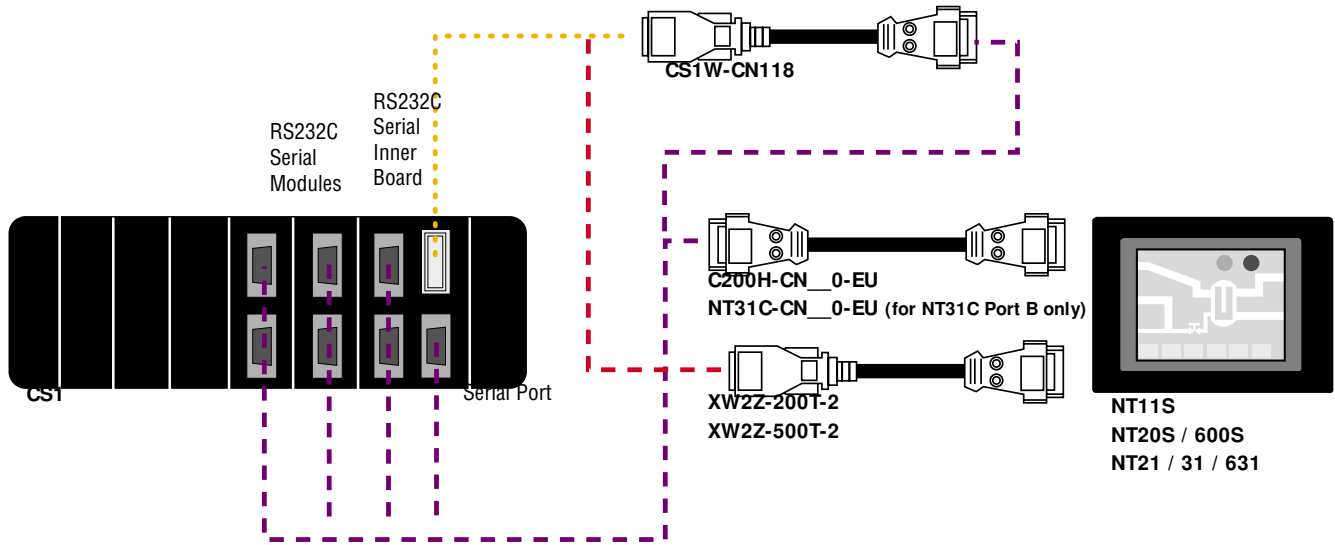

Cable Solutions for Omron PLCs

NT2S Message Display and Programmable Controllers

Peripheral port (Old type: C200H, SRM1, CPM2A, CPM1A)



NT2S-CN212 (2 m)
NT2S-CN215 (5 m)



NT2S-CN222-V1 (2 m)
NT2S-CN225-V1 (5 m)

Peripheral port (New type: CJ1, CS1, CQM1H, CPM2C)



NT2S-CN223-V1 (2 m)



NT2S-CN224-V1 (2 m)

NT2S-SF121

NT2S-SF122/123

NT2S-SF121

NT2S-SF122/123

NT2S Custom Cables

Any Omron
PLC Serial Port

RS232C

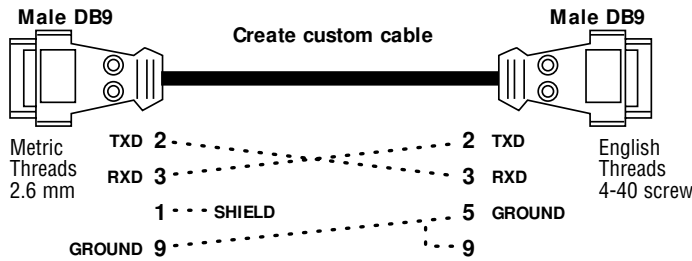

(Purchase Omron's C200H-CN32O-EU and short pins 5 and 9 on NT side as shown)

NT2S-SF121

Any Omron
PLC Serial Port

RS232C

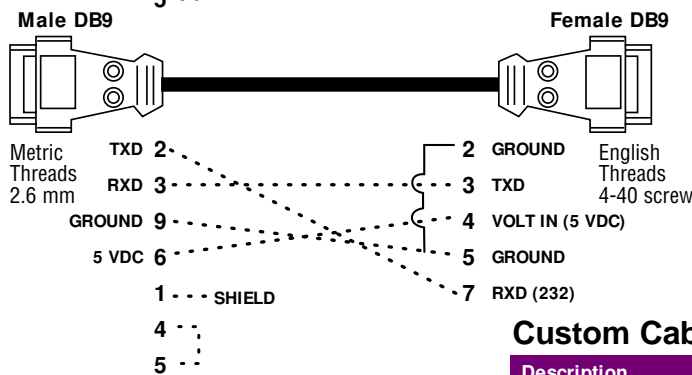

Custom Cable Ordering Information

Description	Part Number
Metric thread shell and screws - 2.6 mm	XM2S-0911
English thread shell and screws - 4-40 screw	XM2S-0913
Male connector	XM2A-0901
Female connector	XM2D-0901

Cable Solutions for Multi-Vendor PLCs

Allen Bradley MicroLogix 1200

An alternative cable configuration uses a custom RS-232 9-to-9 PIN cable connecting to the Allen-Bradley 1767-CBL-PM02(Series C). The diagram below shows the pinouts for the custom RS-232 cable:

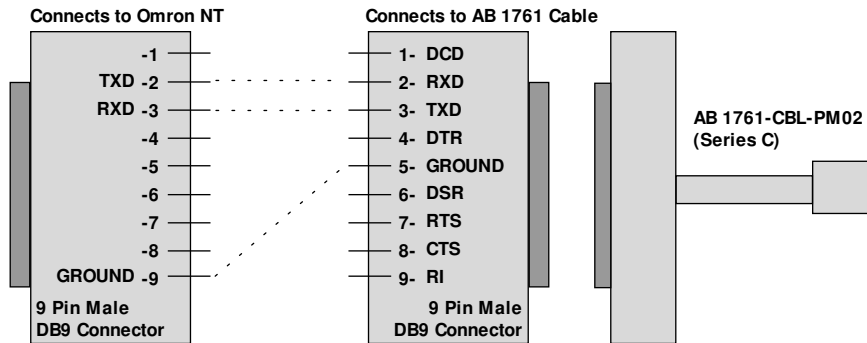

AB MicroLogix 1200 Communication Cables

1761-CBL-PM02(Series C) DB9 to 8 pin mini-din connector (order from AB)

Allen Bradley SLC 5/02

Communicates via AB's DF1 protocol. This PLC comes with only a DH-485 port. The Allen-Bradley 1747-KE module must be purchased to provide a serial connection on the SLC 5/02. Connect the communication cable from the NT to the serial port on the 1747-KE module.

AB SLC 5/02

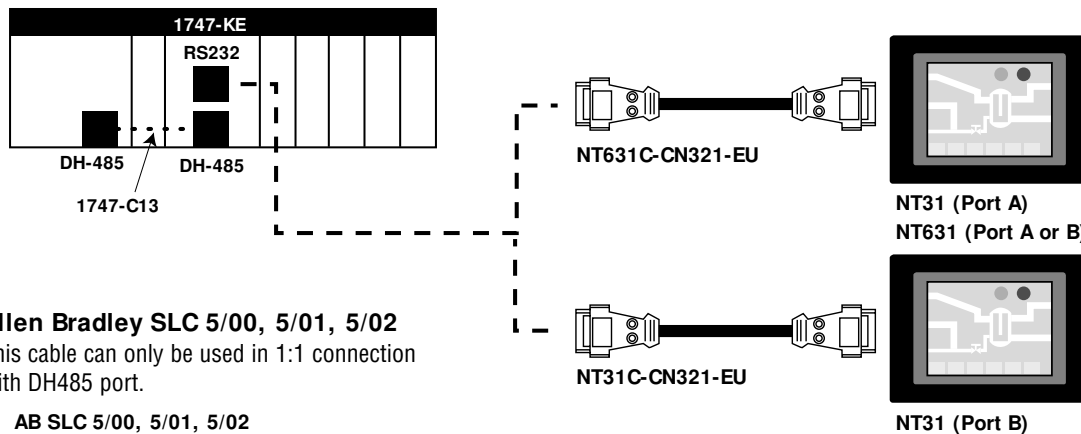

Allen Bradley SLC 5/00, 5/01, 5/02

This cable can only be used in 1:1 connection with DH485 port.

AB SLC 5/00, 5/01, 5/02

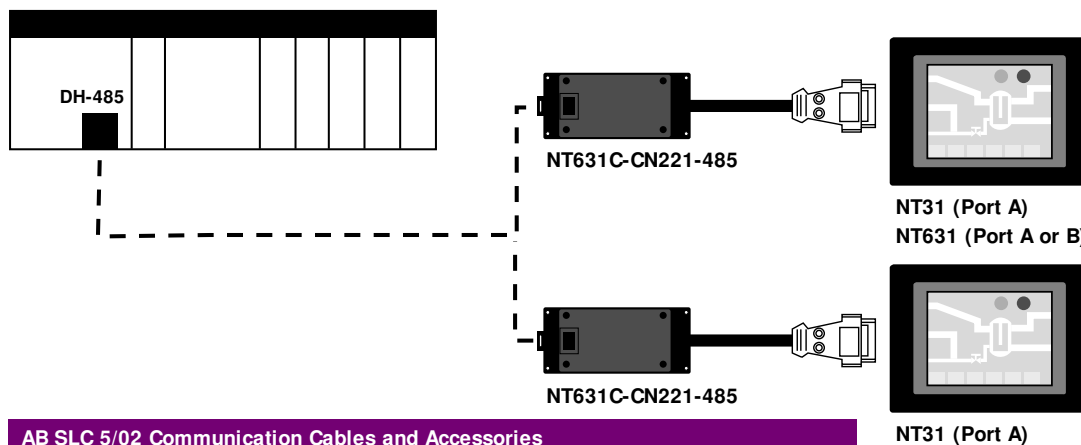

AB SLC 5/02 Communication Cables and Accessories

NT31C-CN321-EU	3.0 m cable, 25 to 9 pin, NT to AB SLC PLC
NT631C-CN321-EU	3.0 m cable, 9 to 9 pin, NT to AB SLC PLC
1747-KE	DB9 Serial Port Module (order from AB)
1747-C13	DH-485 module connection cable
V060-E1-2	Operation Manual – Multi-vendor Connection

Cable Solutions for Multi-Vendor PLCs

Allen Bradley SLC 5/03, 5/04, 5/05

Communicates via AB's DF1 protocol. Connect the communication cable from the NT to a serial port on the PLC using Omron cable part numbers.

AB SLC 5/03, 5/04, 5/05

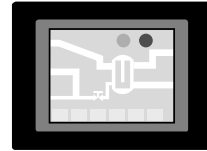
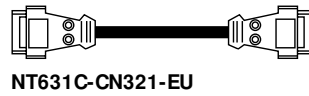
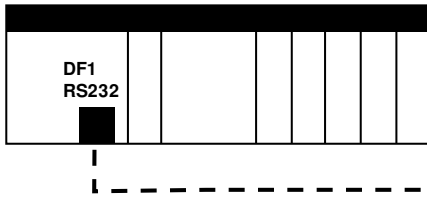

NT31 (Port A)
NT631 (Port A or B)

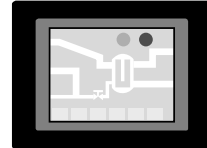

NT31 (Port B)

Allen Bradley SLC 5/03, 5/04, 5/05

This cable can only be used in 1:1 connection with DH485 port.

AB SLC 5/03, 5/04, 5/05

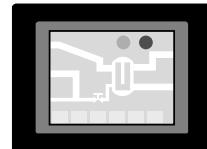
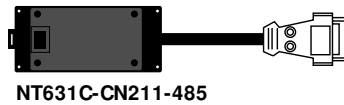
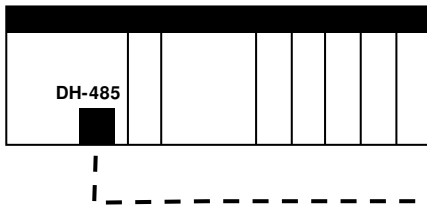

NT31 (Port A)
NT631 (Port A or B)

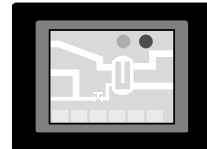
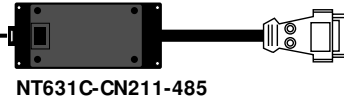

NT31 (Port A)

AB SLC 5/02 Communication Cables and Accessories

NT31C-CN321-EU	3.0 m cable, 25 to 9 pin, NT to AB SLC PLC
NT631C-CN321-EU	3.0 m cable, 9 to 9 pin, NT to AB SLC PLC
V060-E1-2	Operation Manual – Multi-vendor Connection

GE 90-20 and 90-30 Series PLCs

Communicates via GE's SNP-X protocol. The Omron NT is communicating RS-232, while the GE PLC uses RS-422. An RS232 to RS422 converter (HE693SNP232A) is needed to complete communications.

GE 90-20 and 90-30 Series

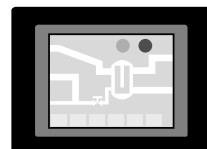
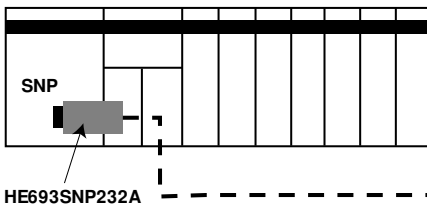

NT31 (Port A)
NT631 (Port A or B)

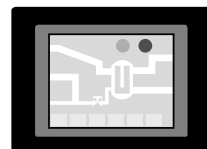

NT31 (Port B)

GE 90-20 and 90-30 Series Communication Cables and Accessories

NT31C-CN322-EU	3.0 m cable, 25 to 9 pin, NT to GE PLC
NT631C-CN322-EU	3.0 m cable, 9 to 9 pin, NT to GE PLC
HE693SNP232A	RS232 to RS422 adapter (order from GE)
V060-E1-2	Operation Manual – Multi-vendor Connection

Cable Solutions for Multi-Vendor PLCs

Siemens S7-300 and S7-400 Series PLCs

Communicates with Siemens HMI Adapter protocol. The Omron NT is communicating RS-232 to the Siemens HMI adapter, 6E57-972-OCA10-OXA0. The adapter is necessary to convert the HMI Adapter protocol into the Siemens proprietary MPI protocol.

Siemens S7-300 and S7-400 Series

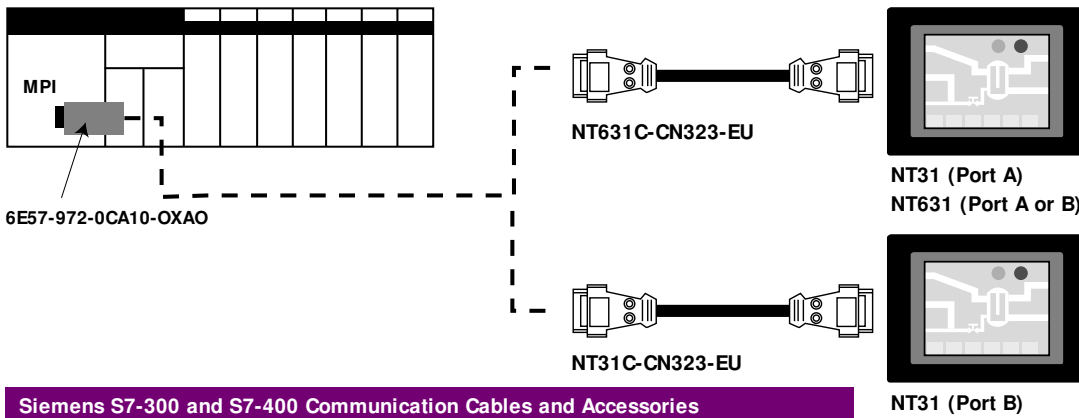

Siemens S7-300 and S7-400 Communication Cables and Accessories	
NT31C-CN323-EU	3.0 m cable, 25 to 9 pin, NT to Siemens PLC
NT631C-CN323-EU	3.0 m cable, 9 to 9 pin, NT to Siemens PLC
6E57-972-OCA10-OXA0	HMI Adapter for MPI protocol (order from Siemens)
V060-E1-2	Operation Manual – Multi-vendor Connection

Mitsubishi A-Series PLCs

Communicates using Mitsubishi's Computer Link protocol. The Omron NT and the Mitsubishi A-Series PLC are communicating using RS-232 communications. Communications can be RS-422 by using custom cables as specified in Operation Manual V042-E1-1.

Mitsubishi A-Series

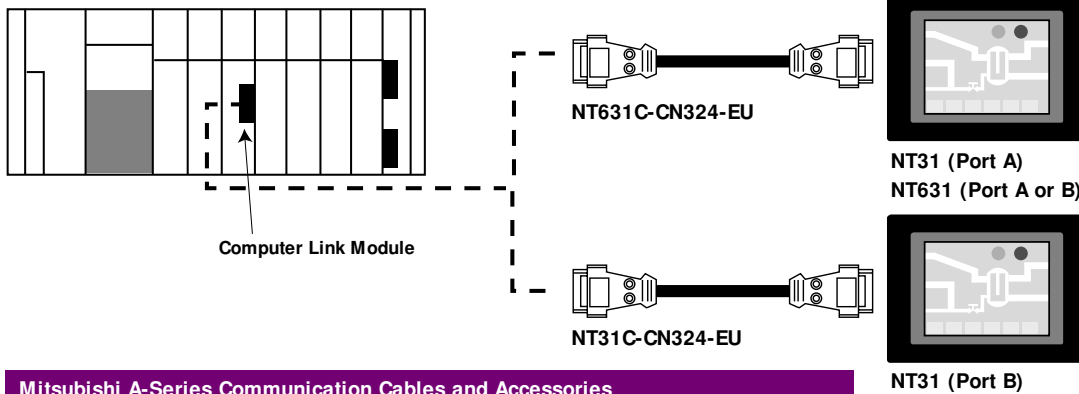

Mitsubishi A-Series Communication Cables and Accessories	
NT31C-CN324-EU	3.0 m cable, 25 to 9 pin, NT to Mits-A PLC
NT631C-CN324-EU	3.0 m cable, 9 to 9 pin, NT to Mits-A PLC
V042-E1-1	Operation Manual – PC (Mitsubishi) Connection

Cable Solutions for Multi-Vendor PLCs

Mitsubishi FX-Series PLCs

Communicates via Mitsubishi's Computer Link protocol. The Omron NT and Mitsubishi FX-Series PLC are communicating using RS422 communications. The NT31 cable connects from the 25-pin port B, while the NT631 connects from the RS422 terminal screws for Port B.

Mitsubishi FX-Series

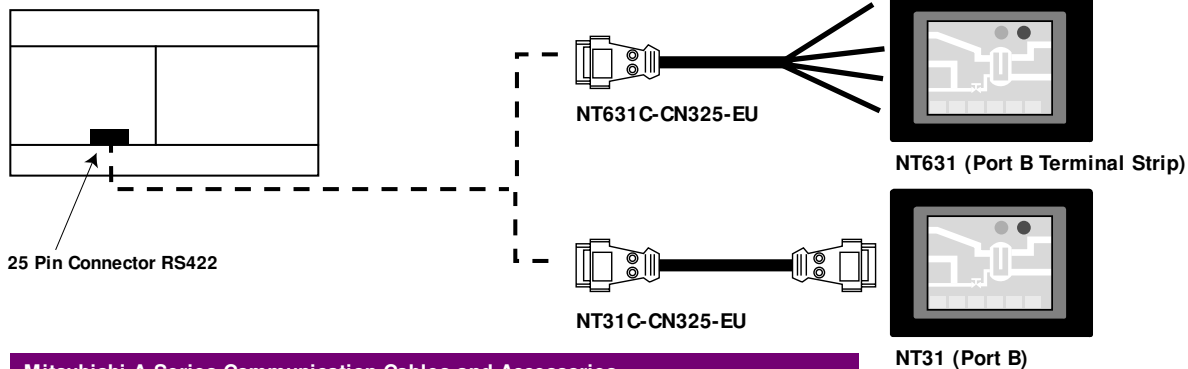

Mitsubishi A-Series Communication Cables and Accessories

NT31C-CN325-EU	3.0 m cable, 25 to 25 pin, NT to Mits-FX PLC
NT631C-CN325-EU	3.0 m cable, 4 Wires to 25 pin, NT to Mits-FX PLC
FX-20P-CADP	Cable for FX0 & FX0N PLC (buy from Mitsubishi)
V042-E1-1	Operation Manual – PC (Mitsubishi) Connection

Modicon TSX Micro 37-21/22 & Premium Series PLCs

For RS-232C connection:

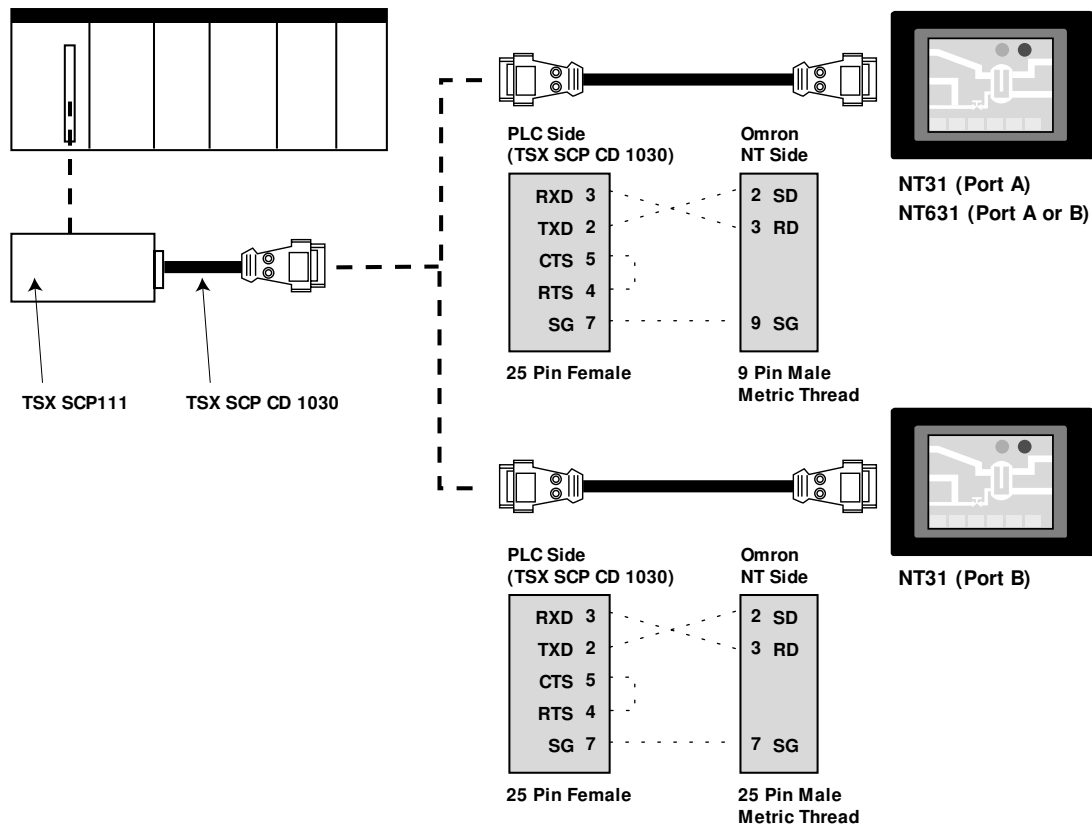

Modicon TSX Series Communication Cables and Accessories

TSX SCP111	Multi-protocol PCMCIA card for RS-232C
TSX SCP114	Multi-protocol PCMCIA card for RS-422A
TSX SCP CD 1030	Connecting cable for PCMCIA for RS-232C
TSX SCP CM 4030	Connecting cable for PCMCIA for RS-422A

Cable Solutions for Multi-Vendor PLCs

Modicon TSX Micro 37-21/22 & Premium Series PLCs

For RS-422A connection:

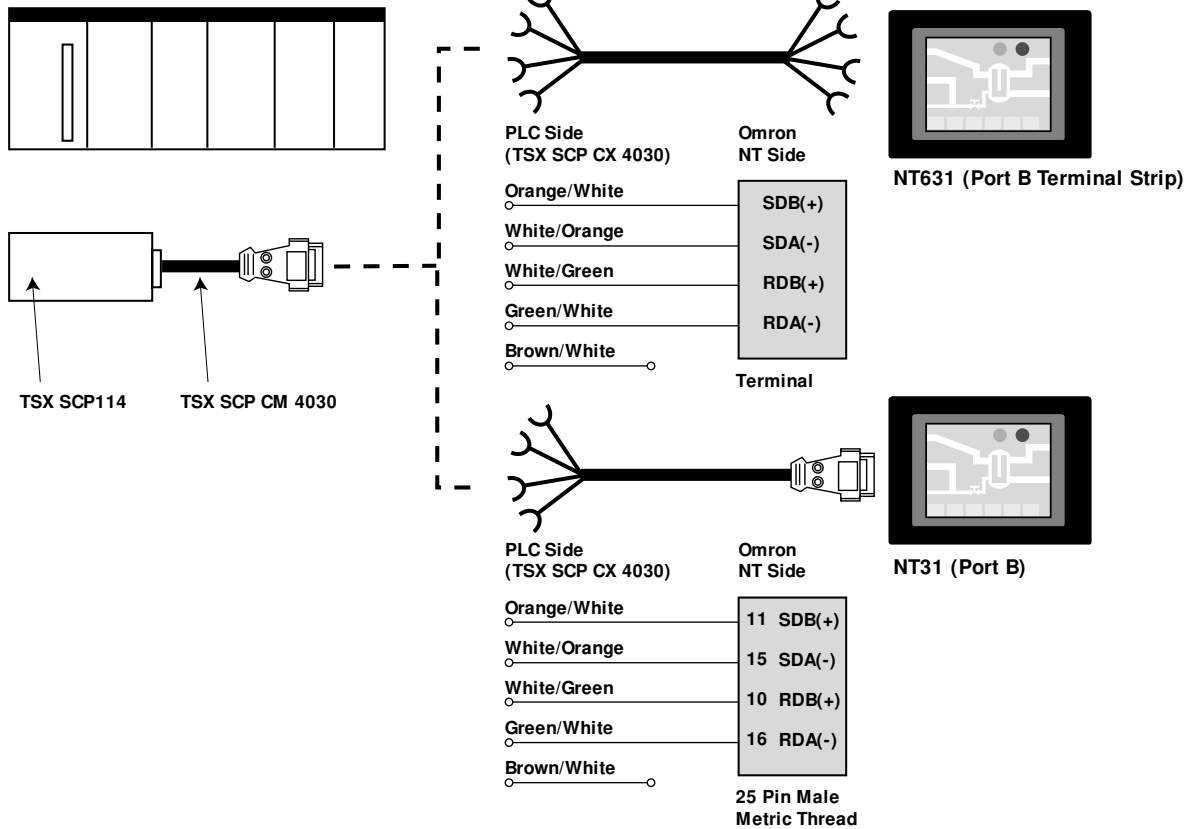

Modicon TSX Quantum Series PLCs

For RS-232C connection:

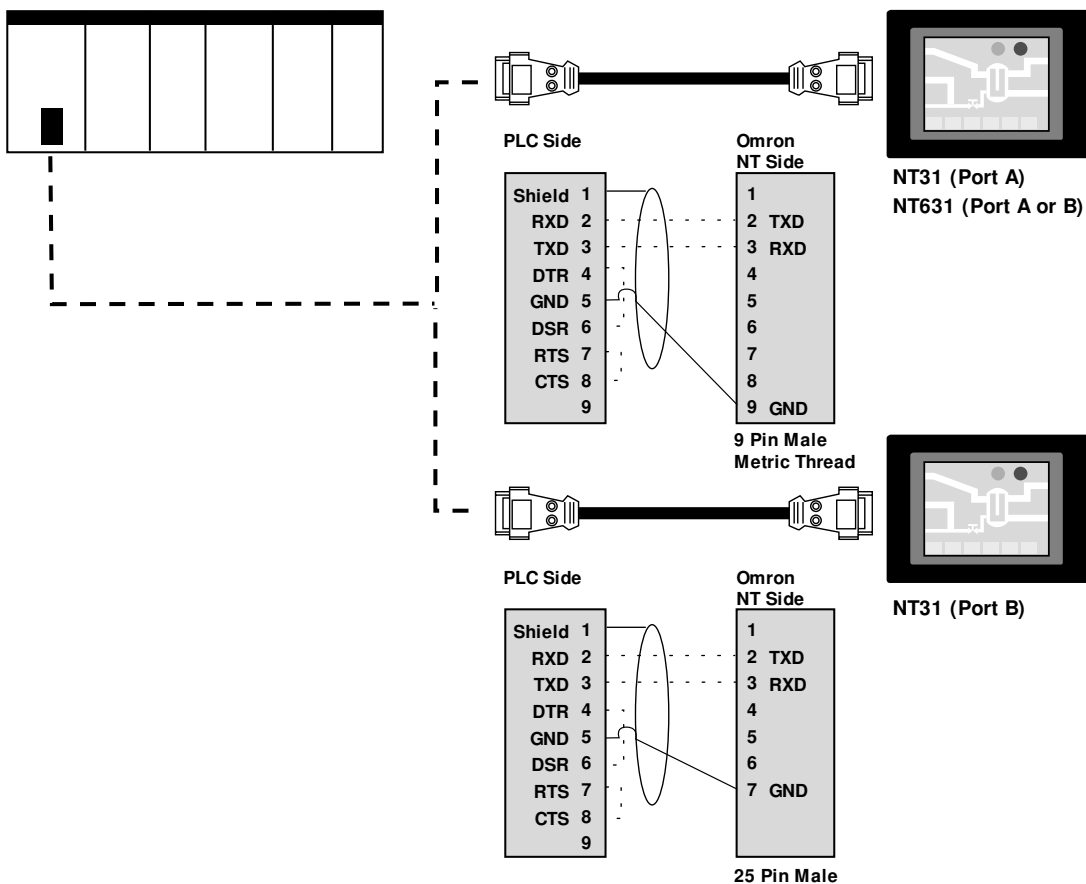



OMRON ELECTRONICS LLC

1 Commerce Drive
Schaumburg, IL 60173 USA
800.55.OMRON (66766)

OMRON CANADA, INC.

885 Milner Avenue
Scarborough, Ontario M1B 5V8
416.286.6465

OMRON ON-LINE

Global - <http://www.omron.com>
USA - <http://www.omron.com/oei>
Canada - <http://www.omron.com/oci>

UNITED STATES

To locate a Regional Sales Office, local Distributor or to obtain product information, call:

800.55.OMRON or 847.843.7900

CANADA REGIONAL SALES OFFICES

Ontario	Toronto	416.286.6465
	Kitchener	519.896.1144
	Kingston	613.376.3968
Quebec	Montreal	514.636.6676
British Columbia	Vancouver	604.522.8855
Alberta	Edmonton	403.440.0818
	Calgary	403.257.3095

BRAZIL SALES OFFICE

Sao Paulo 55.11.5564.6488

ARGENTINA SALES OFFICE

Cono Sur 54.114.787.1129

MEXICO SALES OFFICE - UNITED STATES

Florida 954.227.2121

MEXICO SALES OFFICE - MEXICO

Mexico, D.F. 555.534.1195 **Monterrey, N.L.** 818.377.4281