

1. INTRODUCTION

This instruction sheet covers mounting and wiring information for the AGASTAT\* GP and TR Series Control Relays (see Figure 1). Read these instructions thoroughly before mounting the relay.



Dimensions in this instruction sheet are in millimeters [with inches in brackets]. Figures are not drawn to scale.

2. DESCRIPTION

Each relay is an accurate instrument using a minimum of moving parts. When satisfactory performance cannot be restored, the unit should be returned to TE Connectivity for repair or replacement.

See Figure 2 for mounting hardware.

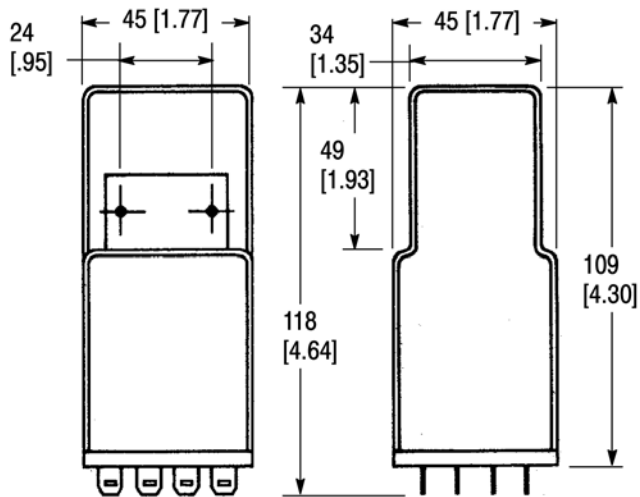

GP Series Terminal Diagram

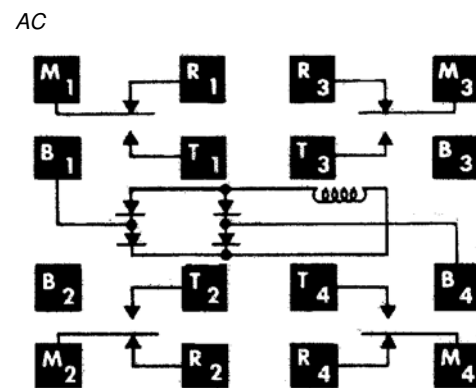
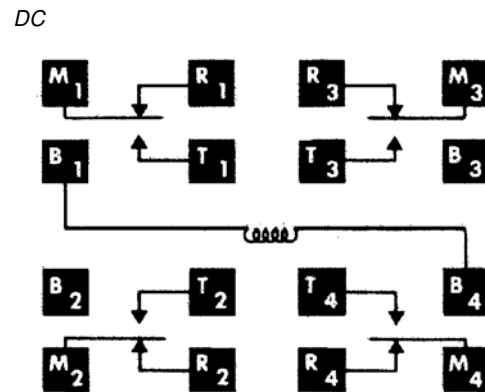

TR Series Terminal Diagram

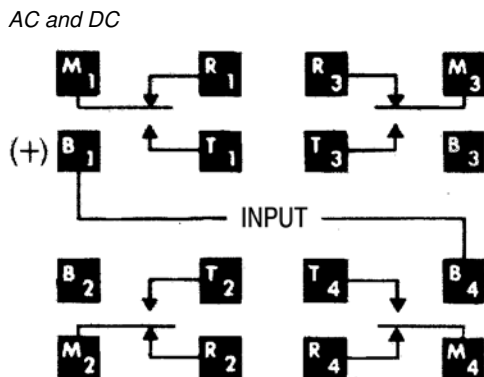

Figure 1

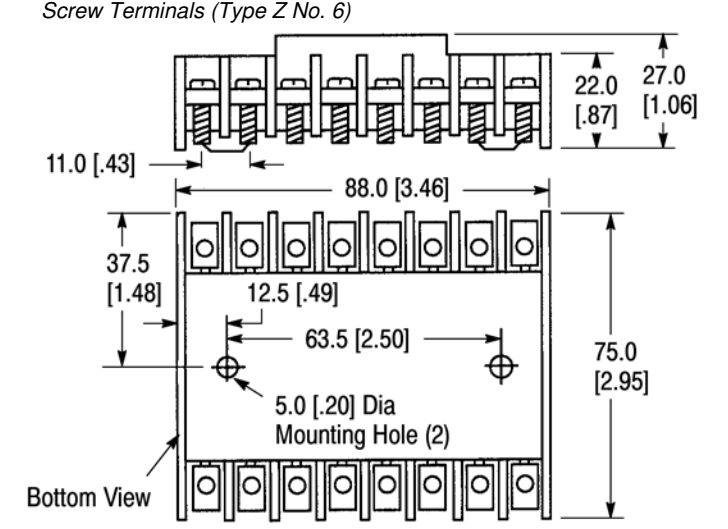
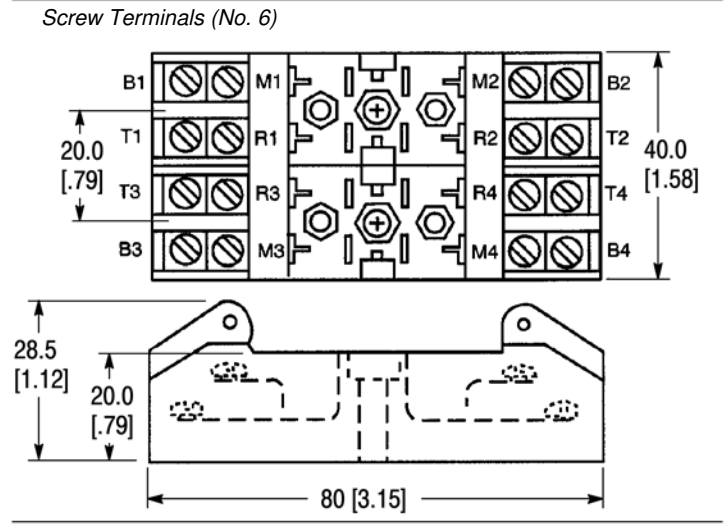
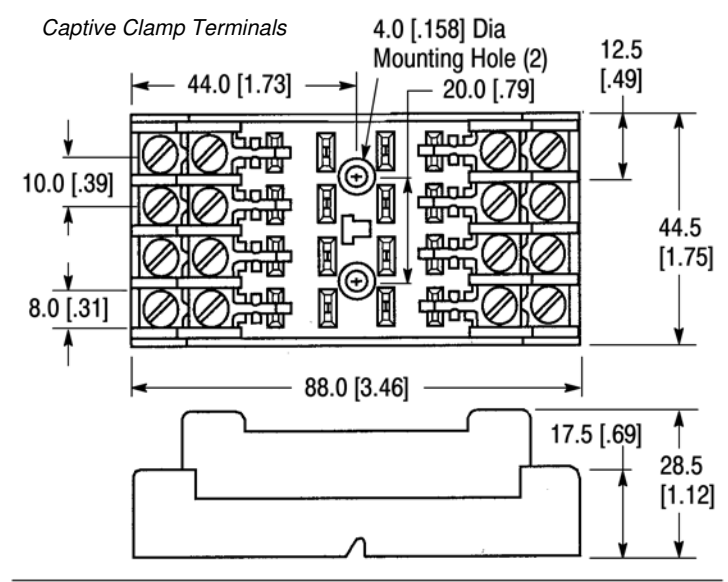
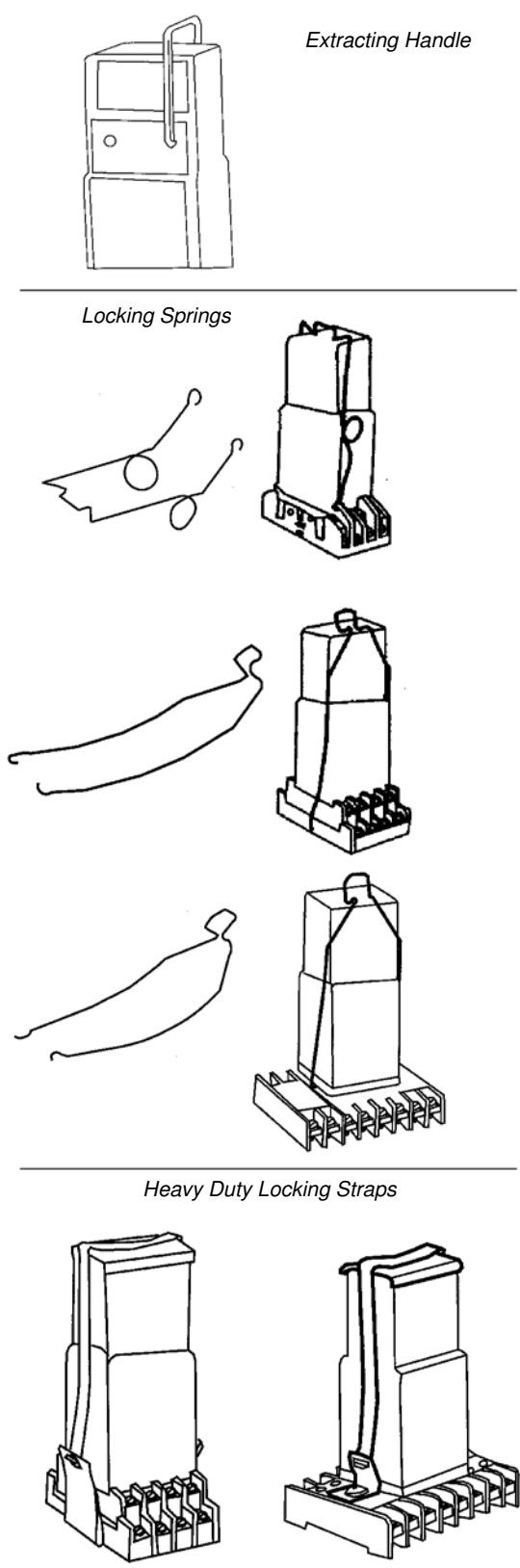

Figure 2

3. REVISION SUMMARY

Since the previous version of this document, the following changes were made:

- Removed references to ML series relays.
- Changed company name and logo.