

THIS DRAWING IS UNPUBLISHED. RELEASED FOR PUBLICATION BY AMP INCORPORATED. ALL INTERNATIONAL RIGHTS RESERVED. © COPYRIGHT 1989

REV	DATE	APPROV	DESCRIPTION
B	8/7/90	-	REDRAWN
C	8/21/91	-	REV PER ECN B04814
D	3-3-91	TMS	REV PER ECN B05049
E	6/22/92	TMS	REVISED PER ECN B06133

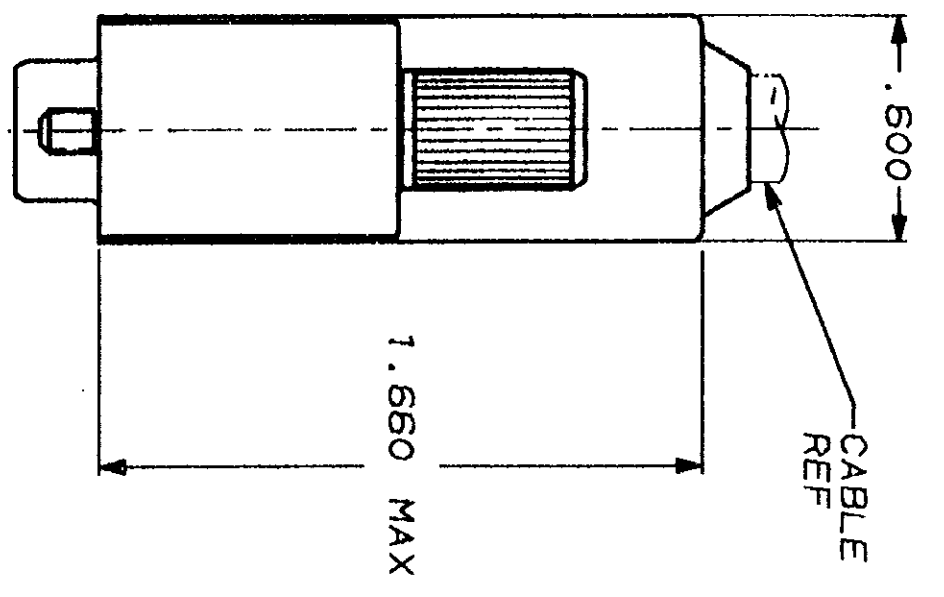
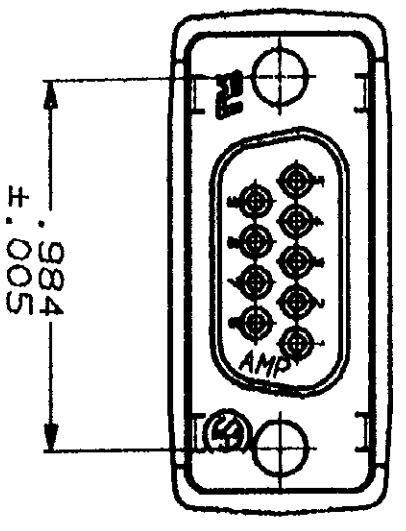
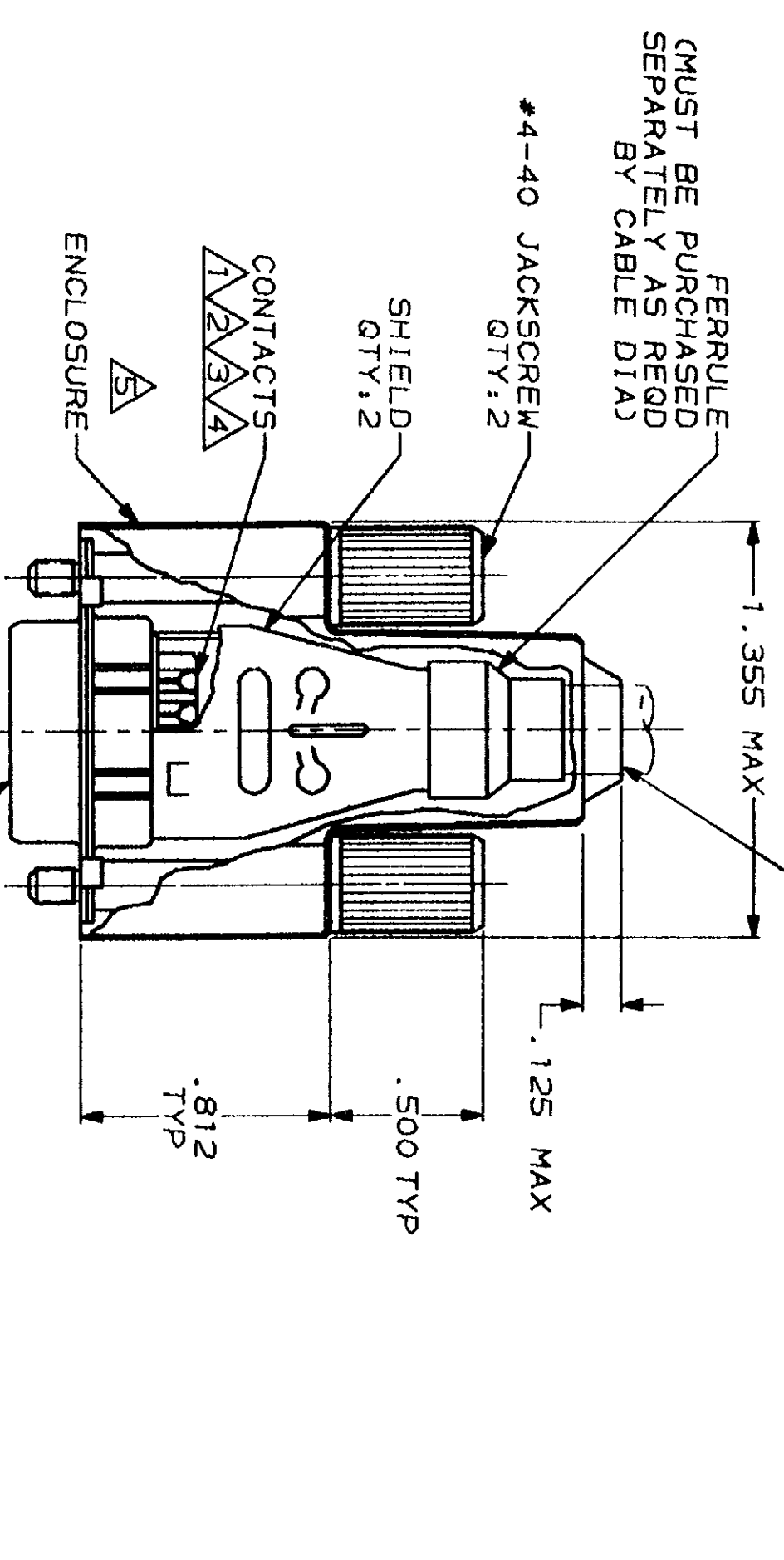

- 1 RCPT CONNECTOR FULLY LOADED WITH CONTACTS. ALL OTHER PARTS ARE SHIPPED UNASSEMBLED, EACH PART INDIVIDUALLY BULK PACKED.
- 2 PHOSPHOR BRONZE PER QQ-B-750.
- 3 SOLDER CUP WILL ACCOMMODATE 20 AWG MAX WIRE.
- 4 GOLD FLASH FOR LENGTH OF .150 MIN ON MATING END. .000150-.000300 TIN LEAD ON SOLDER END, ALL OVER .0000030 NICKEL ON ENTIRE CONTACT.
- 5 FLAME RETARDANT 94V-0 RATED THERMOPLASTIC, BLACK.
- 6 STEEL PER ASTM A109.
- 7 TIN PLATING PER MIL-T-10727.
- 8 ZINC PLATING PER ASTM B633, TYPE 11, CLASS SCI, BLACK CHROMATE.

DO NOT SCALE PRINT. UNLESS SPECIFIED DIMENSIONS IN INCHES TOLERANCES ON:	DR 6/7/90 A. STAB B6	NAME	AMP INCORPORATED Harrisburg, Pa. 17105
1 PLC DEC ± .020	CHK 8-31-90 J. McCLINTON	SIZE	FSCM NO 00779
2 PLC DEC ± .020	APPD 9-4-90 BOB TAYLOR	SCALE	2:1
3 PLC DEC ± .020	APPD 9-4-90 J. ASSINI	DRAWING NO	748047
MATERIAL: CONTACTS, SHIELDS, JACKSCREWS, ZINC ALLOY MOLDED PARTS	PRODUCT SPEC		
FINISH: CONTACTS, SHELLS & SHIELDS, JACKSCREWS	APPLICATION SPEC		
	WEIGHT		

CONTACT FINISH	748047-1
PART NUMBER	

748047

CUSTOMER DRAWING