

80極品に適用  
For 80Pin ITEM

80極品に適用  
For 80Pin ITEM

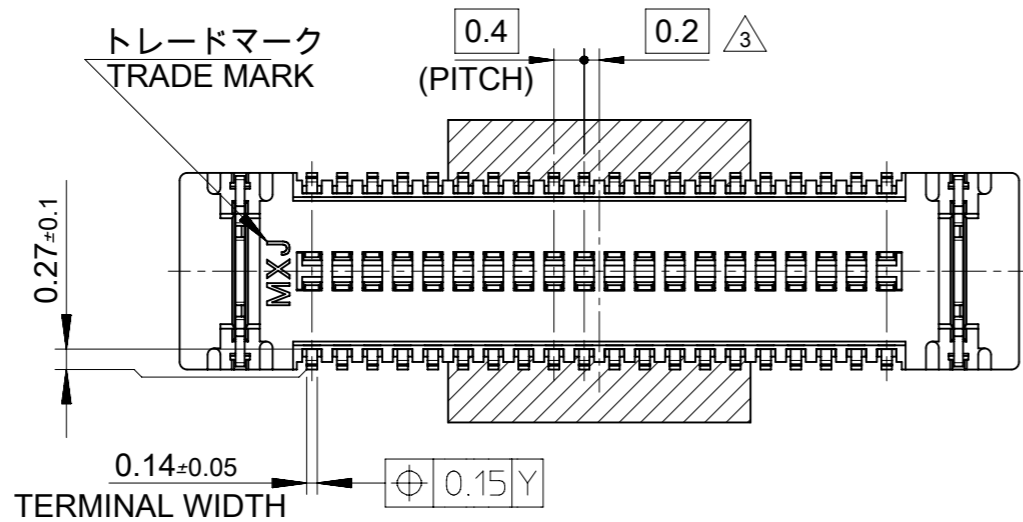
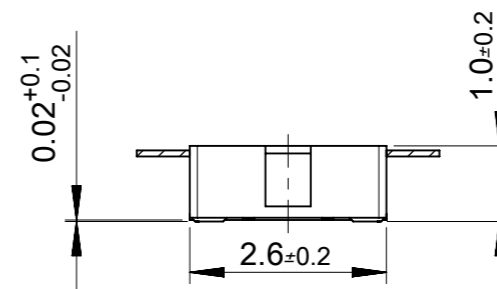
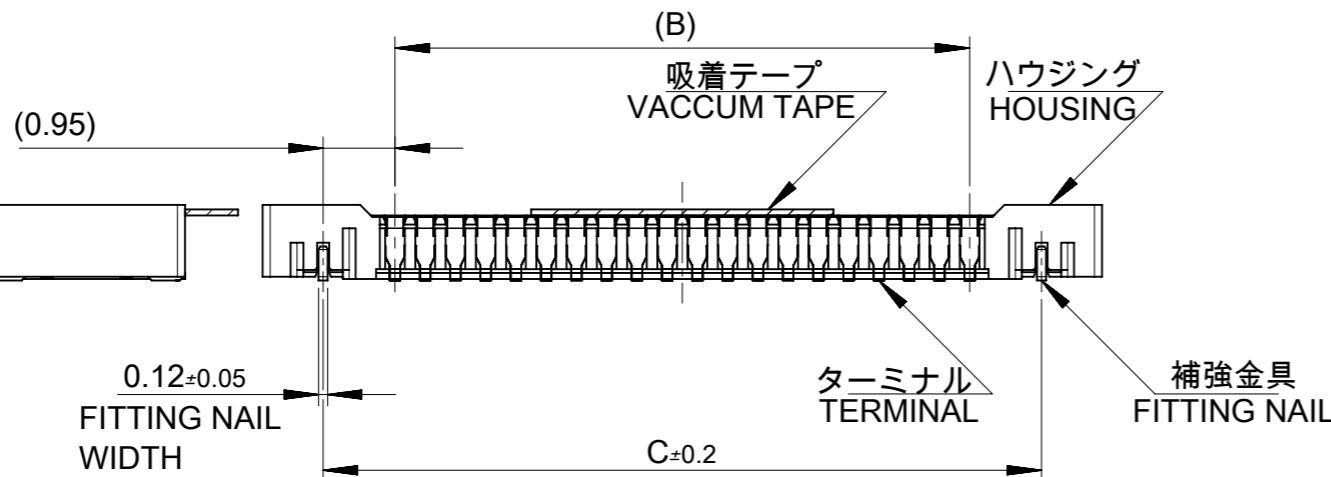
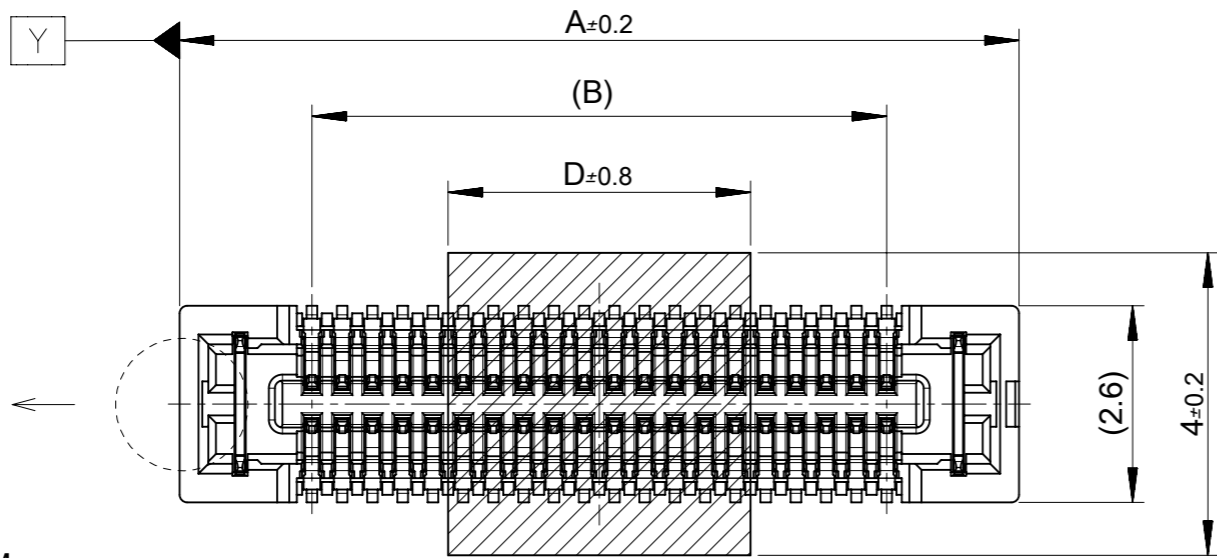

10.0	19.5	17.6	21.1	502426-9030	90
	17.5	15.6	19.1	502426-8030	80
	15.5	13.6	17.1	502426-7030	70
7.0	13.5	11.6	15.1	502426-6030	60
	11.5	9.6	13.1	502426-5030	50
4.0	9.5	7.6	11.1	502426-4030	40
	7.9	6.0	9.5	502426-3230	32
	7.5	5.6	9.1	502426-3030	30
3.4	6.7	4.8	8.3	502426-2630	26
	6.3	4.4	7.9	502426-2430	24
	5.9	4.0	7.5	502426-2230	22
2.4	5.5	3.6	7.1	502426-2030	20
	4.3	2.4	5.9	502426-1430	14
D	C	B	A	EMBOSSSED TAPE PACAKGE ORDER No.	CKT.

CONNECTOR SERIES No. : 502426-\*\*39

THIS DRAWING CONTAINS INFORMATION THAT IS PROPRIETARY TO MOLEX ELECTRONIC TECHNOLOGIES, LLC AND SHOULD NOT BE USED WITHOUT WRITTEN PERMISSION		CURRENT REV DESC: REVISED		<b>molex</b>		
DIMENSION UNITS mm	SCALE 10:1					0.4 B-TO-B CONN. HGT=1.0 W=2.6 REC ASSY WITH TAPE
GENERAL TOLERANCES (UNLESS SPECIFIED)		EC NO: 641594		PRODUCT CUSTOMER DRAWING		
ANGULAR TOL	± °	DRWN: TNAKAGAWA01 2020/07/16		DOCUMENT NUMBER SD-502426-003		
4 PLACES	±	CHK'D: HSHIMOYAMA 2020/10/16		DOC TYPE DOC PART REVISION PSD 001 G		
3 PLACES	±	APPR: SHOSHIKAWA 2020/10/17				
2 PLACES	±	INITIAL REVISION:				
1 PLACE	±	DRWN: RTAKEUCHI 2007/12/26				
0 PLACES	±	APPR: MSASAO 2007/12/27				
DRAFT WHERE APPLICABLE MUST REMAIN WITHIN DIMENSIONS		THIRD ANGLE PROJECTION	DRAWING A3-SIZE	SERIES 502426	MATERIAL NUMBER SEE TABLE	CUSTOMER GENERAL

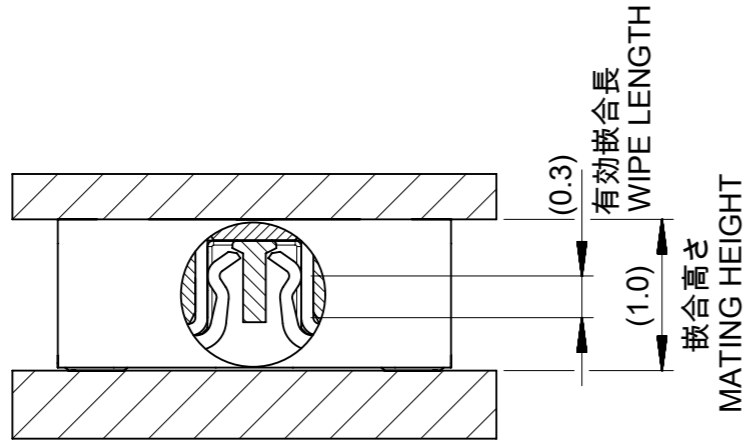

嵌合断面図 (参考)  
MATED DRAWING (REFERENCE)

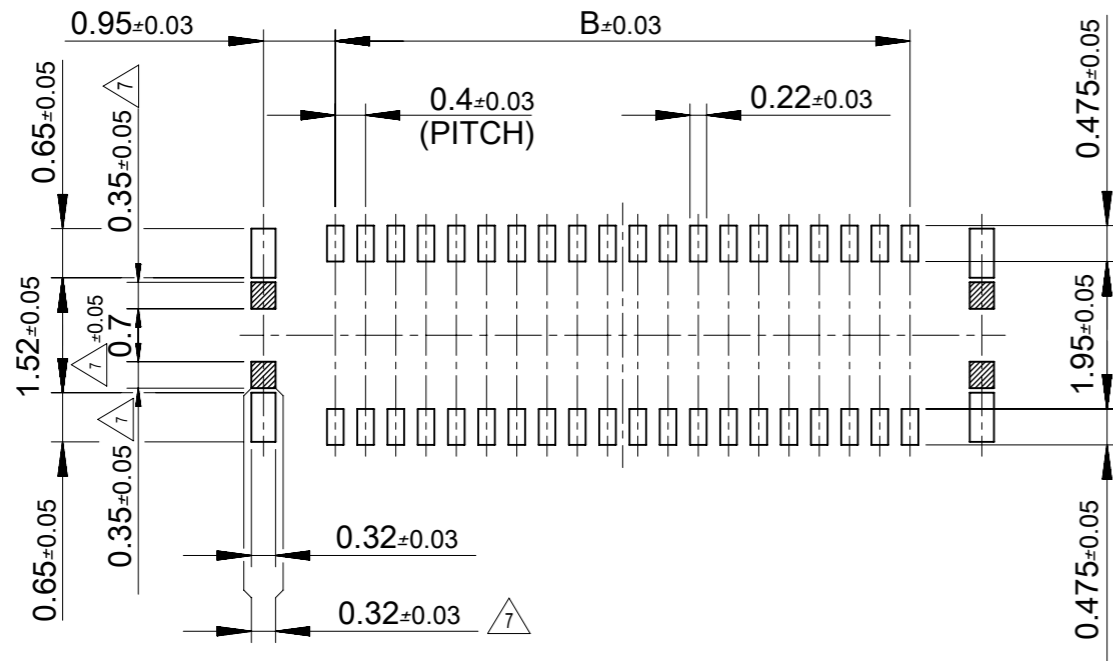

P.C. BOARD PATTERN LAYOUT  
(REFERENCE)

注記 NOTE

1. 使用材料 MATERIAL  
ハウジング: 液晶ポリマー (LCP) ガラス充填 UL94V-0 (黒)  
HOUSING: LIQUID CRYSTAL POLYMER (GLASS FILLED) UL94V-0 (COLOR: BLACK)  
ターミナル: リン青銅 (t=0.1)  
TERMINAL: PHOSPHOR BRONZE (t=0.1)  
金具: リン青銅 (t=0.12)  
FITTING NAIL: PHOSPHOR BRONZE (t=0.12)  
吸着テープ: ポリイミド  
VACUUM TAPE: POLYIMIDE
  2. メッキ仕様 PLATING  
ターミナル TERMINAL  
コンタクト部: 金メッキ0.1マイクロメートル以上  
CONTACT AREA: GOLD 0.1 MICROMETER MINIMUM.  
テール部: 金メッキ0.05マイクロメートル以上  
TAIL AREA: GOLD 0.05 MICROMETER MINIMUM.  
下地メッキ: ニッケルメッキ 1.0マイクロメートル以上  
UNDER PLATING: NICKEL 1.0MICROMETER MINIMUM  
※コンタクト部とテール部はニッケルメッキによって分断されている金メッキです。  
DIVIDE INTO PARTS THE GOLD PLATING OF THE CONTACT AND THE TAIL PART BY THE NICKEL PLATING.  
金具 FITTING NAIL  
フラッシュ金メッキ  
FLASH Au PLATING  
下地メッキ: ニッケルメッキ 1.0マイクロメートル以上  
UNDER PLATING: NICKEL 1.0MICROMETER MINIMUM
- △3 (全極数 / 2) = 偶数の場合に適用。  
APPLY FOR (CIRCUIT/2)=EVEN.
4. 嵌合相手: 502430シリーズ  
MATE WITH: 502430 SERIES.
  5. テール平坦度は、0.08以下  
TAIL COPLANARITY TO BE 0.08 MAXIMUM  
テール及び金具の平坦度は、0.1以下  
TAIL AND FITTING NAIL COPLANARITY TO BE 0.1 MAXIMUM.
  6. ELV 及び RoHS適合品  
ELV AND RoHS COMPLIANT.
- △7 斜線部はパターン書込み禁止範囲と半田禁止範囲を示す。  
ただし、斜線部に補強金具と同一配線を配置する場合はレジストを施し、この部分に半田は無きこと。  
NO PATTERN CIRCUIT AND NO SOLDER ALLOWED IN THE SHADED AREA.  
HOWEVER, IF NEEDED TO ADD A TRACE OF THE SAME CIRCUIT, PUT THE SOLDER-RESIST, YET NO SOLDER ALLOWED IN THE AREA.

THIS DRAWING CONTAINS INFORMATION THAT IS PROPRIETARY TO MOLEX ELECTRONIC TECHNOLOGIES, LLC AND SHOULD NOT BE USED WITHOUT WRITTEN PERMISSION		CURRENT REV DESC: REVISED		<b>molex</b>	
DIMENSION UNITS	SCALE				
mm	10:1				
GENERAL TOLERANCES (UNLESS SPECIFIED)		EC NO: 641594		PRODUCT CUSTOMER DRAWING	
ANGULAR TOL	± °	DRWN: TNAKAGAWA01 2020/07/16		DOCUMENT NUMBER	
4 PLACES	±	CHK'D: HSHIMOYAMA 2020/10/16		SD-502426-003	
3 PLACES	±	APPR: SHOSHIKAWA 2020/10/17		DOC TYPE	
2 PLACES	±	INITIAL REVISION:		DOC PART	
1 PLACE	±	DRWN: RTAKEUCHI 2007/12/26		REVISION	
0 PLACES	±	APPR: MSASAO 2007/12/27		G	
DRAFT WHERE APPLICABLE MUST REMAIN WITHIN DIMENSIONS	THIRD ANGLE PROJECTION	DRAWING	SERIES	MATERIAL NUMBER	CUSTOMER
		A3-SIZE	502426	SEE SHEET 1	GENERAL
				SHEET NUMBER	
				2 OF 2	

注記 NOTES

1. 製品詳細寸法については製品単体図面を参照下さい。  
DETAIL DIMENSION, SEE PRODUCT DRAWING.
2. 梱包数量 : 3000 個 / リール  
NUMBER OF CONNECTORS : 3000PCS/REEL
3. リードテープ長さ LEAD TAPE LENGTH

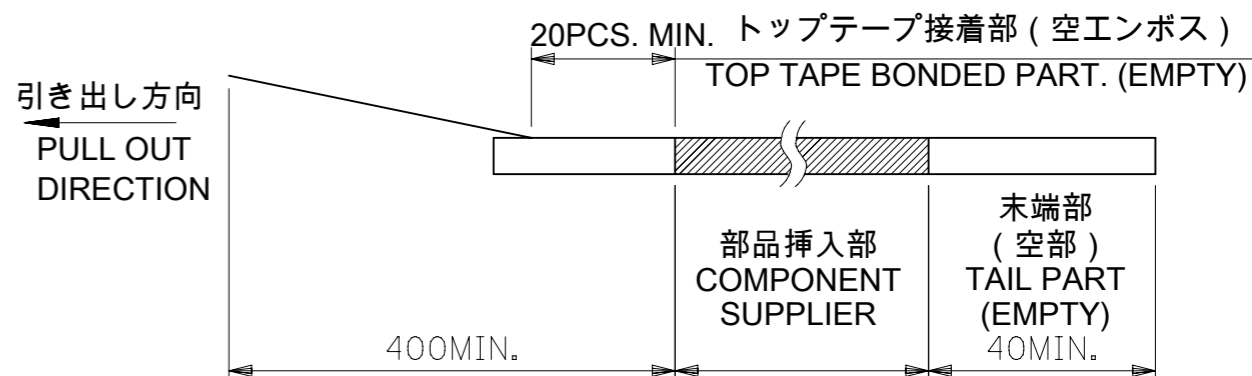

4. 材料 MATERIAL

キャリアテープ (CARRIER TAPE) : ポリスチレン (POLYSTYRENE)  
 トップテープ (TOP TAPE) : PET , PE , PEF  
 リール(REEL) : ポリスチレン (PS) <リサイクル材を含む>  
 POLYSTYRENE (PS) <RECYCLE MATERIAL CONTAINED>

5. ELV 及び RoHS適合品

ELV AND RoHS COMPLIANT

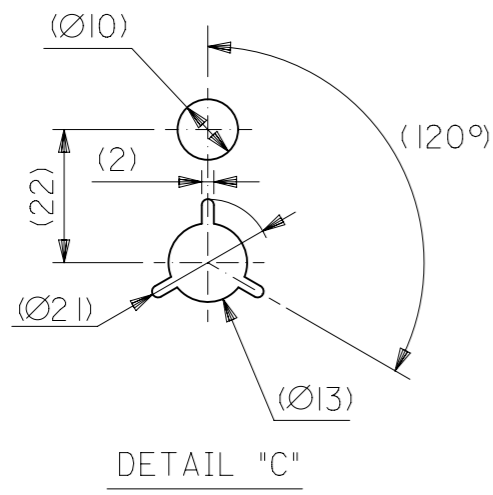
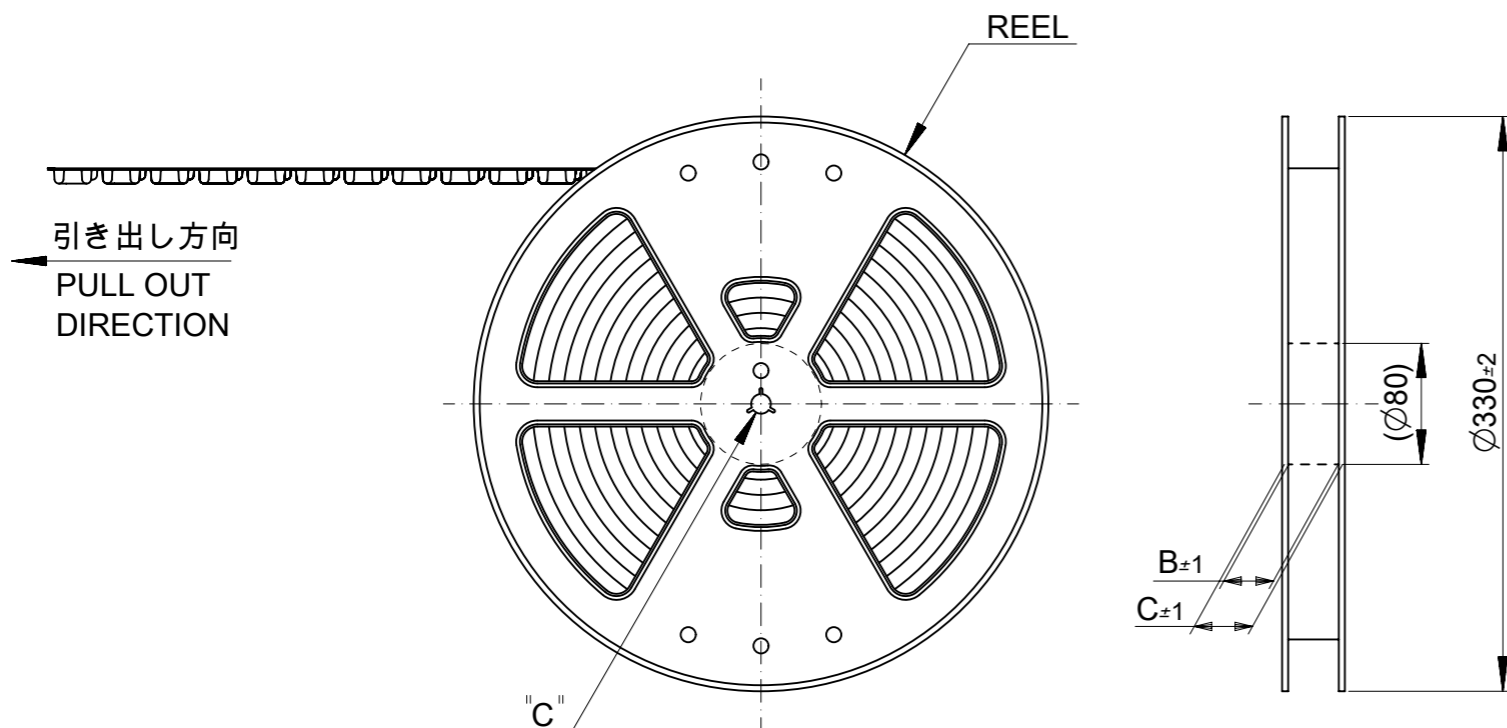

MODEL NO. 502426-\*\*30

THIS DRAWING CONTAINS INFORMATION THAT IS PROPRIETARY TO MOLEX ELECTRONIC TECHNOLOGIES, LLC AND SHOULD NOT BE USED WITHOUT WRITTEN PERMISSION		CURRENT REV DESC: REVISED		<b>molex</b>	
DIMENSION UNITS	SCALE				
mm	NTS			PRODUCT CUSTOMER DRAWING	
GENERAL TOLERANCES (UNLESS SPECIFIED)		EC NO: 641594		DOCUMENT NUMBER	
ANGULAR TOL	± °	DRWN: TNAKAGAWA01 2020/07/16		SD-502426-004	
4 PLACES	±	CHK'D: HSHIMOYAMA 2020/10/16		DOC TYPE	DOC PART
3 PLACES	±	APPR: SHOSHIKAWA 2020/10/17		PSD	001
2 PLACES	±	INITIAL REVISION:		REVISION	F
1 PLACE	±	DRWN: RTAKEUCHI 2007/12/26			
0 PLACES	±	APPR: MSASAO 2007/12/27			
DRAFT WHERE APPLICABLE MUST REMAIN WITHIN DIMENSIONS		THIRD ANGLE PROJECTION	DRAWING	SERIES	MATERIAL NUMBER
			A3-SIZE	502426	SEE SHEET 2-5
				CUSTOMER	SHEET NUMBER
				GENERAL	1 OF 4

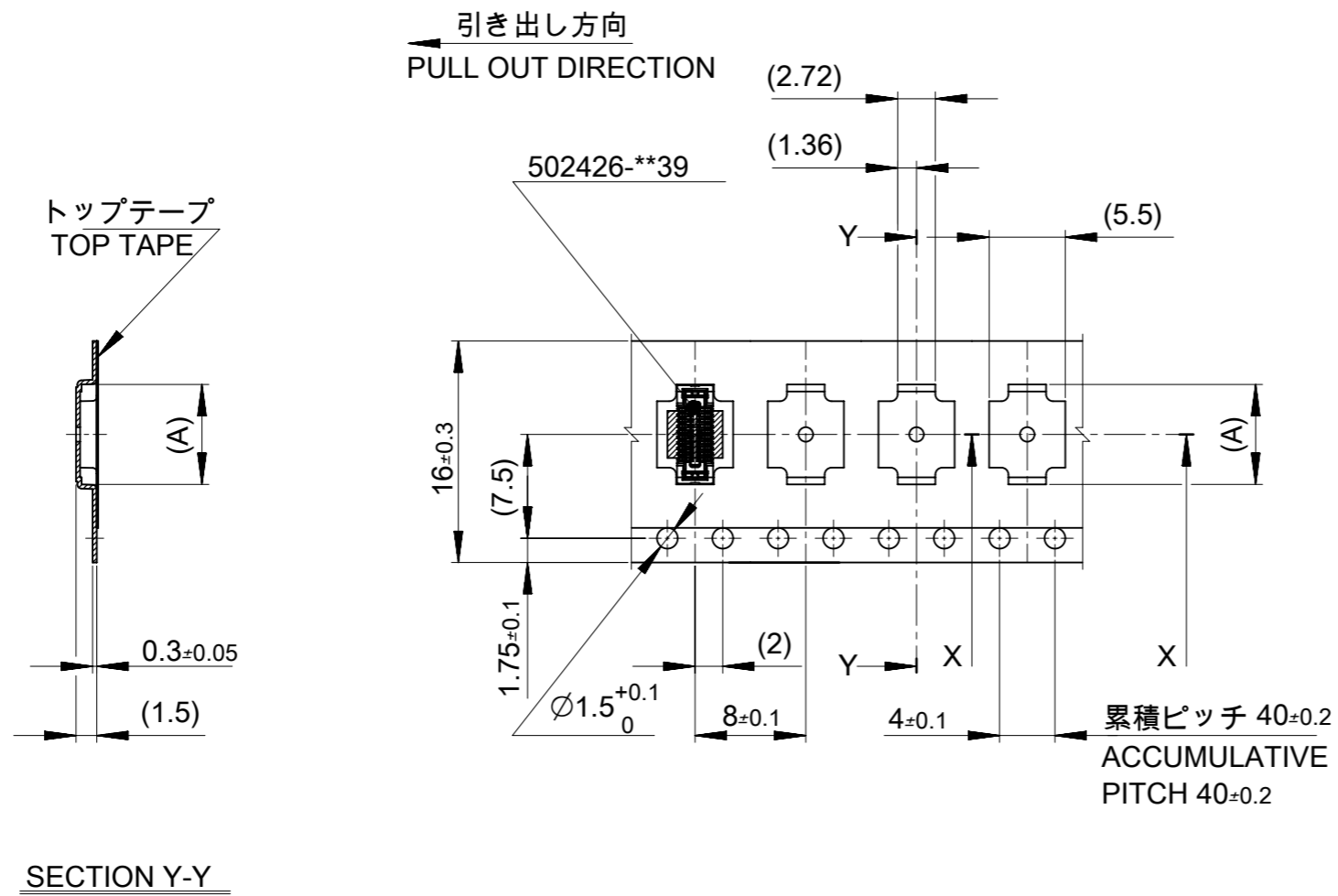

16mm 幅キャリアテープ  
16mm WIDTH CARRIER TAPE

16	21.4	17.4	8.42	502426-2630	26		
			8.02	502426-2430	24		
			7.62	502426-2230	22		
			7.22	502426-2030	20		
			6.02	502426-1430	14		
キャリアテープ幅 CARRIER TAPE WIDTH			C	B	(A)	MATERIAL No.	CKT.
MODEL No.				502426-**30			

THIS DRAWING CONTAINS INFORMATION THAT IS PROPRIETARY TO MOLEX ELECTRONIC TECHNOLOGIES, LLC AND SHOULD NOT BE USED WITHOUT WRITTEN PERMISSION

DIMENSION UNITS mm	SCALE NTS	CURRENT REV DESC: REVISED		<b>molex</b>		
GENERAL TOLERANCES (UNLESS SPECIFIED)		EC NO: 641594				
ANGULAR TOL ± °		DRWN: TNAKAGAWA01 2020/07/16		PRODUCT CUSTOMER DRAWING		
4 PLACES ±		CHK'D: HSHIMOYAMA 2020/10/16		DOCUMENT NUMBER		
3 PLACES ±		APPR: SHOSHIKAWA 2020/10/17		SD-502426-004		
2 PLACES ±		INITIAL REVISION:		DOC TYPE	DOC PART	REVISION
1 PLACE ±		DRWN: RTAKEUCHI 2007/12/26		PSD	001	F
0 PLACES ±		APPR: MSASAO 2007/12/27		SHEET NUMBER		
DRAFT WHERE APPLICABLE MUST REMAIN WITHIN DIMENSIONS	THIRD ANGLE PROJECTION	DRAWING	SERIES	MATERIAL NUMBER	CUSTOMER	
		A3-SIZE	502426	SEE TABLE	GENERAL	2 OF 4

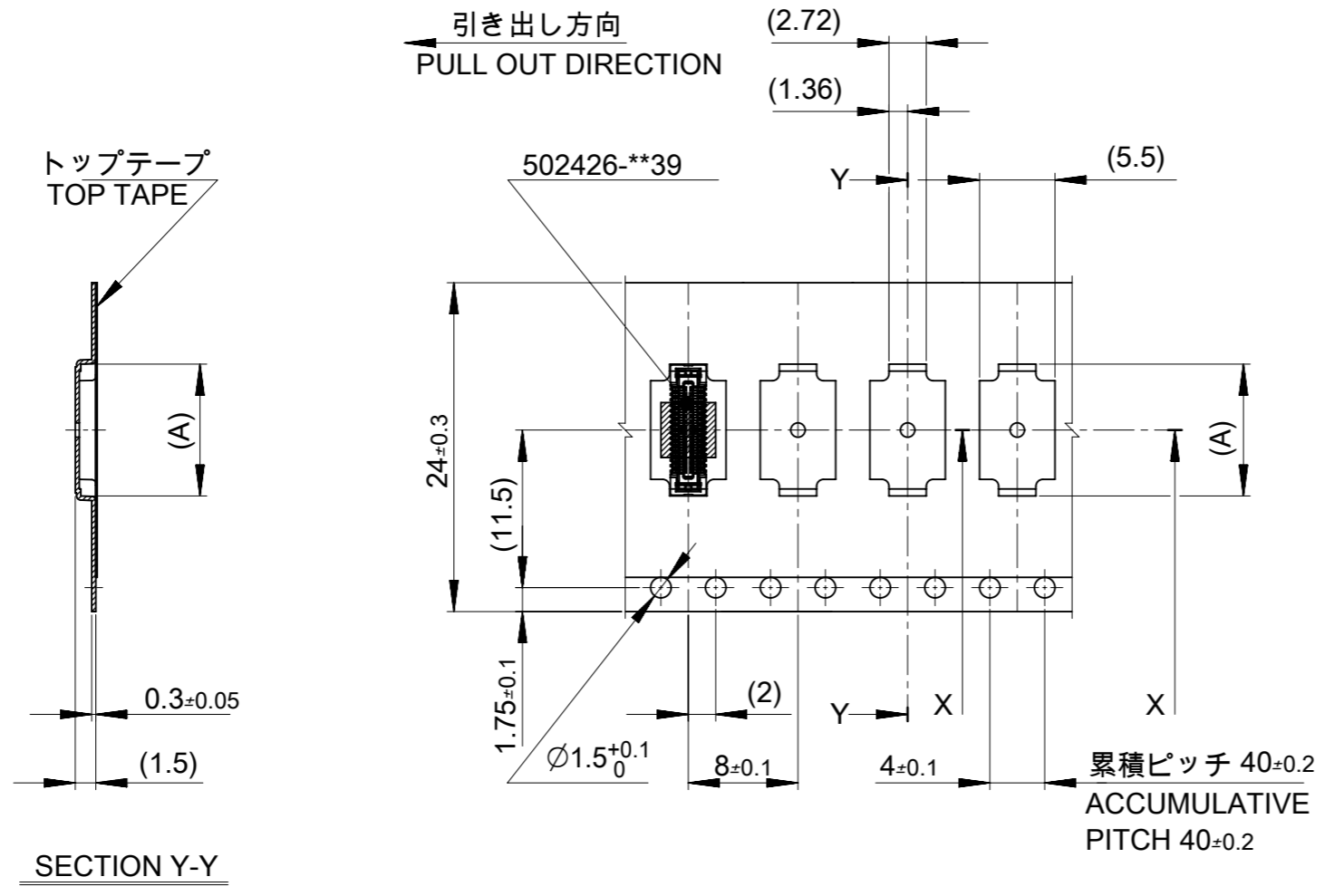

24mm 幅キャリアテープ  
24mm WIDTH CARRIER TAPE

24	29.4	25.4	15.22	502426-6030	60
			13.22	502426-5030	50
			11.22	502426-4030	40
			9.62	502426-3230	32
			9.22	502426-3030	30
キャリアテープ幅 CARRIER TAPE WIDTH	C	B	(A)	MATERIAL No.	CKT.
MODEL No.			502426-**30		

THIS DRAWING CONTAINS INFORMATION THAT IS PROPRIETARY TO MOLEX ELECTRONIC TECHNOLOGIES, LLC AND SHOULD NOT BE USED WITHOUT WRITTEN PERMISSION

DIMENSION UNITS mm	SCALE NTS	CURRENT REV DESC: REVISED		<b>molex</b>		
GENERAL TOLERANCES (UNLESS SPECIFIED)		EC NO: 641594				
ANGULAR TOL	± °	DRWN: TNAKAGAWA01 2020/07/16		PRODUCT CUSTOMER DRAWING		
4 PLACES	±	CHK'D: HSHIMUYAMA 2020/10/16		DOCUMENT NUMBER		
3 PLACES	±	APPR: SHOSHIKAWA 2020/10/17		SD-502426-004		
2 PLACES	±	INITIAL REVISION:		DOC TYPE	DOC PART	REVISION
1 PLACE	±	DRWN: RTAKEUCHI 2007/12/26		PSD	001	F
0 PLACES	±	APPR: MSASAO 2007/12/27		SHEET NUMBER		
DRAFT WHERE APPLICABLE MUST REMAIN WITHIN DIMENSIONS	THIRD ANGLE PROJECTION	DRAWING	SERIES	MATERIAL NUMBER	CUSTOMER	
		A3-SIZE	502426	SEE TABLE	GENERAL	3 OF 4

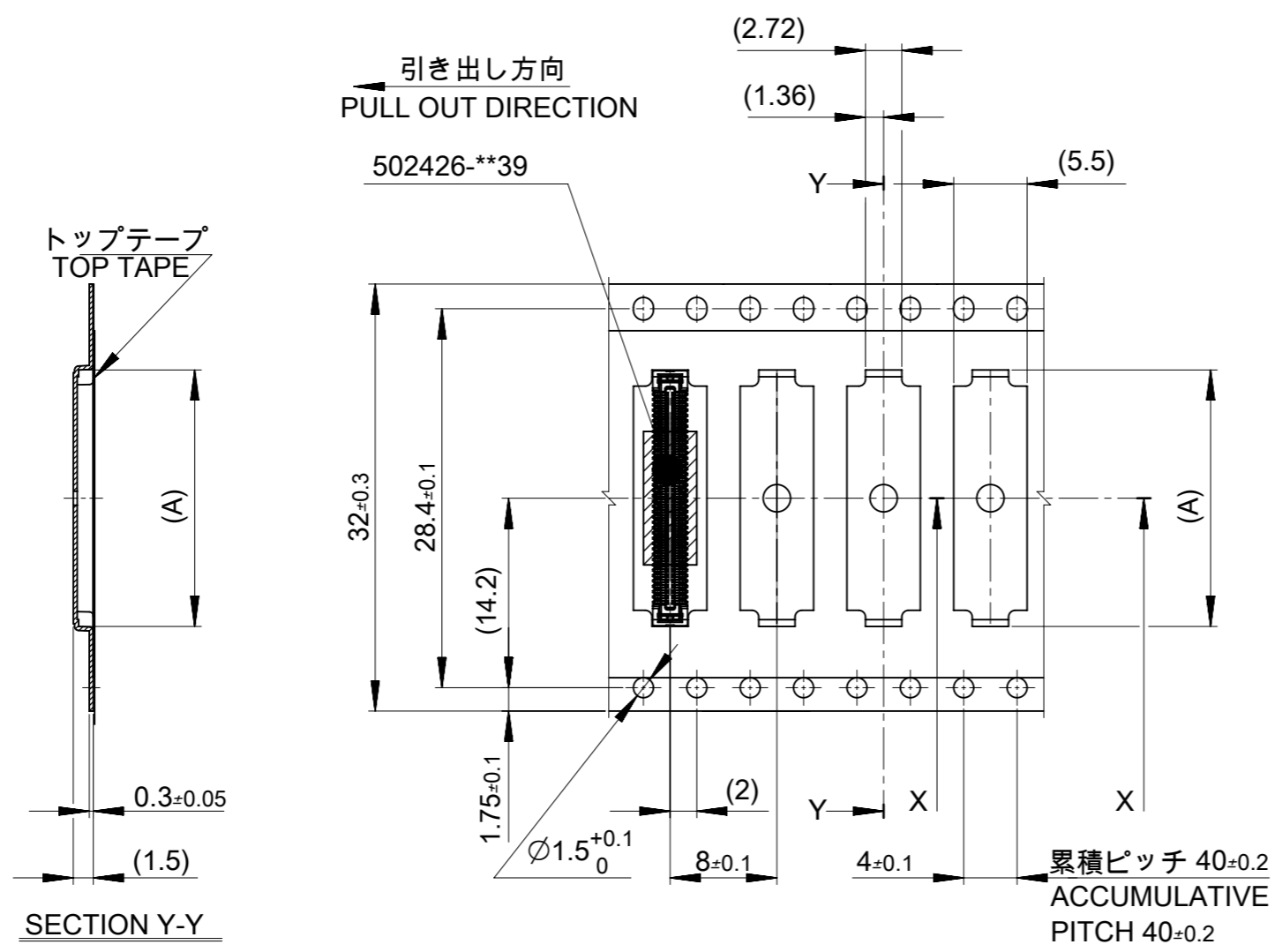

32mm 幅キャリアテープ  
32mm WIDTH CARRIER TAPE

32	37.4	33.4	21.22	502426-9030	90
			19.22	502426-8030	80
			17.22	502426-7030	70
キャリアテープ幅 CARRIER TAPE WIDTH	C	B	(A)	MATERIAL No.	CKT.
MODEL No.				502426-**30	

THIS DRAWING CONTAINS INFORMATION THAT IS PROPRIETARY TO MOLEX ELECTRONIC TECHNOLOGIES, LLC AND SHOULD NOT BE USED WITHOUT WRITTEN PERMISSION

DIMENSION UNITS mm	SCALE NTS	CURRENT REV DESC: REVISED		<b>molex</b>		
GENERAL TOLERANCES (UNLESS SPECIFIED)		EC NO: 641594				
ANGULAR TOL	± °	DRWN: TNAKAGAWA01 2020/07/16		PRODUCT CUSTOMER DRAWING		
4 PLACES	±	CHK'D: HSHIMYOYAMA 2020/10/16		DOCUMENT NUMBER		
3 PLACES	±	APPR: SHOSHIKAWA 2020/10/17		SD-502426-004		
2 PLACES	±	INITIAL REVISION:		DOC TYPE	DOC PART	REVISION
1 PLACE	±	DRWN: RTAKEUCHI 2007/12/26		PSD	001	F
0 PLACES	±	APPR: MSASAO 2007/12/27		SHEET NUMBER		
DRAFT WHERE APPLICABLE MUST REMAIN WITHIN DIMENSIONS		THIRD ANGLE PROJECTION	DRAWING	SERIES	MATERIAL NUMBER	CUSTOMER
			A3-SIZE	502426	SEE TABLE	GENERAL