

2400
2500



e-chain system® E2/000 Series 2400/2500



Price Index



Series 2400/2500

Special Features / Options



IPA Qualification Certificate, Air Cleanliness Class ISO Class 3 (at v = 2 m/s) upon request



ESD classification: Electrically conductive ESD/ATEX version upon request



UL94 V2 classifications upon request

Assembly Tips



Snap-open mechanism, choice of snap-open on left or right. Hinged crossbar can be swiveled by more than 180° on both sides. Lightning-fast closing by hand. Secure fit without additional locking devices.

Other Installation Methods

Vertical, hanging ≤ 131.24 ft (40 m)

Vertical, standing ≤ 9.84 ft (3 m)

Side-mounted, un_supp. ≤ 3.28 ft (1 m)

Rotary requires further calculation

Usage Guidelines



- If snap-open accessibility along the inner or outer radius is required
- If integrated strain relief at the mounting point is required
- If modular interior separation is needed
- If long service life is required
- If easy installation is required



- If the application is very simple
➤ Series E200 E-Z Chain
- If greater stability is required
➤ Series E4-21 E4-1 Series

Features & Benefits

- 1 Tried-and-tested mounting bracket
- 2 Snap-open crossbar for easy opening from the left or right
- 3 Series 2500 snap-open on both sides along outer radius
- 4 Series 2400 snap-open on both sides along inner radius
- 5 Integrated strain relief possible
- 6 Modular interior separation
- 7 Easy assembly by optimized pin
- 8 Double stop dog for long unsupported length
- 9 Crossbars with high retention force
- 10 Also available as ESD version
- 11 Strain relief separator available

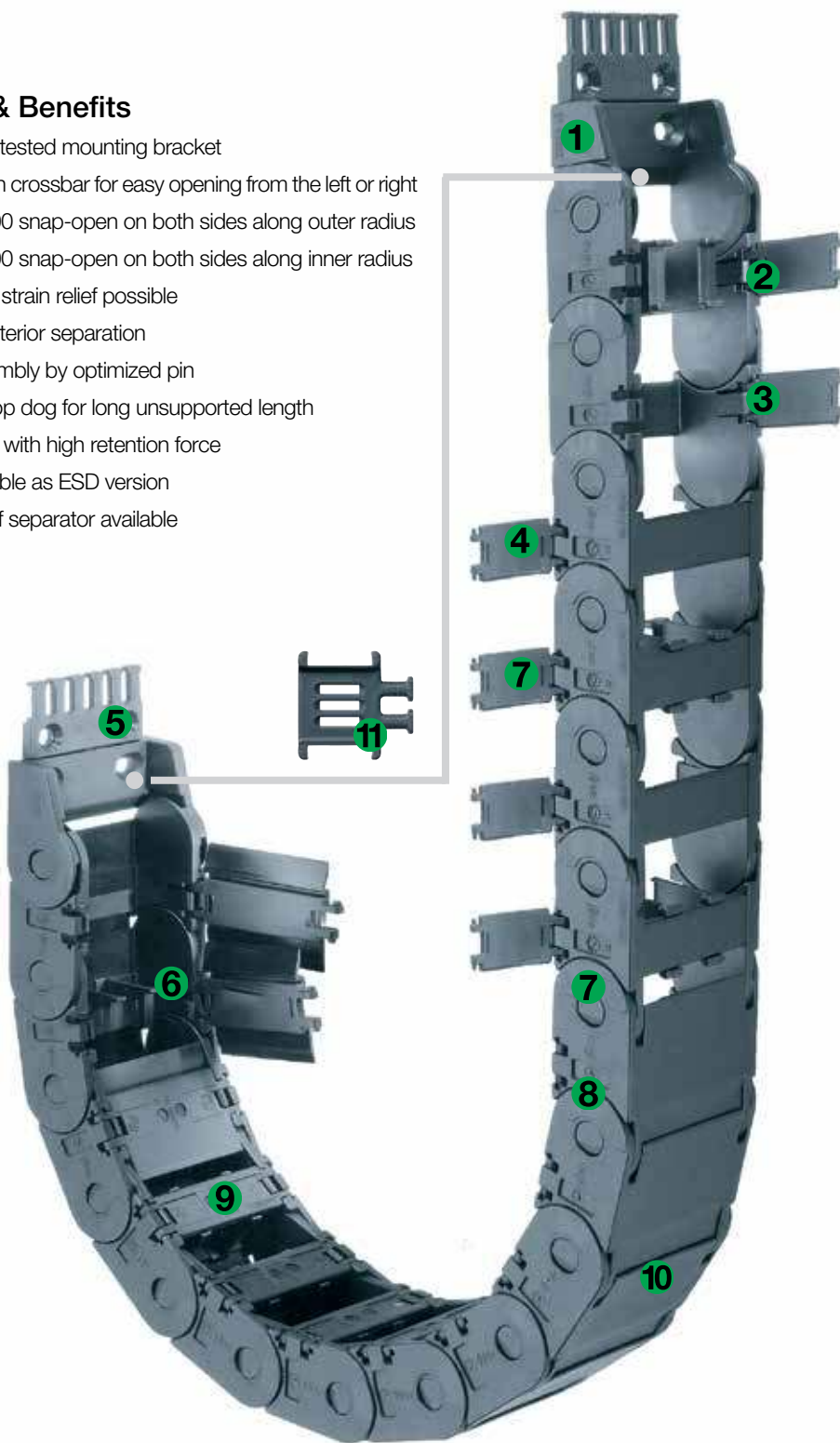

Order Example: Complete e-chain®

Please indicate chain length or number of links. Example:

9.84 ft (3 m) 2500-10-100-0



e-chain®

With 2 separators 25.1 assembled every 2nd link



Interior Separation

1 Set 2100-34PZB



Mounting Bracket

e-chain system® E2/000

Series 2400/2500

Installation Dimensions

Short travel, unsupported length

- FL_B = unsupported with permitted sag
 - FL_G = unsupported with straight upper run
- Further information ► Design, Chapter 1

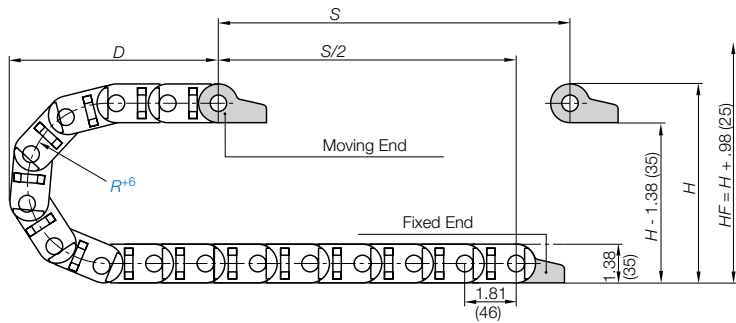
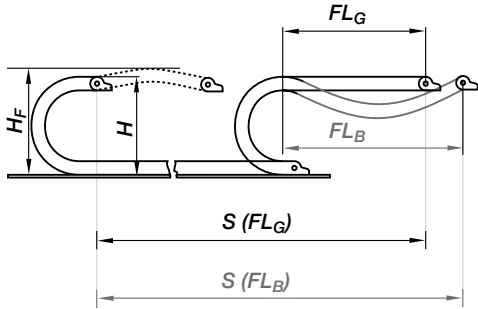

The required clearance height: $H_f = H + .98$ in. (25 mm) (with 1.01 lbs/ft (1.5 kg/m) fill weight). Please consult igus® if space is particularly restricted.

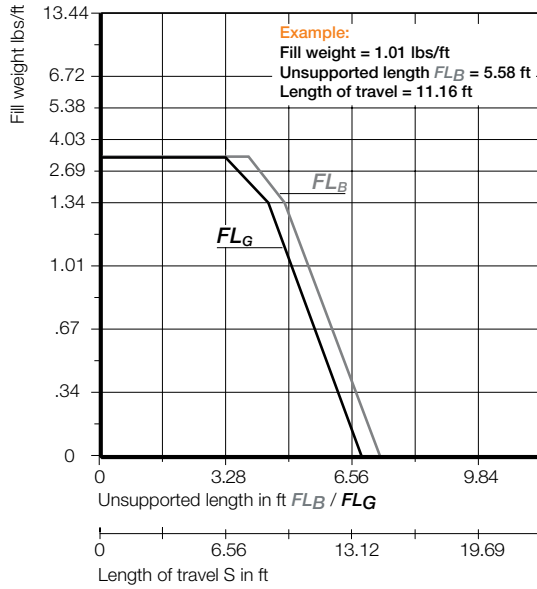

2400
2500

Short Travels - Unsupported



Unsupported e-chains® feature positive camber over short travels. This must be accounted for when specifying the clearance height. Please refer to **Installation dimensions** for further details.

Legend

- S = Length of travel
- R = Bending radius
- H = Nominal clearance height
- D = Overlength e-chain® radius in final position
- $K = \pi \cdot R + \text{safety buffer}$
- H_f = Required clearance height
- H_{RI} = Trough inner height
- H_2 = *Mounting height
- D_2 = Overlength - long travels, gliding
- K_2 = *Add-on

Pitch per link: = 1.81" (46 mm)
Links per ft (m): = 6.71 (22)
For center mount applications:
Chain length = $S/2 + K$

*If the mounting bracket location is set lower

R	2.16 (055**)	2.95 (075)	3.94 (100)	4.92 (125)	5.91 (150)	6.89 (175)	7.87 (200)	8.86 (225)	9.84 (250)
H	5.71 (145)	7.28 (185)	9.25 (235)	11.22 (285)	13.19 (335)	15.16 (385)	17.13 (435)	19.09 (485)	21.06 (535)
D	5.59 (142)	6.38 (162)	7.36 (187)	8.35 (212)	9.33 (237)	10.31 (262)	11.30 (287)	12.28 (312)	13.27 (337)
K	10.43 (265)	12.99 (330)	16.14 (410)	19.09 (485)	22.24 (565)	25.39 (645)	28.54 (725)	31.50 (800)	34.65 (880)

**upon request

For long travels with lowered mounting height

Long travel lengths from 32.8 ft. (10 m) to max. 328 ft. (100 m)

Note: For using Series 2400 for long travels (gliding), please consult with igus® first.

For long travels, igus® specifies Series 2500 that snap open on the outer radius.

For center mount applications:

Chain length: = $S/2 + K_2$

Long Travels - Gliding



If the unsupported length is exceeded, the e-chain®/ Tube must glide on itself. This requires a guide trough.

Design, Chapter 1

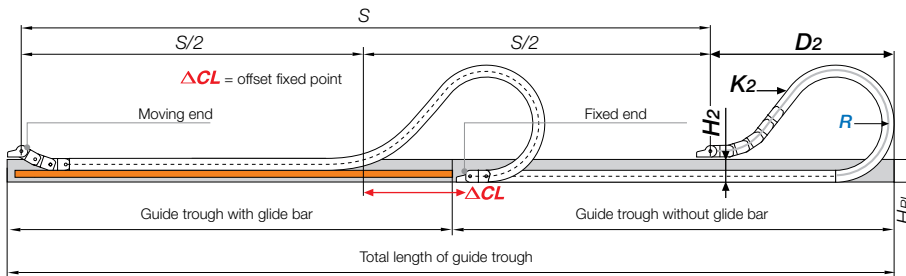

R	2.16 (055)	2.95 (075)	3.94 (100)	4.92 (125)	5.91 (150)	6.89 (175)	7.87 (200)	8.86 (225)	9.84 (250)
H_2	4.33 (110)	5.91 (150)	3.94 (100)	3.94 (100)	3.94 (100)	3.94 (100)	3.94 (100)	3.94 (100)	3.94 (100)
D_2^{25}	5.59 (142)	6.38 (162)	14.96 (380)	17.32 (440)	23.23 (590)	29.72 (755)	37.40 (950)	40.94 (1040)	44.49 (1130)
K_2	10.43 (265)	12.99 (330)	25.35 (644)	28.98 (736)	39.84 (1012)	48.90 (1242)	57.95 (1472)	63.39 (1610)	70.63 (1794)
ΔCL	—	—	8.03 (204)	9.61 (244)	14.33 (364)	19.84 (504)	26.54 (674)	29.69 (754)	31.65 (804)

Speed / acceleration FL_G	max. 65.6 ft/s (20 m/s) / max. 656 ft/s ² (200 m/s ²)
Speed / acceleration FL_B	max. 9.84 ft/s (3 m/s) / max. 19.69 ft/s ² (6 m/s ²)
Gliding speed / acceleration (maximum)	max. 32.8 ft/s (10 m/s) / max. 164 ft/s ² (50 m/s ²)
Material - permitted temperature	igumid G / -40°F (-40°C) up to +248°F (+120°C)
Flammability Class, igumid G	VDE 0304 IIC UL94 HB

Technical Data



Details of material properties

► Chapter 1



PDF: igus.com/e-chain-pdfs
Product information: igus.com/e-chains



Series 2400 - snap-open along the inner radius

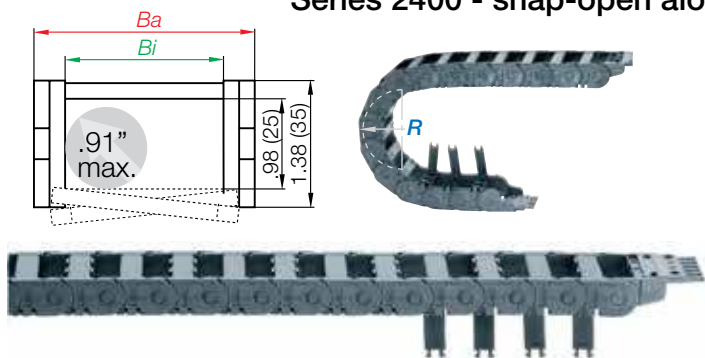

Part Number Structure

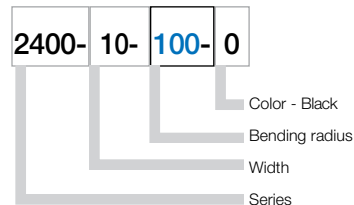

Series 2500 - snap-open along the outer radius

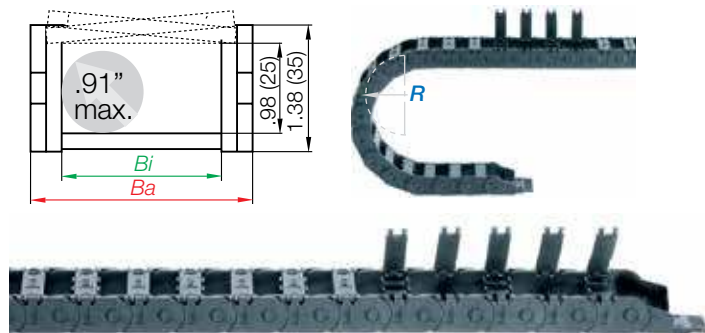

Part Number Structure

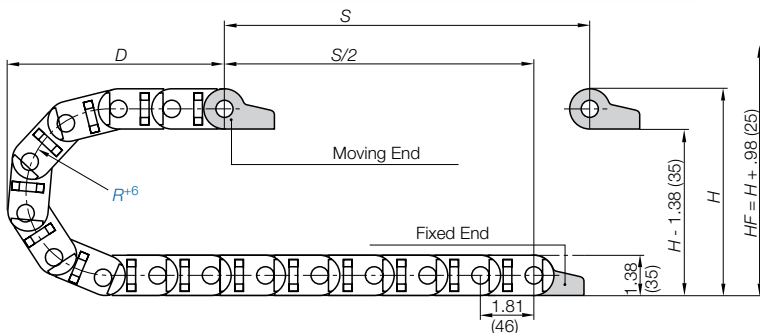
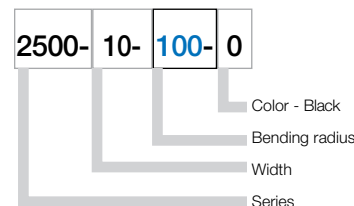

Supplement part number with required radius. Example: 2400-10--0
Pitch: 1.81 in. (46 mm) per link links/ft(m) = 6.71 (22)

Part Number.

2400-02- <input type="text"/> -0	2500-02- <input type="text"/> -0	Bi in. (mm)	Ba in. (mm)	Weight lbs/ft (kg/m)
2400-02- <input type="text"/> -0	2500-02- <input type="text"/> -0	.98 (25)	1.61 (41)	≈ 0.52 (0.77)
2400-03- <input type="text"/> -0	2500-03- <input type="text"/> -0	1.50 (38)	2.13 (54)	≈ 0.56 (0.83)
2400-05- <input type="text"/> -0	2500-05- <input type="text"/> -0	2.24 (57)	2.87 (73)	≈ 0.61 (0.91)
2400-07- <input type="text"/> -0	2500-07- <input type="text"/> -0	3.03 (77)	3.66 (93)	≈ 0.68 (1.01)
2400-09- <input type="text"/> -0	2500-09- <input type="text"/> -0	3.50 (89)	4.13 (105)	≈ 0.73 (1.08)
2400-10- <input type="text"/> -0	2500-10- <input type="text"/> -0	4.06 (103)	4.69 (119)	≈ 0.77 (1.15)
2400-12- <input type="text"/> -0	2500-12- <input type="text"/> -0	4.92 (125)	5.55 (141)	≈ 0.82 (1.22)

Choose from the radii below for all of the above sizes
Radius (mm) Example: 2400-10--0

	055	075	100	125	150	175	200	225	250
R	2.16 (055)	2.95 (075)	3.94 (100)	4.92 (125)	5.91 (150)	6.89 (175)	7.87 (200)	8.86 (225)	9.84 (250)
H	5.71 (145)	7.28 (185)	9.25 (235)	11.22 (285)	13.19 (335)	15.16 (385)	17.13 (435)	19.09 (485)	21.06 (535)
D	5.59 (142)	6.38 (162)	7.36 (187)	8.35 (212)	9.33 (237)	10.31 (262)	11.30 (287)	12.28 (312)	13.27 (337)
K	10.43 (265)	12.99 (330)	16.14 (410)	19.09 (485)	22.24 (565)	25.39 (645)	28.54 (725)	31.50 (800)	34.65 (880)

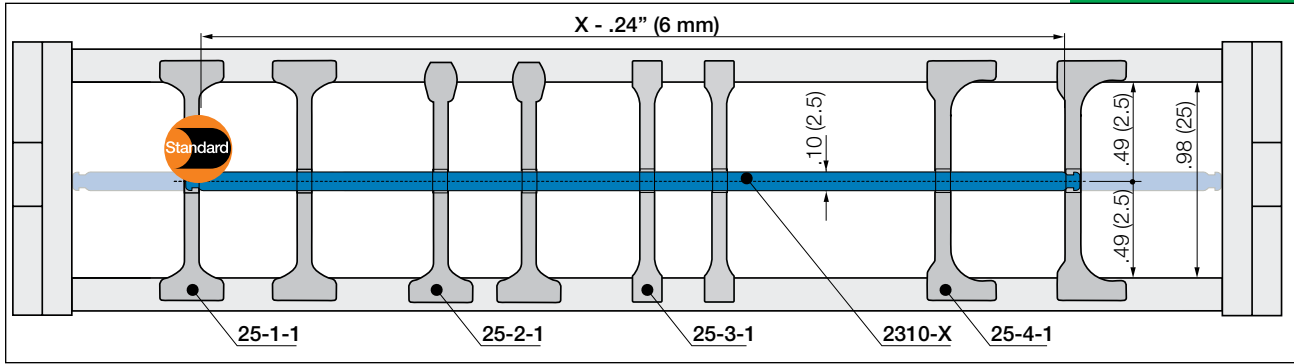

In the standard configuration separators are assembled every 2nd e-chain® link



Separator, wide base

Unassembled	Part No. 25.1
Assembled	Part No. 25.1.1

- **Standard separator 25.1 for all applications**

Separator with wide base for maximum locking strength and safe standing in e-chains®.



Separator, narrow head

Unassembled	Part No. 25.2
Assembled	Part No. 25.2.1

- **Separator 25.2**

For even faster installation
is used when vertical and horizontal separation is required. Due to its slot, it allows basic vertical/horizontal shelving arrangements.



Separator, narrow base

Unassembled	Part No. 25.3
Assembled	Part No. 25.3.1

- **Separator 25.3**

For many thin cables
is used when vertical and horizontal separation is required. Due to its slot, it allows basic vertical/horizontal shelving arrangements.



Separator, asymmetrical

Unassembled	Part No. 25.4
Assembled	Part No. 25.4.1

- **Separator 25.4**

For side mounted applications
is used when vertical and horizontal separation is required. Due to its slot, it allows basic vertical/horizontal shelving arrangements.

Lockable full-width shelves - for the standard interior separation

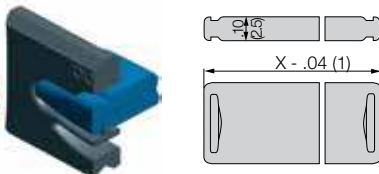

Full width shelf, lockable

Unassembled	Part No. 2300-X
Assembled	Part No. 2310-X

- **Full width shelf, lockable**

is used when vertical and horizontal separation is required. .

Width X in. (mm)	Part No. Unassembled	Part No. Assembled	Width X in. (mm)	Part No. Unassembled	Part No. Assembled	Width X in. (mm)	Part No. Unassembled	Part No. Assembled
0.59 (015)	2300-15	2310-15	2.36 (060)	2300-60	2310-60	3.43 (087)	2300-87	2310-87
0.98 (025)	2300-25	2310-25	2.44 (062)	2300-62	2310-62	3.54 (090)	2300-90	2310-90
1.18 (030)	2300-30	2310-30	2.56 (065)	2300-65	2310-65	3.94 (100)	2300-100	2310-100
1.50 (038)	2300-38	2310-38	2.76 (070)	2300-70	2310-70	4.06 (103)	2300-103	2310-103
1.57 (040)	2300-40	2310-40	2.95 (075)	2300-75	2310-75	4.33 (110)	2300-110	2310-110
1.97 (050)	2300-50	2310-50	3.03 (077)	2300-77	2310-77	4.72 (120)	2300-120	2310-120
2.24 (057)	2300-57	2310-57	3.15 (080)	2300-80	2310-80	4.92 (125)	2300-125	2310-125



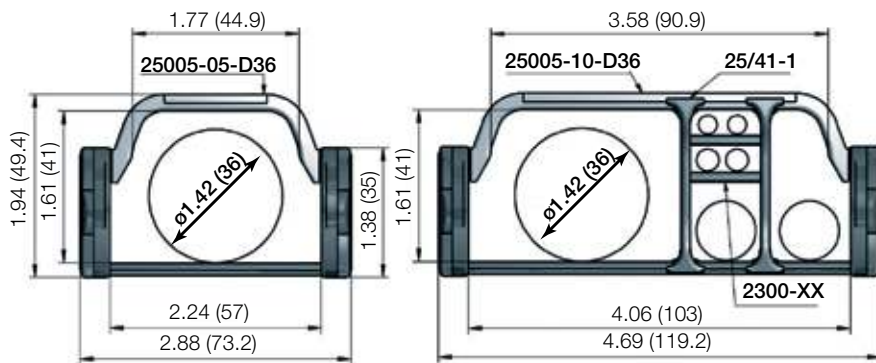

Part Number.

Extender crossbars
for e-chains®
that snap-open
along inner radius

Extender crossbars
for e-chains®
that snap-open
along outer radius

Bi

Ba

in. (mm)

in. (mm)

2400-05D36- -0

2500-05D36- -0

2.24 (57)

2.87 (73)

2400-10D36- -0

2500-10D36- -0

4.06 (103)

4.69 (119)

Choose from the radii below for all of the above sizes

Radius (mm)

Example: 2400-10D36- -0

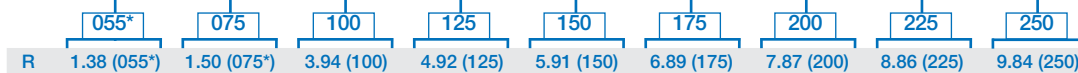

*Radius 055 only possible with Series 2500 e-chains®

Interior separation for extender crossbars

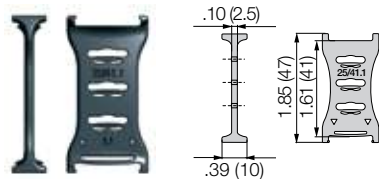

Separator, wide base

Unassembled **Part No. 25/41.1**

Assembled **Part No. 25/41.1.1**

- **Standard separator 25/41-1, wide base**

For maximum locking strength and base standing. In standard configuration separators are assembled every 2nd e-chain® link.

Lockable full-width shelves - for the standard interior separation

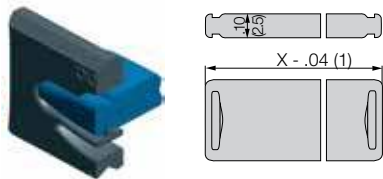

Full width shelf, lockable

Unassembled **Part No. 2300-X**

Assembled **Part No. 2310-X**

- **Full width shelf, lockable**

is used when vertical and horizontal separation is required. Due to its slot, it allows basic vertical/horizontal shelving arrangements.

Width X	Part No.	Part No.	Width X	Part No.	Part No.	Width X	Part No.	Part No.
in. (mm)	Unassembled	Assembled	in. (mm)	Unassembled	Assembled	in. (mm)	Unassembled	Assembled
0.59 (015)	2300-15	2310-15	2.36 (060)	2300-60	2310-60	3.43 (087)	2300-87	2310-87
0.98 (025)	2300-25	2310-25	2.44 (062)	2300-62	2310-62	3.54 (090)	2300-90	2310-90
1.18 (030)	2300-30	2310-30	2.56 (065)	2300-65	2310-65	3.94 (100)	2300-100	2310-100
1.50 (038)	2300-38	2310-38	2.76 (070)	2300-70	2310-70	4.06 (103)	2300-103	2310-103
1.57 (040)	2300-40	2310-40	2.95 (075)	2300-75	2310-75	4.33 (110)	2300-110	2310-110
1.97 (050)	2300-50	2310-50	3.03 (077)	2300-77	2310-77	4.72 (120)	2300-120	2310-120
2.24 (057)	2300-57	2310-57	3.15 (080)	2300-80	2310-80	4.92 (125)	2300-125	2310-125

Separator with integrated strain relief

Strain relief separator Part No. 2020-Z can be integrated into the mounting bracket and can be placed there at any point of the e-chain®. It combines strain relief and interior separation, it can be installed on the first or last e-chain® link and is easy to assemble without any screws.

For more information ► Chapter 10, Strain Relief



e-chain system® E2/000

Series 2400/2500

Mounting Bracket - Plastic



2400
2500

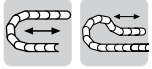

Option 1: pivoting

- For unsupported and gliding applications
- Well suited for tight installation conditions
- Detachable strain relief tiwrap plates
- Can be mounted on the fixed and/or moving end

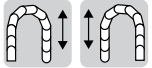
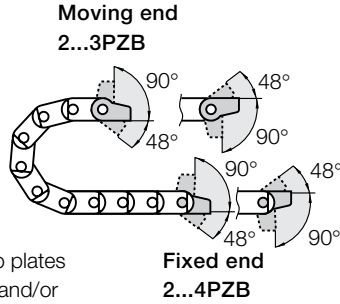

Option 2: locking

- For unsupported and gliding applications
- Extreme speed and/or accelerations
- For height restricted applications
- Can be mounted on the fixed and/or moving end

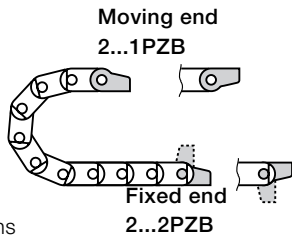

Part Number Structure



- With 10 cable tiwraps
- With tiwrap plates
- Complete Set
34 = Pivoting
12 = Locking
- Mounting brackets for selected chain type

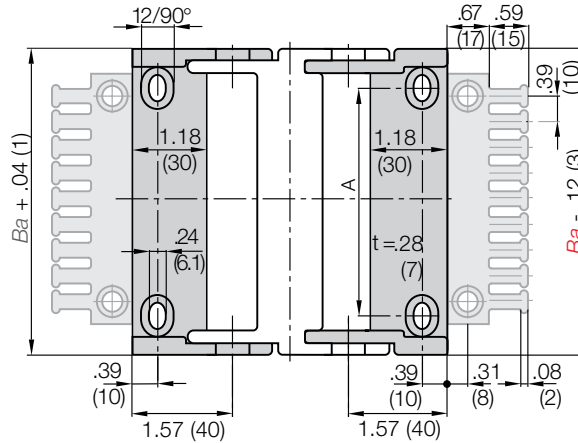

Full set, for both ends:

2020- 34 PZB Full set, each part with pin/bore + tiwrap plate

Single-part order:

- 2020- 3 PZB Mounting bracket with bore + tiwrap plate
- 2020- 4 PZB Mounting bracket with pin + tiwrap plate

Part No. Full Set (pivoting)

With Tiwrap Plates
Series 2400/2500:
2020-34PZB

Part No. Full Set (locking)

With Tiwrap Plates
+ 10 cable ties
Series 2400/2500:
2020-34PZBK1

For Chain Type	Part No. Full set without Tiwrap Plate	Part No. Full Set with Tiwrap Plate	Part No. Full Set with Tiwrap Plate + 10 cable ties	Dimension A in. (mm)	Number of teeth
2400/2500-02	2020- <input type="checkbox"/> PZ	2020- <input type="checkbox"/> PZB	2020- <input type="checkbox"/> PZBK1	.47 (12)	3
2400/2500-03	2030- <input type="checkbox"/> PZ	2030- <input type="checkbox"/> PZB	2030- <input type="checkbox"/> PZBK1	.98 (25)	4
2400/2500-05	2050- <input type="checkbox"/> PZ	2050- <input type="checkbox"/> PZB	2050- <input type="checkbox"/> PZBK1	1.73 (44)	6
2400/2500-07	2070- <input type="checkbox"/> PZ	2070- <input type="checkbox"/> PZB	2070- <input type="checkbox"/> PZBK1	2.52 (64)	8
2400/2500-09	2090- <input type="checkbox"/> PZ	2090- <input type="checkbox"/> PZB	2090- <input type="checkbox"/> PZBK1	3.03 (77)	9
2400/2500-10	2100- <input type="checkbox"/> PZ	2100- <input type="checkbox"/> PZB	2100- <input type="checkbox"/> PZBK1	3.54 (90)	10
2400/2500-12	2125- <input type="checkbox"/> PZ	2125- <input type="checkbox"/> PZB	2125- <input type="checkbox"/> PZBK1	4.41 (112)	12

34 or 12

For pivoting brackets choose 34
For locking brackets choose 12
Example: 2020- 34 PZB

PDF: igus.com/e-chain-pdfs
Product information: igus.com/e-chains



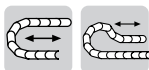

Option 1: pivoting

- For unsupported applications
- Bolted connection outside of chain cross section
- Confined installation conditions
- Attachment points on all sides
- Stackable

Moving end
24001...1

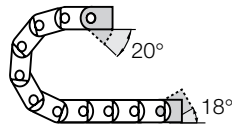

Fixed end
24001...2

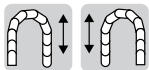
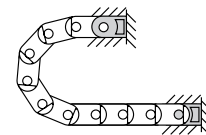

Option 2: locking

- For vertical hanging/standing applications
- Bolted connection outside of chain cross section
- For very high speeds and accelerations
- Attachment points on all sides
- Stackable

Moving end
24101...1

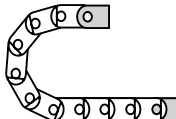

Fixed end
24101...2

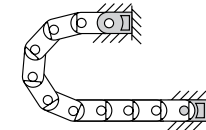

Part Number Structure

24001-02-12ZB

- With tiwrap plates
- Complete Set
- Width
- Mounting brackets for selected chain type
24001 = Pivoting
24101 = Locking

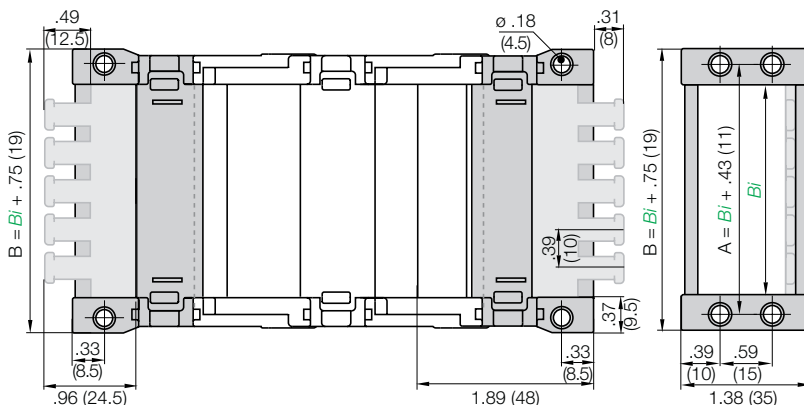

Full set, for both ends:

24001-12ZB Full set, each part with pin/bore + tiwrap plate

Single-part order:

24001-1ZB Mounting bracket with bore + tiwrap plate

24001-2ZB Mounting bracket with pin + tiwrap plate

Part No. Full Set (pivoting)

With Tiwrap Plates

Series 2480:

24001-Width-12ZB

Part No. Full Set (pivoting)

Without Tiwrap Plates

Series 2480:

24001-Width-12

For Chain Type	Part No. Full set with Tiwrap Plate	Part No. Full Set without Tiwrap Plate	Dimension A in. (mm)	Number of Teeth
2400/2500-02	24001-02-12ZB	24001-02-12	1.42 (36)	2
2400/2500-03	24001-03-12ZB	24001-03-12	1.93 (49)	4
2400/2500-05	24001-05-12ZB	24001-05-12	2.68 (68)	6
2400/2500-07	24001-07-12ZB	24001-07-12	3.46 (88)	7
2400/2500-09	24001-09-12ZB	24001-09-12	3.94 (100)	9
2400/2500-10	24001-10-12ZB	24001-10-12	4.49 (114)	10
2400/2500-12	24001-12-12ZB	24001-12-12	5.35 (136)	12

24001 or 24101

For pivoting brackets choose 24001

For locking brackets choose 24101

Example: 24001-02-12ZB

e-chain system® E2/000
 Series 2400/2500
 Mounting Bracket - Steel



2400
 2500

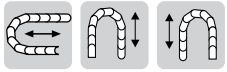

Option 1: Steel

- Pivoting connections
- One part (two-piece) for all chain widths
- Electrically conductive
- Bolted connection outside of chain cross-section possible

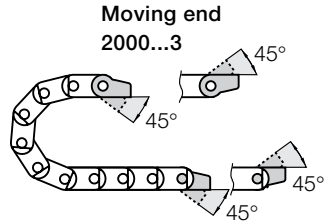

Fixed end
 2000...2

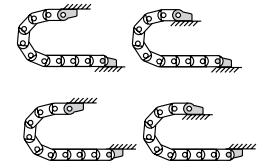
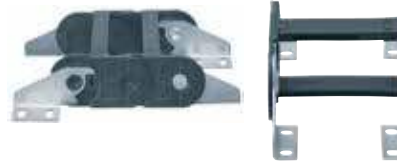

Possible installation configurations -

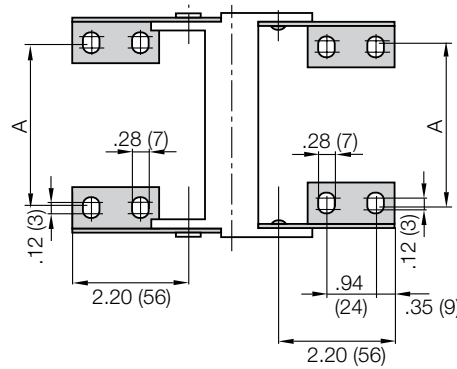
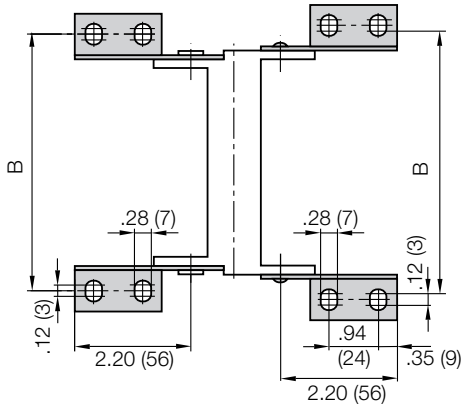

Chain Type	Part No. Full Set	Dimension A		Dimension B	
		in.	(mm)	in.	(mm)
2400/2500-02	2000-32	—	—	2.36	(60)
2400/2500-03	2000-32	.98	(25)	2.87	(73)
2400/2500-05	2000-32	1.73	(44)	3.62	(92)
2400/2500-07	2000-32	2.52	(64)	4.41	(112)
2400/2500-09	2000-32	2.99	(76)	4.88	(124)
2400/2500-10	2000-32	3.54	(90)	5.43	(138)
2400/2500-12	2000-32	4.41	(112)	6.30	(160)

Part No. Mounting Brackets Full Set
 4 parts, 2 with pin, 2 with bore
 Series 2400/2500:
2000-32

Part No. Mounting Bracket Moving End
 2 parts, 1 left & 1 right
 Series 2400/2500:
2000-3

Part No. Mounting Bracket Fixed End
 2 parts, 1 left & 1 right
 Series 2400/2500:
2000-2

PDF: igus.com/e-chain-pdfs
 Product information: igus.com/e-chains



Tiewrap Plates

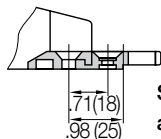

Shown assembled

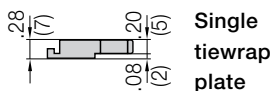

Single tiewrap plate

Option 1:

Tiewrap plates as an individual part

Available as an individual component, can be fixed onto a mounting bracket with the use of a profile rail.

Tiewrap Plates	n Number of Teeth	Dimension C	Dimension B
2020-ZB	3	1.18 (30)	.59 (15)
2030-ZB	4	1.57 (40)	.79 (20)
2040-ZB	5	1.97 (50)	1.18 (30)
2050-ZB	6	2.36 (60)	1.57 (40)
2070-ZB	8	3.15 (80)	2.36 (60)
2090-ZB	9	3.54 (90)	2.76 (70)
2100-ZB	10	3.94 (100)	3.15 (80)
2125-ZB	12	4.72 (120)	3.94 (100)

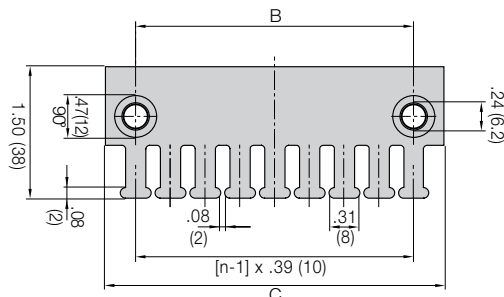

For more information please refer to strain relief section of Chapter 10



Cable tiewraps as individual parts

Cable tiewraps 100 pieces/bag	Width x Length		Maximum Ø		Tensile Strength	
	in.	(mm)	in.	(mm)	lbs	(N)
CFB-001	.19 x 5.91	(4.8 x 150)	1.42	(36)	50	(222)

Strain relief for steel mounting brackets

Clip-on connection is not possible with steel mounting brackets. In this case, the tiewrap plates must be bolted directly into separate bore holes in front of the mounting bracket. Alternatively the tiewrap plates **20XX-ZB** can be also used here. **Details chapter 10**

e-chain[®] E2/000

Series 2400/2500

Guide Trough



2400
2500

Guide troughs are used with applications where the upper run of the e-chain[®] glides on the lower run. If using igus[®] steel guide troughs, the following components are required:

- Full travel length of guide trough
Part Number 92-30
- 1/2 travel length of glide bars
Part Number 92-01
- Installation sets as end connectors
Part Number 92-50-XX

-XX indicates the length of the profile rail on which the guide trough is mounted. The values and part numbers are specified in the table on the left. The standard length of the trough components and glide bars is 6.56 ft (2 m.) The required overall length of the guide trough directly correlates to the length of travel.

Example:
Length of travel 164 ft (50 m)
Center mounted

Required guide troughs:
164 ft (50 m) guide trough
82 ft (25 m) glide bar
= 25 sections of 6.56 ft
(2 m) guide trough
Part No. 92-30
= 13 sections of 6.56 ft (2 m) glide bar
Part No. 92-01



Required number of installation sets:
= Number of guide trough components + 1
= 25 + 1 = 26
Part number of the installation sets

Example: 92-50-400 for 15.75" (400 mm) long profile rail.

Width of Crossbar
2500-05-200-0

	B_{Ri}	Installation Part No.
-02*	1.81 (46)	—
-03	2.32 (59)	92-50-175
-05	3.07 (78)	92-50-200
-07	3.86 (98)	92-50-225
-09	4.37 (111)	92-50-225
-10	4.88 (124)	92-50-250
-12	5.75 (146)	92-50-275

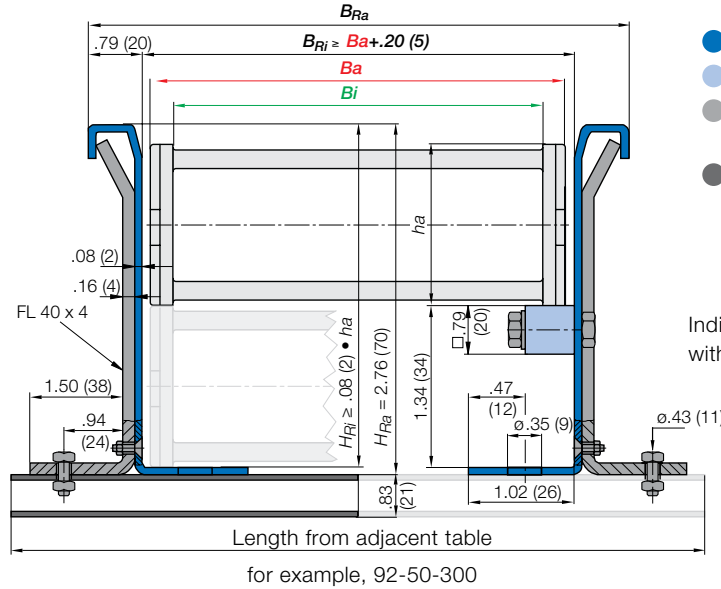

- Guide trough
- Glide bars
- Installation set "Basic"
- Profile rail

Individual attachment without profile rail

* Specialized guide trough available upon request

PDF: igus.com/e-chain-pdfs
Product information: igus.com/e-chains

