



Specification

SPECIFICATION

- Part No. : **AP.12B.07.0057A**
- Spec No. : **AP.12A.01**
- Product Name : 12mm Two Stage Active GPS Patch Antenna
- Features : Ultra Miniature GPS active patch
High performance
Ultra low power consumption
RoHS compliant
- Photo :





Specification

1.0 Introduction

This miniaturised GPS Active Antenna module combines a tiny 12mm squared ceramic patch antenna from Cirocomm with a two stage low noise amplifier. It is available as a 'plug and play' format for onboard integration with GPS receiver modules via ultra thin coaxial cable and connector from IPEX.

Only 5.5mm in height, this new Taoglas active antenna module utilises XtremeGain™ technology for the highest industry sensitivity.

Designed for use with the new generation of GPS receiver modules using chipsets from SiRF, Ublox, Nemerix, Fastrax, Navsync, Falcom, Telit, Tyco, Siemens etc.

2.0 Specification

Antenna

Frequency	1575.42 ± 1.023MHz
Antenna Gain	Typ 1.5 dBi @ Zenith(13.4mm*13.4mm Ground Plane)
Impedance	50 Ω
Polarization	RHCP
Axial Ratio	Max 4.0dB @ Zenith
Patch Dimension	12mm x 12mm x 3.5mm

LNA

Frequency	1575.42 ± 1.023MHz
Gain	Typ. 25dB @ 25°C ± 5°C
Noise Figure	Typ. 1.4dB @ 25°C ± 5°C Max 1.8dB @ 85°C

Cable* & Connector

RF Cable	Coaxial Cable ϕ 1.13 ± 0.1mm, length 57 ± 2.0mm
Connector	Ipex MHFI (U.FL)



Specification

Total Specification

Frequency	1575.42 ± 1.023MHz
Gain	23.5 ± 4dBic @ 90°
Output Impedance	50 Ω
Polarization	RHCP
Output VSWR	Max 2.0
Input Voltage	Min. 2.5V Max. 5.5V
Power Consumption	At 3.0V Typ. 13mA, Max. 15mA

3.0 Technical Drawing

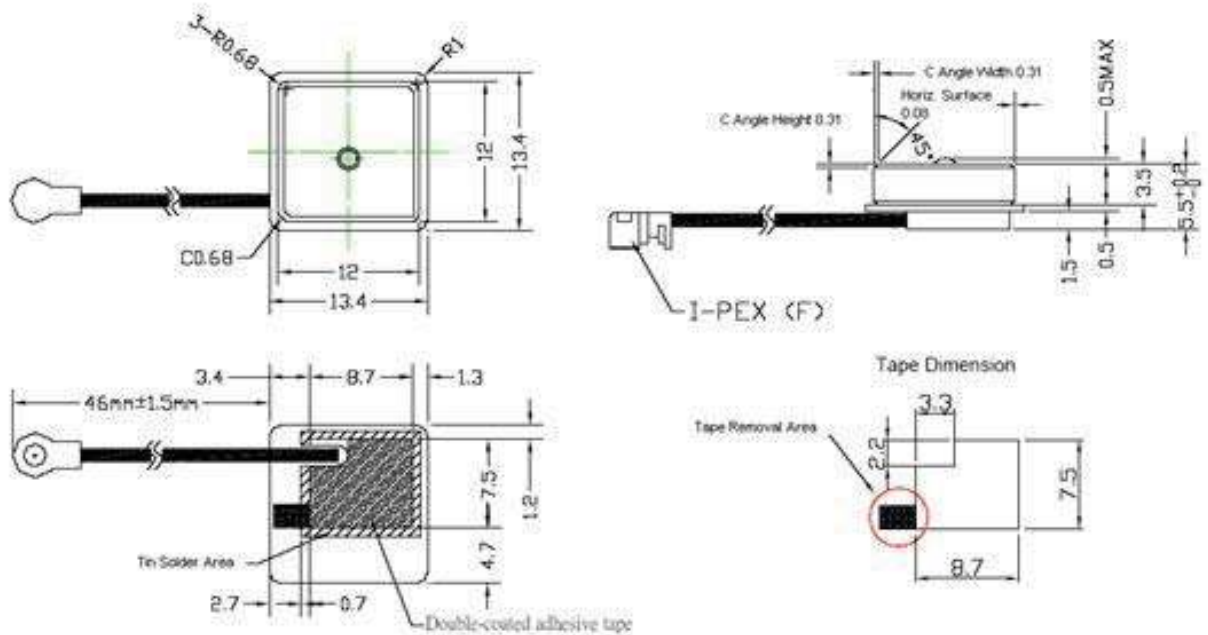

Unit : mm
Tolerance : ±0.1 mm