

2600
2700



e-chain system® E2/000 Series 2600/2700



Price Index



Series 2600/2700

Special Features / Options



IPA Qualification Certificate, Air Cleanliness Class ISO Class 3 (at v = 2 m/s) upon request



ESD classification: Electrically conductive ESD/ATEX version upon request



UL94 V2 classifications upon request

Assembly Tips



Snap-open mechanism, choice of snap-open on left or right. Hinged crossbar can be swiveled by more than 180° on both sides. Lightning-fast closing by hand. Secure fit without additional locking devices.

Other Installation Methods

Vertical, hanging ≤ 164 ft (50 m)

Vertical, standing ≤ 9.84 ft (3 m)

Side-mounted, un_supp. ≤ 3.28 ft (1 m)

Rotary requires further calculation

Usage Guidelines



- If snap-open accessibility along the inner or outer radius is required
- If integrated strain relief at the mounting point is required
- If modular interior separation is needed
- If long service life is required
- If easy installation is required



- If the application is very simple
➤ Series E26 E-Z Chain
- If greater stability is required
➤ Series E4-32 E4-1 Series

Features & Benefits

- 1 Tried-and-tested mounting bracket
- 2 Snap-open crossbar for easy opening from the left or right
- 3 Series 2600 snap-open on both sides along inner radius
- 4 Series 2700 snap-open on both sides along outer radius
- 5 Integrated strain relief possible
- 6 Modular interior separation
- 7 Easy assembly by optimized pin
- 8 Double stop dog for long unsupported length
- 9 Crossbars with high retention force
- 10 Also available as ESD version
- 11 Strain relief separator available

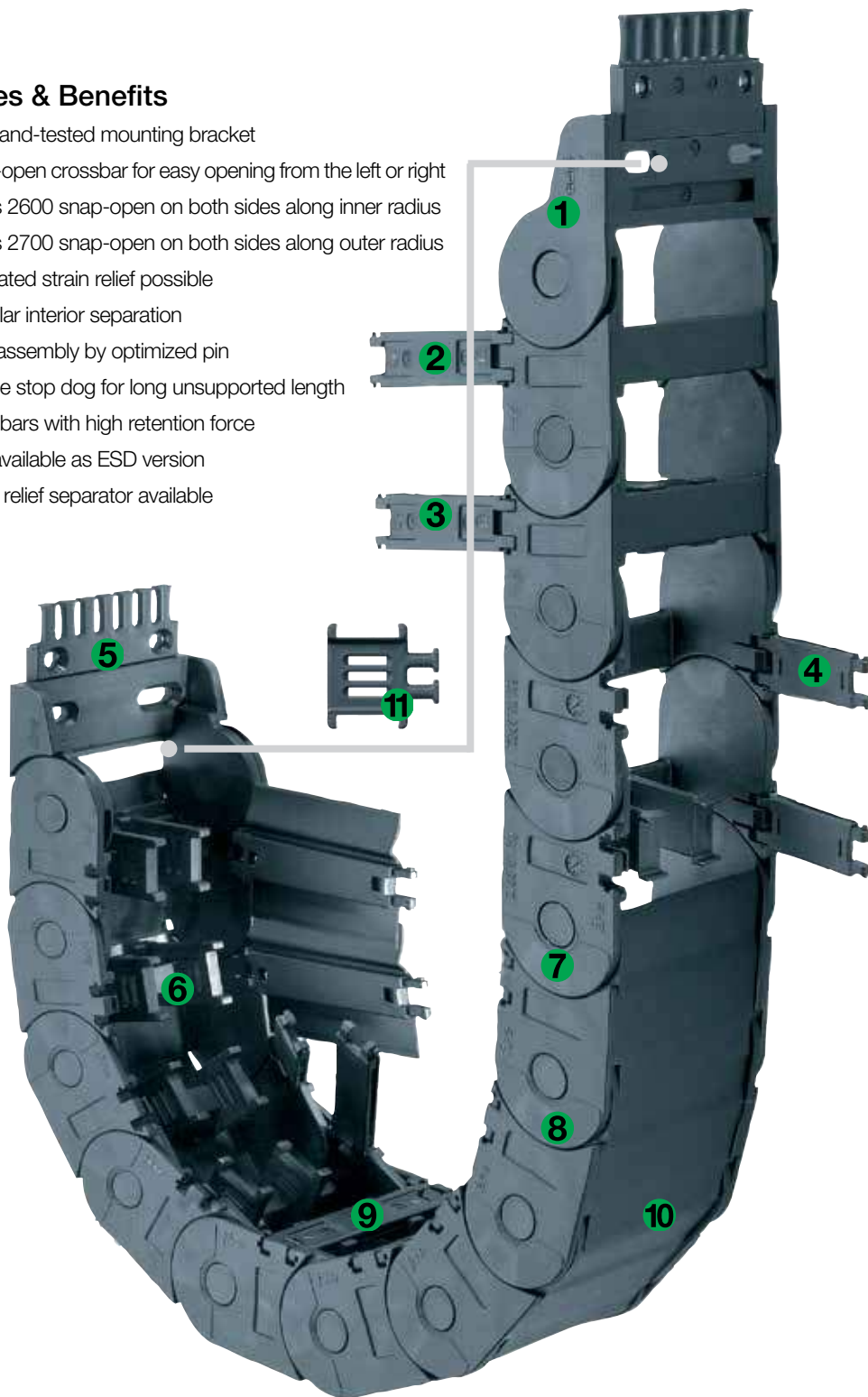

Order Example: Complete e-chain®

Please indicate chain length or number of links. Example:

9.84 ft (3 m) 2700-10-100-0



e-chain®

With 2 separators 35.1 assembled every 2nd link



Interior Separation

1 Set 2610-34PZB



Mounting Bracket

e-chain system® E2/000

Series 2600/2700

Installation Dimensions

Short travel, unsupported length

- FL_B = unsupported with permitted sag
 - FL_G = unsupported with straight upper run
- Further information ► Design, Chapter 1

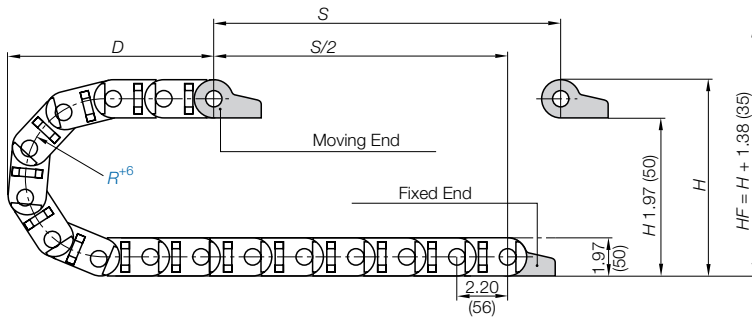
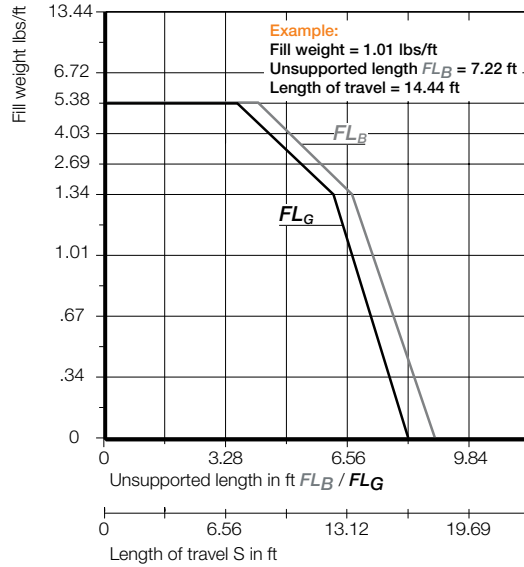
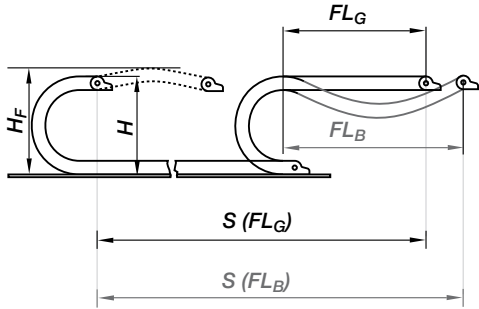

Pitch per link: = 2.20" (56 mm)
 Links per ft (m): = 5.49 (18)
 For center mount applications:
 Chain length = $S/2 + K$

The required clearance height: $H_F = H + 1.38$ in. (35 mm) (with 1.34 lbs/ft (2.0 kg/m) fill weight).
 Please consult igus® if space is particularly restricted.

R	2.48 (063)	2.95 (075)	3.94 (100)	4.92 (125)	5.91 (150)	6.89 (175)	7.87 (200)	9.84 (250)
H	6.93 (176)	7.87 (200)	9.84 (250)	11.81 (300)	13.78 (350)	15.75 (400)	17.72 (450)	21.65 (550)
D	6.77 (172)	7.24 (184)	8.23 (209)	9.21 (234)	10.20 (259)	11.18 (284)	12.17 (309)	14.13 (359)
K	12.20 (310)	13.78 (350)	16.93 (430)	19.88 (505)	23.03 (585)	26.18 (665)	29.33 (745)	35.43 (900)



2600
2700

Short Travels - Unsupported



Unsupported e-chains® feature positive camber over short travels. This must be accounted for when specifying the clearance height. Please refer to **Installation dimensions** for further details.



Legend

- S = Length of travel
- R = Bending radius
- H = Nominal clearance height
- D = Overlength e-chain® radius in final position
- $K = \pi \cdot R + \text{safety buffer}$
- H_F = Required clearance height
- H_{RI} = Trough inner height
- H₂ = *Mounting height
- D₂ = Overlength - long travels, gliding
- K₂ = *Add-on

*If the mounting bracket location is set lower

For long travels with lowered mounting height

Long travel lengths from 32.8 ft. (10 m) to max. 394 ft. (120 m)

For long travels, igus® specifies Series 2700 that snap open on the outer radius.

For center mount applications:

Chain length: = $S/2 + K_2$

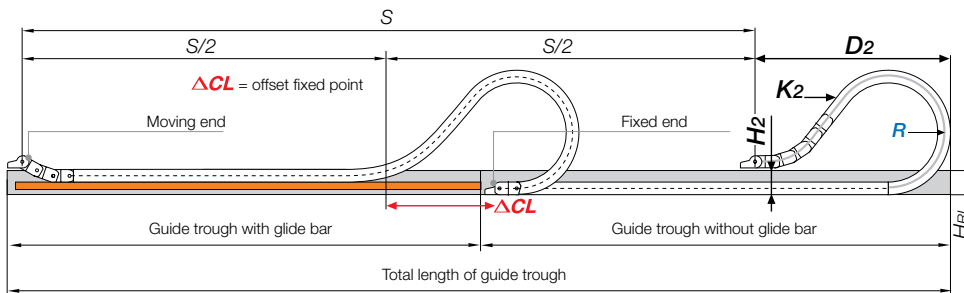

R	2.48 (063)	2.95 (075)	3.94 (100)	4.92 (125)	5.91 (150)	6.89 (175)	7.87 (200)	9.84 (250)
H ₂	5.12 (130)	5.91 (150)	6.54 (166)	6.54 (166)	6.54 (166)	6.54 (166)	6.54 (166)	6.54 (166)
D ₂ ²⁵	5.51 (140)	5.91 (150)	13.78 (350)	18.70 (475)	19.69 (500)	25.79 (655)	30.31 (770)	37.40 (950)
K ₂	13.19 (335)	14.76 (375)	24.25 (616)	30.87 (784)	35.28 (896)	44.09 (1120)	50.71 (1288)	63.94 (1624)
ΔCL	—	—	5.67 (144)	9.61 (244)	9.61 (244)	14.72 (374)	18.27 (464)	23.39 (594)

Long Travels - Gliding



If the unsupported length is exceeded, the e-chain® must glide on itself. This requires a guide trough. **Design, Chapter 1**

Speed / acceleration FL_G	max. 65.6 ft/s (20 m/s) / max. 656 ft/s ² (200 m/s ²)
Speed / acceleration FL_B	max. 9.84 ft/s (3 m/s) / max. 19.69 ft/s ² (6 m/s ²)
Gliding speed / acceleration (maximum)	max. 32.8 ft/s (10 m/s) / max. 164 ft/s ² (50 m/s ²)
Material - permitted temperature	igumid G / -40°F (-40°C) up to +248°F (+120° C)
Flammability Class, igumid G	VDE 0304 IIC UL94 HB

Technical Data



Details of material properties

► Chapter 1

PDF: igus.com/e-chain-pdfs
 Product information: igus.com/e-chains



Series 2600 - snap-open along the inner radius

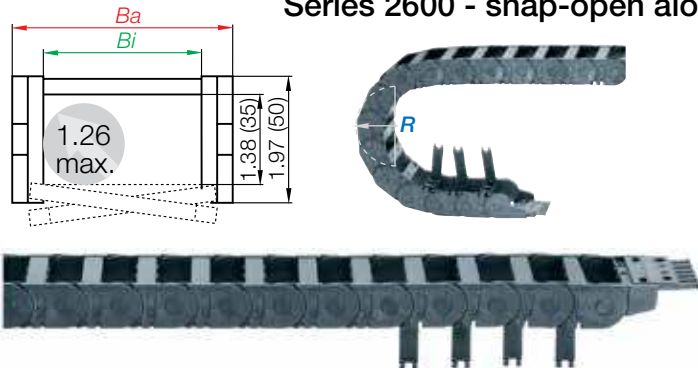

Part Number Structure



Color - Black
Bending radius
Width
Series

Series 2700 - snap-open along the outer radius

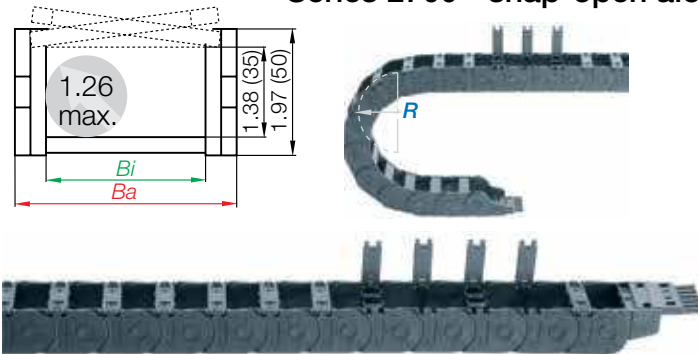

Part Number Structure



Color - Black
Bending radius
Width
Series

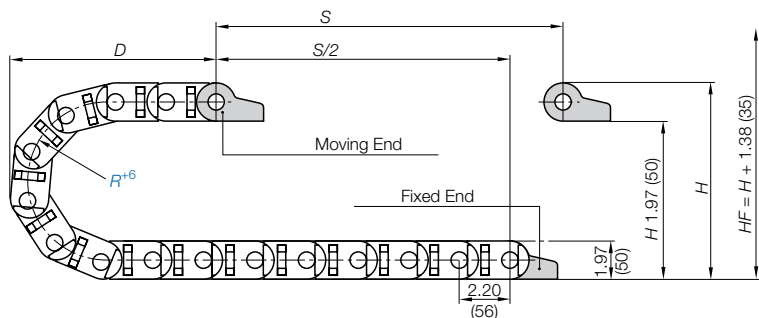

Supplement part number with required radius. Example: 2600-10-100-0
Pitch: 2.20 in. (56 mm) per link links/ft(m) = 5.49 (18)

Part Number.

Snap-open inner radius	Snap-open outer radius	Bi in. (mm)	Ba in. (mm)	Weight lbs/ft (kg/m)
2600-05-□-0	2700-05-□-0	1.97 (50)	2.60 (66)	≈ 0.79 (1.17)
2600-06-□-0	2700-06-□-0	2.56 (65)	3.19 (81)	≈ 0.83 (1.24)
2600-07-□-0	2700-07-□-0	2.95 (75)	3.58 (91)	≈ 0.87 (1.30)
2600-09-□-0	2700-09-□-0	3.54 (90)	4.17 (106)	≈ 0.92 (1.37)
2600-10-□-0	2700-10-□-0	3.94 (100)	4.57 (116)	≈ 0.93 (1.39)
2600-12-□-0	2700-12-□-0	4.92 (125)	5.55 (141)	≈ 0.99 (1.48)
2600-15-□-0	2700-15-□-0	5.91 (150)	6.53 (166)	≈ 1.09 (1.62)
2600-17-□-0	2700-17-□-0	6.89 (175)	7.64 (194)	≈ 1.24 (1.85)

Choose from the radii below for all of the above sizes

Radius (mm) Example: 2400-10-100-0

	063	075	100	125	150	175	200	250
R	2.48 (063)	2.95 (075)	3.94 (100)	4.92 (125)	5.91 (150)	6.89 (175)	7.87 (200)	9.84 (250)
H	6.93 (176)	7.87 (200)	9.84 (250)	11.81 (300)	13.78 (350)	15.75 (400)	17.72 (450)	21.65 (550)
D	6.77 (172)	7.24 (184)	8.23 (209)	9.21 (234)	10.20 (259)	11.18 (284)	12.17 (309)	14.13 (359)
K	12.20 (310)	13.78 (350)	16.93 (430)	19.88 (505)	23.03 (585)	26.18 (665)	29.33 (745)	35.43 (900)

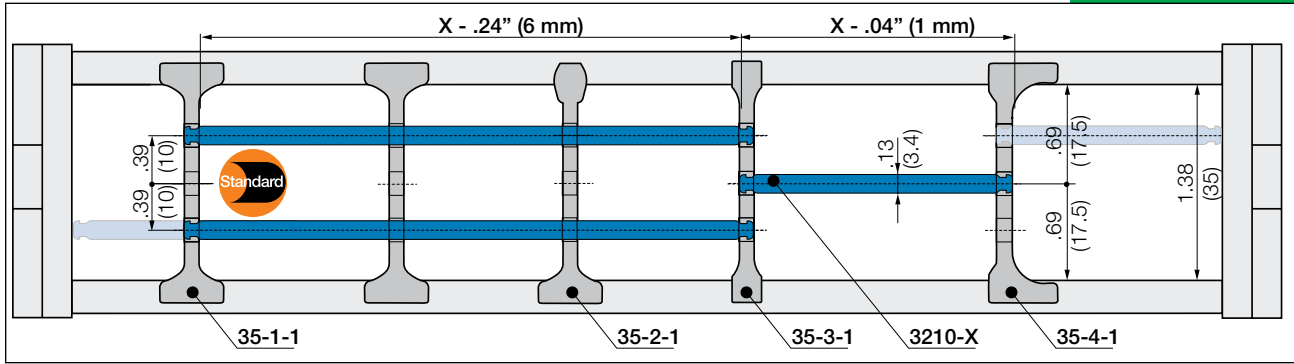

In the standard configuration separators are assembled every 2nd e-chain® link

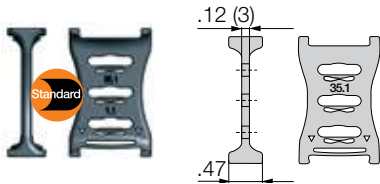

Separator, wide base

Unassembled	Part No. 35.1
Assembled	Part No. 35.1.1

- **Standard separator 35.1 for all applications**

Separator with wide base for maximum locking strength and safe standing in e-chains®.

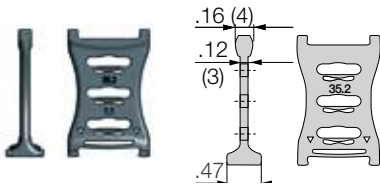

Separator, narrow head

Unassembled	Part No. 35.2
Assembled	Part No. 35.2.1

- **Separator 35.2**

For even faster installation

is used when vertical and horizontal separation is required. Due to its slot, it allows basic vertical/horizontal shelving arrangements.

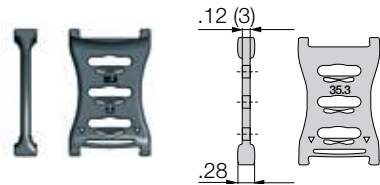

Separator, narrow base

Unassembled	Part No. 35.3
Assembled	Part No. 35.3.1

- **Separator 35.3**

For many thin cables

is used when vertical and horizontal separation is required. Due to its slot, it allows basic vertical/horizontal shelving arrangements.

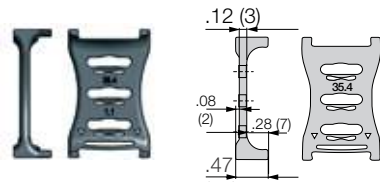

Separator, asymmetrical

Unassembled	Part No. 35.4
Assembled	Part No. 35.4.1

- **Separator 35.4**

For side mounted applications

is used when vertical and horizontal separation is required. Due to its slot, it allows basic vertical/horizontal shelving arrangements.

Lockable full-width shelves - for the standard interior separation

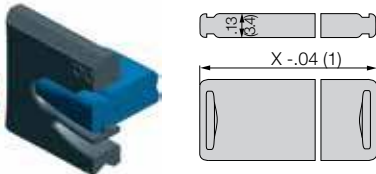

Full width shelf, lockable

Unassembled	Part No. 3200-X
Assembled	Part No. 3210-X

- **Full width shelf, lockable**

is used when vertical and horizontal separation is required. .

Width X in. (mm)	Part No. Unassembled	Part No. Assembled	Width X in. (mm)	Part No. Unassembled	Part No. Assembled
1.97 (050)	3200-50	3210-50	5.91 (150)	3200-150	3210-150
2.95 (075)	3200-75	3210-75	6.89 (175)	3200-175	3210-175
3.94 (100)	3200-100	3210-100	7.87 (200)	3200-200	3210-200
4.53 (115)	3200-115	3210-115	8.86 (225)	3200-225	3210-225
4.92 (125)	3200-125	3210-125	9.84 (250)	3200-250	3210-250



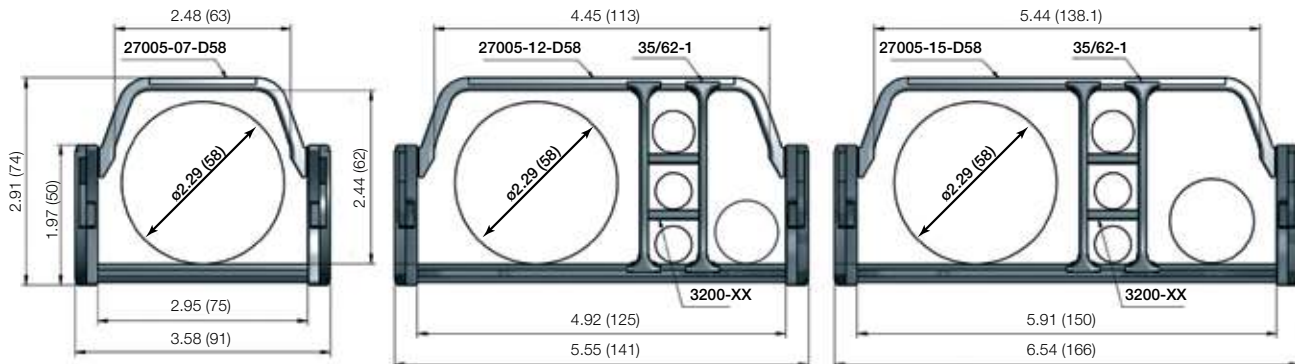

Part Number.

Extender crossbars
for e-chains®
that snap-open
along **inner** radius

Extender crossbars
for e-chains®
that snap-open
along **outer** radius

				<i>Bi</i>	<i>Ba</i>
				in. (mm)	in. (mm)
2600-07D58-	<input type="checkbox"/> -0	2700-07D58-	<input type="checkbox"/> -0	2.95 (75)	3.58 (91)
2600-12D58-	<input type="checkbox"/> -0	2700-12D58-	<input type="checkbox"/> -0	4.92 (125)	5.55 (141)
2600-15D58-	<input type="checkbox"/> -0	2700-15D58-	<input type="checkbox"/> -0	5.91 (150)	6.54 (166)

Choose from the radii below for all of the above sizes

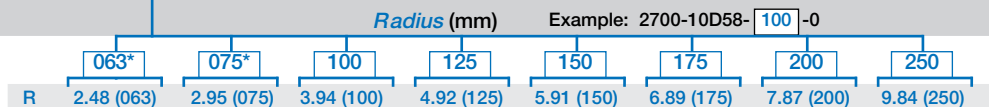

*Radius 063 and 075 only available for 2700 series

Interior separation for extender crossbars

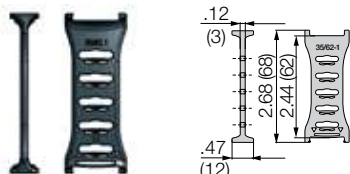

Separator, wide base

Unassembled	Part No. 35/62-1
Assembled	Part No. 35/62-1-1

- **Standard separator 35/62-1, wide base**
For maximum locking strength and safe standing. In standard configuration separators are assembled every 2nd e-chain® link.

Lockable full-width shelves - for the standard interior separation

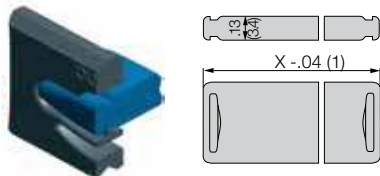

Full width shelf, lockable

Unassembled	Part No. 3200-X
Assembled	Part No. 3210-X

- **Full width shelf, lockable**
is used when vertical and horizontal separation is required. Due to its slot, it allows basic vertical/horizontal shelving arrangements.

Width X	Part No.	Part No.	Width X	Part No.	Part No.
in. (mm)	Unassembled	Assembled	in. (mm)	Unassembled	Assembled
1.97 (050)	3200-50	3210-50	5.91 (150)	3200-150	3210-150
2.95 (075)	3200-75	3210-75	6.89 (175)	3200-175	3210-175
3.94 (100)	3200-100	3210-100	7.87 (200)	3200-200	3210-200
4.53 (115)	3200-115	3210-115	8.86 (225)	3200-225	3210-225
4.92 (125)	3200-125	3210-125	9.84 (250)	3200-250	3210-250

Separator with integrated strain relief

Strain relief separator Part No. 262-Z can be integrated into the mounting bracket and can be placed there at any point of the e-chain®. It combines strain relief and interior separation, it can be installed on the first or last e-chain® link and is easy to assemble without any screws.



For more information ► Chapter 10, Strain Relief

e-chain system® E2/000

Series 2600/2700

Mounting Bracket - Plastic



2600
2700

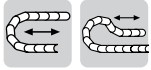

Option 1: pivoting

- For unsupported and gliding applications
- Well suited for tight installation conditions
- Detachable strain relief tiwrap plates
- Can be mounted on the fixed and/or moving end

Moving end
26...3PZB

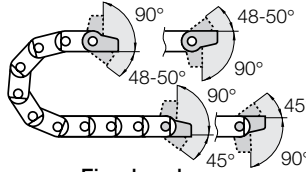

Fixed end
26...4PZB

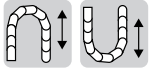
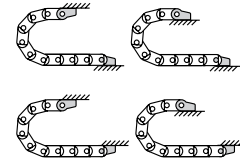

Option 2: locking

- For unsupported and gliding applications
- Extreme speed and/or accelerations
- For height restricted applications
- Can be mounted on the fixed and/or moving end

Moving end
26...1PZB

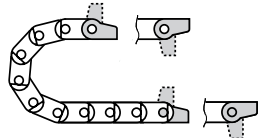

Fixed end
26...2PZB

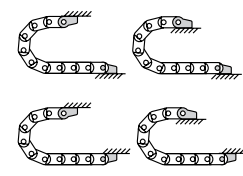

Part Number Structure

2605- 34 PZB K1

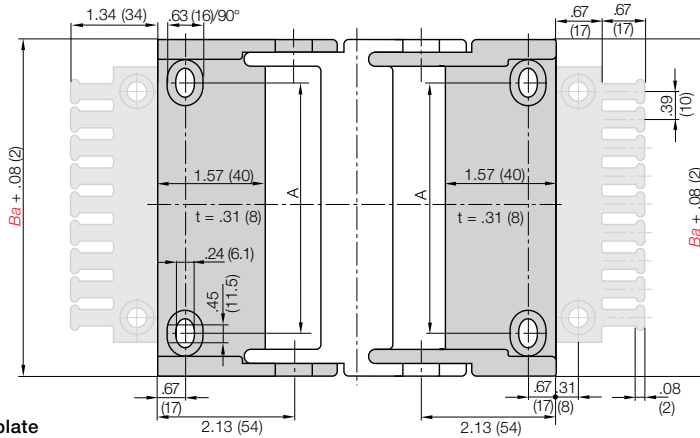
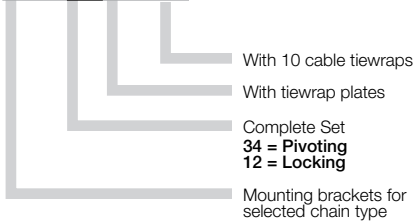

Full set, for both ends:

2605- [34] [PZB] Full set, each part with pin/bore + tiwrap plate

Single-part order:

2605- [3] [PZB] Mounting bracket with bore + tiwrap plate

2605- [4] [PZB] Mounting bracket with pin + tiwrap plate

Part No. Full Set (pivoting)

With Tiwrap Plates

Series 2600:

2605-34PZB

Part No. Full Set (locking)

With Tiwrap Plates + 10 cable ties

Series 2600:

2605-34PZBK1

For Chain Type	Part No. Full Set without Tiwrap Plate	Part No. Full Set with Tiwrap Plate	Part No. Full Set with Tiwrap Plate + 10 cable ties	Dimension A in. (mm)	Number of Teeth
2600/2700-05	2605- [] PZ	2605- [] PZB	2605- [] PZBK1	1.18 (30)	5
2600/2700-06	2606- [] PZ	2606- [] PZB	2606- [] PZBK1	1.77 (45)	5
2600/2700-07	2607- [] PZ	2607- [] PZB	2607- [] PZBK1	2.17 (55)	7
2600/2700-09	2609- [] PZ	2609- [] PZB	2609- [] PZBK1	2.76 (70)	9
2600/2700-10	2610- [] PZ	2610- [] PZB	2610- [] PZBK1	3.15 (80)	10
2600/2700-12	2612- [] PZ	2612- [] PZB	2612- [] PZBK1	4.13 (105)	12
2600/2700-15	2615- [] PZ	2615- [] PZB	2615- [] PZBK1	5.12 (130)	15
2600/2700-17	2617- [] PZ	2617- [] PZB	2617- [] PZBK1	6.10 (155)	17

34 or 12

For pivoting brackets choose 34

For locking brackets choose 12

Example: 2605- [34] PZB

PDF: igus.com/e-chain-pdfs
Product information: igus.com/e-chains



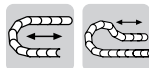

Option 1: pivoting

- For unsupported applications
- Bolted connection outside of chain cross section
- Confined installation conditions
- Attachment points on all sides
- Stackable

Moving end
26001...1

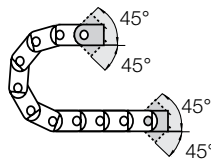

Fixed end
26001...2

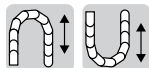
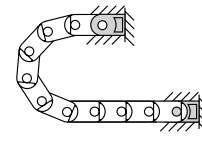

Option 2: locking

- For vertical hanging/standing applications
- Bolted connection outside of chain cross section
- For very high speeds and accelerations
- Attachment points on all sides
- Stackable

Moving end
26101...1

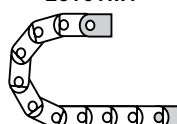

Fixed end
26101...2

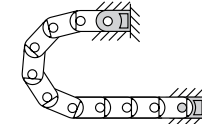

Part Number Structure

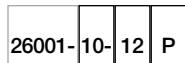

- With profile rail
- Complete Set
- Width
- Mounting brackets for selected chain type
26001 = Pivoting
26101 = Locking

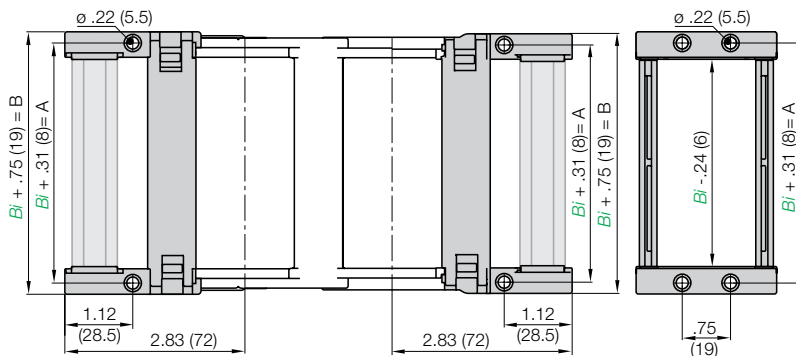

Full set, for both ends:

26001-12 P Full set, each part with pin/bore + profile rail

Single-part order:

26001-1 P Mounting bracket with bore + profile rail

26001-2 P Mounting bracket with pin + profile rail

Part No. Full Set (pivoting)

With Profile Rail
Series 2600/2700:
26001-Width-12P

Part No. Full Set (pivoting)

Without Profile Rail
Series 2600/2700:
26001-Width-12

For Chain Type	Part No. Full set with Profile Rail	Part No. Full Set without Profile Rail	Dimension A in. (mm)	Dimension B in. (mm)
2600/2700-05	-05-12P	-05-12	2.28 (58)	2.72 (69)
2600/2700-06	-06-12P	-06-12	2.87 (73)	3.31 (84)
2600/2700-07	-07-12P	-07-12	3.27 (83)	3.70 (94)
2600/2700-09	-09-12P	-09-12	3.86 (98)	4.29 (109)
2600/2700-10	-10-12P	-10-12	4.25 (108)	4.69 (119)
2600/2700-12	-12-12P	-12-12	5.24 (133)	5.67 (144)
2600/2700-15	-15-12P	-15-12	6.22 (158)	6.65 (169)
2600/2700-17	-17-12P	-17-12	7.20 (183)	7.64 (194)

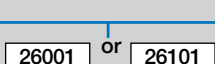

For pivoting brackets choose **26001**
For locking brackets choose **26101**
Example: **26001**-10-12P

e-chain system® E2/000
 Series 2600/2700
 Mounting Bracket - Steel



2600
 2700

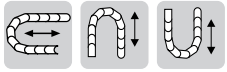

Option 1: Steel

- One part (two-piece) for all chain widths
- Electrically conductive
- Bolted connection outside of chain cross-section possible

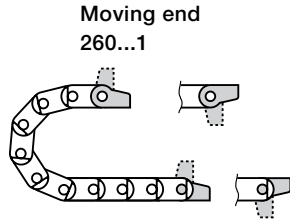

Fixed end
 260...2

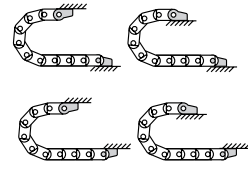

Possible installation configurations -

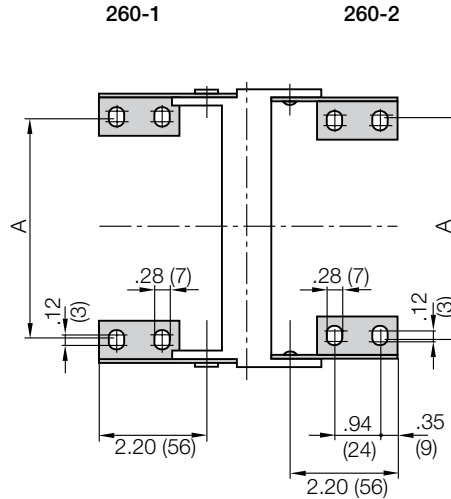
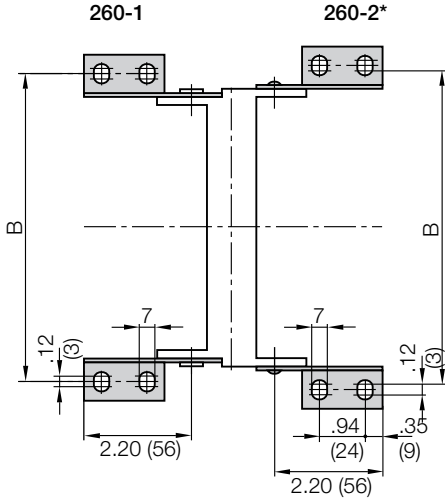

*pivoting with no stop, (360°)

Chain Type	Part No. Full Set	Dimension A		Dimension B	
		in.	(mm)	in.	(mm)
2600/2700-05	260-12	1.46	(37)	3.27	(83)
2600/2700-07	260-12	2.44	(62)	4.25	(108)
2600/2700-10	260-12	3.43	(87)	5.24	(133)
2600/2700-12	260-12	4.41	(112)	6.22	(158)

Part No. Mounting Brackets Full Set
 4 parts, 2 with pin, 2 with bore
 Series 2680:
260-12

Part No. Mounting Bracket Moving End
 2 parts, 1 left & 1 right
 Series 2680:
260-1

Part No. Mounting Bracket Fixed End
 2 parts, 1 left & 1 right
 Series 2680:
260-2

PDF: igus.com/e-chain-pdfs
 Product information: igus.com/e-chains



Chainfix clamps for the profile rail



igus® Chainfix strain relief elements are available in either steel or stainless steel. They can be adjusted with a hexagon socket and are available in single, double and triple configurations.

Part No. Single Clamp		Part No. Double Clamp		Part No. Triple Clamp		Cable ø	
Steel	Stainless	Steel	Stainless	Steel	Stainless	in.	(mm)
CFX12-1	CFX12-1E	CFX12-2	CFX12-2E	CFX12-3	-	.24 - .47	(06 - 12)
CFX14-1	CFX14-1E	CFX14-2	CFX14-2E	CFX14-3	-	.47 - .55	(12 - 14)
CFX16-1	CFX16-1E	CFX16-2	CFX16-2E	CFX16-3	-	.55 - .63	(14 - 16)
CFX18-1	CFX18-1E	CFX18-2	CFX18-2E	CFX18-3	-	.63 - .71	(16 - 18)
CFX20-1	CFX20-1E	CFX20-2	CFX20-2E	CFX20-3	-	.71 - .79	(18 - 20)
CFX22-1	CFX22-1E	CFX22-2	CFX22-2E	CFX22-3	-	.79 - .87	(20 - 22)
CFX26-1	CFX26-1E	CFX26-2	CFX26-2E	-	-	.87 - 1.02	(22 - 26)
CFX30-1	CFX30-1E	CFX30-2	CFX30-2E	-	-	1.02 - 1.18	(26 - 30)
CFX34-1	CFX34-1E	CFX34-2	CFX34-2E	-	-	1.18 - 1.34	(30 - 34)
CFX38-1	CFX38-1E	-	-	-	-	1.34 - 1.50	(34 - 38)
CFX42-1	CFX42-1E	-	-	-	-	1.50 - 1.65	(38 - 42)

For more information please refer to strain relief section of Chapter 10

Tiewrap Plates

**Option 1:
Tiewrap plates as an individual part**

Available as an individual component, can be fixed onto a mounting bracket with the use of a profile rail.

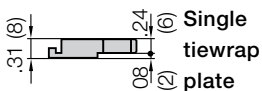
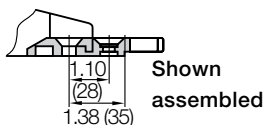

Tiewrap Plate	n Number of Teeth	C Overall Width in. (mm)	B Bore Width in. (mm)	Center Bore
3050-ZB	5	1.97 (50)	1.18 (30)	no
3075-ZB	7	2.95 (75)	2.16 (55)	no
3100-ZB	10	3.94 (100)	3.15 (80)	no
3115-ZB	11	4.53 (115)	3.74 (95)	no
3125-ZB	12	4.92 (125)	4.13 (105)	no
3150-ZB	15	5.91 (150)	5.12 (130)	no
3175-ZB	17	6.89 (175)	6.10 (155)	no
3200-ZB	20	7.87 (200)	7.09 (180)	yes
3225-ZB	22	8.86 (225)	8.07 (205)	yes
3250-ZB	25	9.84 (250)	9.06 (230)	yes

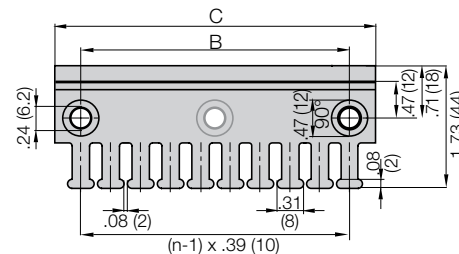

For more information please refer to strain relief section of Chapter 10



**Option 2:
Clip-on Tiewrap plates**

Available as a clip-on tiewrap plate without the use of bolts. They are inserted and removed with a screwdriver used as a lever. Clip-on tiewrap plates are also available as an attachment to the opening crossbars.

Part No.	Number of Teeth	Width of Strain Relief in. (mm)
3050-ZC	5	1.97 (50)
3075-ZC	7	2.95 (75)

For more information please refer to strain relief section of Chapter 10

Strain relief for steel mounting brackets

Clip-on connection is not possible with steel mounting brackets. In this case, the tiewrap plates must be bolted directly into separate bore holes in front of the mounting bracket. Alternatively the tiewrap plates 30XX-Z and ZS can be also used here. Details chapter 10

e-chain system® E2/000

Series 2600/2700

Strain Relief



2600
2700

Guide troughs are used with applications where the upper run of the e-chain® glides on the lower run. If using igus® steel guide troughs, the following components are required:

- Full travel length of guide trough
Part Number 95-30
- 1/2 travel length of glide bars
Part number 92-01
- Installation sets as end connectors
Part Number 95-50-XX

-XX indicates the length of the profile rail on which the guide trough is mounted. The values and part numbers are specified in the table on the left. The standard length of the trough components and glide bars is 6.56 ft (2 m.) The required overall length of the guide trough directly correlates to the length of travel.

Example:

Length of travel 164 ft (50 m)
Center mounted

Required guide troughs:

164 ft (50 m) guide trough
82 ft (25 m) glide bar
= 25 sections of 6.56 ft (2 m) guide trough

Part No. 95-30

= 13 sections of 6.56 ft (2 m) glide bar

Part No. 92-01

Required number of installation sets:

= Number of guide trough components + 1
= 25 + 1 = 26

Part number of the installation sets

Example: 95-50-400 for 15.75" (400 mm) long profile rail.



Width of Crossbar
2700-05-200-0

	B_{Ri}	Installation Part No.
-05	2.80 (71)	95-50-200
-06	3.38 (86)	95-50-200
-07	3.78 (96)	95-50-225
-09	4.37 (111)	95-50-225
-10	4.76 (121)	95-50-250
-12	5.75 (146)	95-50-275
-15	6.73 (171)	95-50-300
-17	7.83 (199)	95-50-325

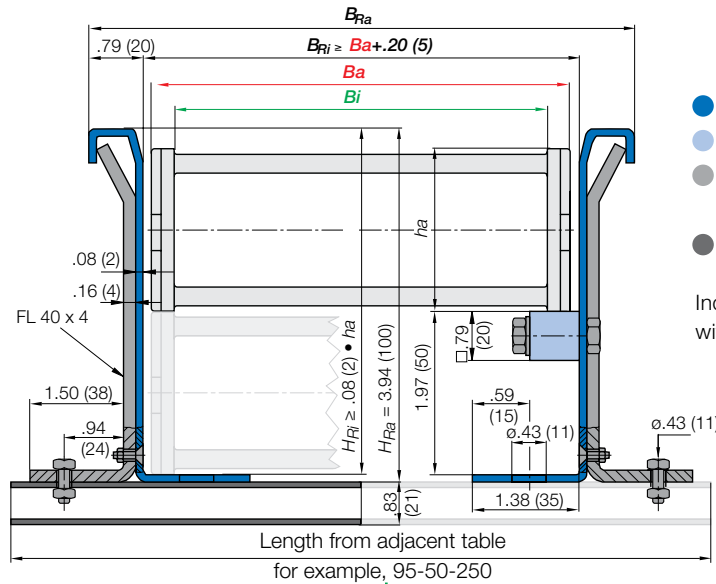

- Guide trough
- Glide bars
- Installation set "Basic"
- Profile rail

Individual attachment without profile rail

* Specialized guide trough available upon request

Standard length profile rail

PDF: igus.com/e-chain-pdfs
Product information: igus.com/e-chains

