

L-BAND 4 W HIGH POWER SPDT SWITCH

DESCRIPTION

The μ PG2155TB is an L-band SPDT GaAs FET switch which was developed for digital cellular or cordless telephone application. The device can operate from 500 MHz to 2.5 GHz, having the low insertion loss and high linearity.

FEATURES

- Low insertion loss
 - : L_{INS} = 0.35 dB TYP. @ V_{cont} = +2.6 V/0 V, f = 1.0 GHz
 - : L_{INS} = 0.40 dB TYP. @ V_{cont} = +2.6 V/0 V, f = 2.0 GHz
 - : L_{INS} = 0.45 dB TYP. @ V_{cont} = +2.6 V/0 V, f = 2.5 GHz
- High linearity
 - : 2f₀ = 70 dBc TYP. @ V_{cont} = +2.6 V/0 V, f = 0.9 GHz, P_{in} = +34.5 dBm
 - : 3f₀ = 75 dBc TYP. @ V_{cont} = +2.6 V/0 V, f = 0.9 GHz, P_{in} = +34.5 dBm
- 6-pin super minimold package (2.1 × 2.0 × 0.9 mm)

APPLICATION

- GSM Triple/Quad band digital cellular

ORDERING INFORMATION

Part Number	Order Number	Package	Marking	Supplying Form
μ PG2155TB-E4	μ PG2155TB-E4-A	6-pin super minimold (Pb-Free)	G4R	<ul style="list-style-type: none"> • Embossed tape 8 mm wide • Pin 4, 5, 6 face the perforation side of the tape • Qty 3 kpcs/reel

Remark To order evaluation samples, contact your nearby sales office.
 Part number for sample order: μ PG2155TB-A

Caution: Observe precautions when handling because these devices are sensitive to electrostatic discharge

The information in this document is subject to change without notice. Before using this document, please confirm that this is the latest version.

<R> PIN CONNECTIONS

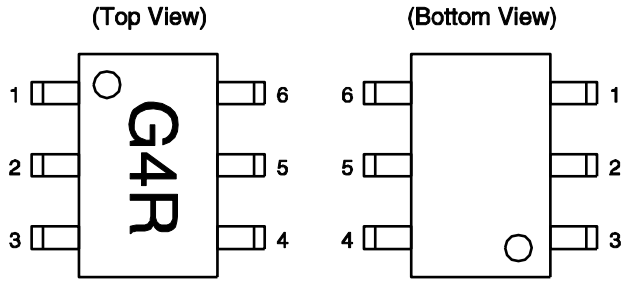

Pin No.	Pin Name
1	RF2
2	GND
3	RF3
4	V _{cont2}
5	RF1
6	V _{cont1}

ABSOLUTE MAXIMUM RATINGS (T_A = +25°C)

Parameter	Symbol	Ratings	Unit
Control Voltage	V _{cont}	+6.0	V
Input Power	P _{in}	+38	dBm
Operating Ambient Temperature	T _A	-45 to +85	°C
Storage Temperature	T _{stg}	-55 to +150	°C

RECOMMENDED OPERATING RANGE (T_A = +25°C)

Parameter	Symbol	MIN.	TYP.	MAX.	Unit
Control Voltage (High)	V _{cont (H)}	+2.4	+2.6	+5.0	V
Control Voltage (Low)	V _{cont (L)}	-0.2	0	+0.2	V

ELECTRICAL CHARACTERISTICS (T_A = +25°C, V_{cont} = +2.6 V/0 V, Z_o = 50 Ω, off chip DC blocking capacitors value: 56 pF, unless otherwise specified)

Parameter	Symbol	Test Conditions	MIN.	TYP.	MAX.	Unit
Insertion Loss	L _{INS}	f = 0.5 to 1.0 GHz	–	0.35	0.45	dB
		f = 1.0 to 2.0 GHz	–	0.40	0.50	dB
		f = 2.0 to 2.5 GHz	–	0.45	0.55	dB
Isolation	ISL	f = 0.5 to 1.0 GHz	22	24	–	dB
		f = 1.0 to 2.0 GHz	17	19	–	dB
		f = 2.0 to 2.5 GHz	15	17	–	dB
Input Return Loss	RL _{in}	f = 0.5 to 2.5 GHz	15	20	–	dB
Output Return Loss	RL _{out}	f = 0.5 to 2.5 GHz	15	20	–	dB
<R> 0.1 dB Loss Compression	P _{in (0.1 dB)}	f = 0.9 GHz	–	37.5	–	dBm
Input Power		f = 1.8 GHz	–	37.5	–	dBm
<R> 2nd Harmonics	2f ₀	f = 0.9 GHz, P _{in} = +34.5 dBm	65	70	–	dBc
		f = 1.8 GHz, P _{in} = +31.5 dBm	64	70	–	dBc
<R> 3rd Harmonics	3f ₀	f = 0.9 GHz, P _{in} = +34.5 dBm	65	75	–	dBc
		f = 1.8 GHz, P _{in} = +31.5 dBm	64	75	–	dBc
Switching Speed	t _{sw}		–	1	5	μs
Control Current	I _{cont}	RF Non	–	0.5	5.0	μA

<R> **EVALUATION CIRCUIT**

Off chip DC blocking capacitors value C1 = 56 pF, C2 = 1 000 pF (Bypass), using standard evaluation board.

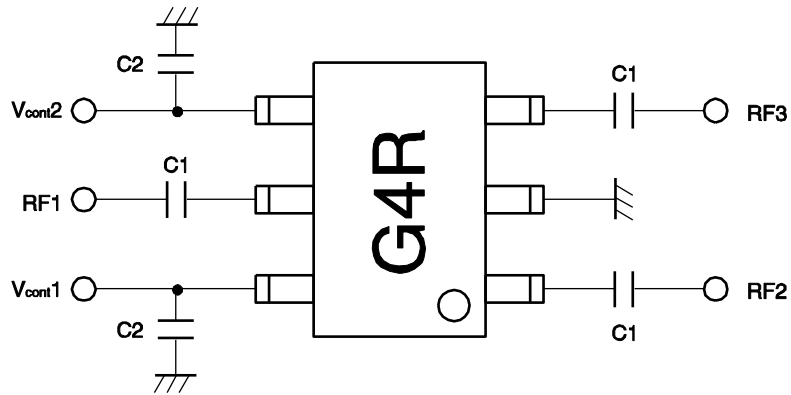

The application circuits and their parameters are for reference only and are not intended for use in actual design-ins.

<R> **TRUTH TABLE**

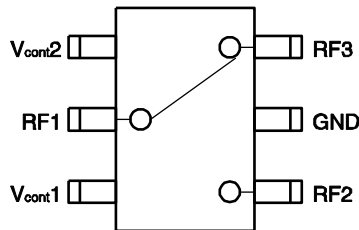

V _{cont1}	V _{cont2}	RF1-RF2	RF1-RF3
High	Low	ON	OFF
Low	High	OFF	ON

<R> PACKAGE DIMENSIONS

6-PIN SUPER MINIMOLD (UNIT: mm)

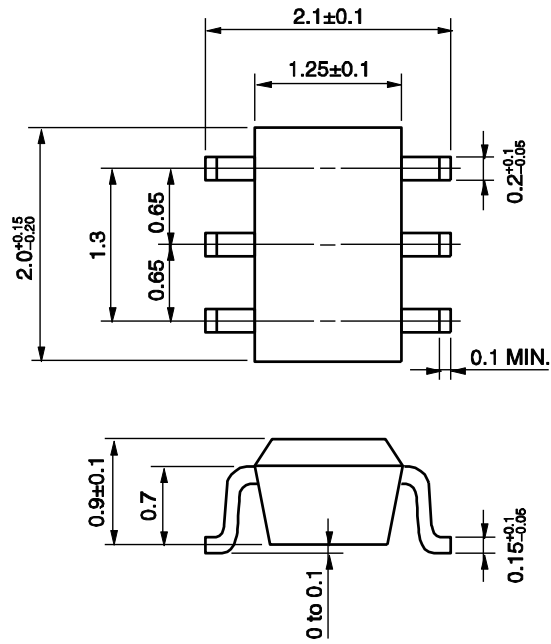

RECOMMENDED SOLDERING CONDITIONS

This product should be soldered and mounted under the following recommended conditions. For soldering methods and conditions other than those recommended below, contact your nearby sales office.

Soldering Method	Soldering Conditions	Condition Symbol
Infrared Reflow	Peak temperature (package surface temperature) : 260°C or below Time at peak temperature : 10 seconds or less Time at temperature of 220°C or higher : 60 seconds or less Preheating time at 120 to 180°C : 120±30 seconds Maximum number of reflow processes : 3 times Maximum chlorine content of rosin flux (% mass) : 0.2%(Wt.) or below	IR260
Wave Soldering	Peak temperature (molten solder temperature) : 260°C or below Time at peak temperature : 10 seconds or less Preheating temperature (package surface temperature) : 120°C or below Maximum number of flow processes : 1 time Maximum chlorine content of rosin flux (% mass) : 0.2%(Wt.) or below	WS260
Partial Heating	Peak temperature (terminal temperature) : 350°C or below Soldering time (per side of device) : 3 seconds or less Maximum chlorine content of rosin flux (% mass) : 0.2%(Wt.) or below	HS350

Caution Do not use different soldering methods together (except for partial heating).

<p>Caution</p>	<p>GaAs Products</p>	<p>This product uses gallium arsenide (GaAs). GaAs vapor and powder are hazardous to human health if inhaled or ingested, so please observe the following points.</p> <ul style="list-style-type: none"> • Follow related laws and ordinances when disposing of the product. If there are no applicable laws and/or ordinances, dispose of the product as recommended below. <ol style="list-style-type: none"> 1. Commission a disposal company able to (with a license to) collect, transport and dispose of materials that contain arsenic and other such industrial waste materials. 2. Exclude the product from general industrial waste and household garbage, and ensure that the product is controlled (as industrial waste subject to special control) up until final disposal. <ul style="list-style-type: none"> • Do not burn, destroy, cut, crush, or chemically dissolve the product. • Do not lick the product or in any way allow it to enter the mouth.
-----------------------	----------------------	---