

SNDH-T SERIES

000641
Issue 7

Quadrature Speed and Direction Sensors

DESCRIPTION

The SNDH-T Series is a dual differential Hall-effect sensor that provides speed and direction information using a quadrature output with signals 90° phase shifted from each other. Target direction is determined by output lead/lag phase shifting. This product is designed for applications where extremely high resolution is required at wide frequency ranges, 1 Hz to 15 kHz and large air gaps. BiCMOS (bipolar complementary metal-oxide-semiconductor). Hall-effect technology, using advanced digital signal processing for dynamic off-set cancellation, provides enhanced air gap performance and phase shift accuracy over most conditions.

Unique patented (pending) IC (integrated circuit) packaging provides output phase shift tolerancing with enhanced accuracy. The robust package is automotive under-the-hood grade for most environmental conditions, as well as EMI (electromagnetic interference) hardened. Multiple connection options are available. Package design includes an O-ring seal for pressure applications and a fixed mounting flange.

FEATURES

- Hall-effect magnetic sensing technology
- Dual differential Hall provides enhanced target resolution
- Advanced performance dynamic offset self calibration
- Air gap up to 2 mm [0.08 in]
- Near zero speed
- Automotive under-the-hood packaging integrity
- EMI hardened
- High frequency switching capability: 1 Hz to 15 kHz
- Wide operating temperature range: -40°C to 150°C [-40°F to 302°F]
- Multiple connector options
- Short circuit protection
- Reverse voltage protection
- Open collector output
- Low jitter output
- O-ring seal

POTENTIAL TRANSPORTATION APPLICATIONS

- Steering position
- Tachometers/counters
- Encoders
- Speed and direction of gears and shafts in transmissions, hydraulic motors, pumps and gear boxes

SNDH-T4C-G01



SNDH-T4L-G01



SNDH-T4P-G01



SNDH-T4P-G02



PORTFOLIO



The SNDH-T Series is part of a portfolio of electronic speed and position sensors that use a variety of technologies to detect speed, direction, or position of a moving ferrous metal or magnetic target.

Honeywell

QUADRATURE SPEED AND DIRECTION SENSORS SNDH-T SERIES

TABLE 1. ELECTRICAL SPECIFICATIONS

Characteristic	Parameter	Comment
Voltage: supply max. continuous supply	4.5 V to 18 V	—
	18 V	—
Output signal: type	square wave	Two channel, phase shifted by 90° either channel, may lead or lag/push/pull.
duty cycle ¹	50% ±10%	
phase shift	90° ±20°	See Figures 2, 3, 4, 5 for recommended orientation.
high	≥Vs - 0.5 V	Using recommended target tooth/slot ² .
low	≤0.5 V	See Figures 2, 3, 4, 5 for recommended orientation.
load current	20 mA max.	Applies to each output at all conditions.
rise time	10 us max.	Dependent on load resistor.
fall time	1 us max.	—
frequency	1 Hz to 15 kHz	Frequencies >10 kHz may be dependent on target geometry and air gap.
Short circuit protection	80 mA max.	all conditions
Supply current: normal max.	12 mA	all conditions
	18 mA	
Reverse voltage	-18 V max.	continuous

¹Duty cycle = Time high/time total.

²≥Vpull - up - 0.5 V if not the same as Vs.

TABLE 2. MECHANICAL SPECIFICATIONS

Characteristic	Parameter
Sensing air gap	0,0 mm to 2,0 mm [0.0 in to 0.08 in]
Target: width ¹	>5,0 mm [0.20 in] recommended; 12,7 mm [0.5 in] typ.
slot width ²	2,0 mm [0.08 in] recommended
tooth width ²	2,0 mm [0.08 in] recommended
tooth height ³	>3,0 mm [0.12 in] recommended; 5,0 mm [0.20 in] typ.
Sensor misposition to target	±1.5 mm
Materials: insert	plastic Valox® K4560
housing	304 stainless steel
bushing	brass
O-ring	fluorocarbon (Viton™)
cable ⁵	EVA, four conductor, 36 AWG, 28 strand, Ø5,2 mm [Ø0.20 in] jacket
Mounting: bore size ⁴	Ø15,05 mm to Ø15,15 mm [Ø0.60 in to Ø0.61 in]
torque	10 Nm [88.5 in-lb] max. with M6 X 1.0 bolt

¹Narrower targets may limit axial offsets.

²Other geometry may be suitable.

³Shorter tooth heights may limit maximum air gap performance.

⁴Application dependent.

QUADRATURE SPEED AND DIRECTION SENSORS SNDH-T SERIES

TABLE 3. ENVIRONMENTAL SPECIFICATIONS

Characteristic	Condition	Parameter
EMI: radiated immunity bulk current injection ESD fast transient burst	400 Hz to 2 GHz 20 MHz to 400 MHz against the connector (150 pF, 330 Ohm) EN 60947-5-2/A1:2012	100 V/m 60 mA 16 kV air and 8 kV contact EN61000-4-4 Level 4
Operating temperature	continuous	-40°C to 150°C [-40°F to 302°F]
Thermal shock, air to air	0.5 hr dwell, <105 transition	-40°C to 150°C [-40°F to 302°F]
Humidity	95% humidity at 90°C [194°F]	168 hr
Salt fog	DIN IEC 6872-11	96 hr
Thermal saline dunk	105°C to 0°C [221°F to 32°F] air to liquid, 5% saline	5 dunks
High temperature exposure with power	—	1000 hr at 150°C [302°F]
Mechanical shock	—	50 g
Vibration	—	30 g, 10 Hz to 2 kHz
Sensor degree of protection	—	IP69K
Resistance to fluids	—	general under-the-hood automotive fluids

TABLE 4. CATALOG LISTINGS

Catalog Listing	Description
SNDH-T4C-G01	SNDH-T Series, quadrature speed and direction sensor, stainless steel housing, 45 mm [1.77 in] housing length, integral connector, straight exit,
SNDH-T4L-G01	SNDH-T Series, quadrature speed and direction sensor stainless steel housing, 45 mm [1.77 in] housing length, 555 mm [21.85 in] cable with leads, straight exit,
SNDH-T4P-G01	SNDH-T Series, quadrature speed and direction sensor stainless steel housing, 45 mm [1.77 in] housing length, connector with 203,8 mm [8.02 in] cable, straight exit
SNDH-T4P-G02	SNDH-T Series, quadrature speed and direction sensor, stainless steel housing, 45 mm [1.77 in] housing length, connector with 555 mm [21.85 in] cable, straight exit,

Figure 1. Sensor Output

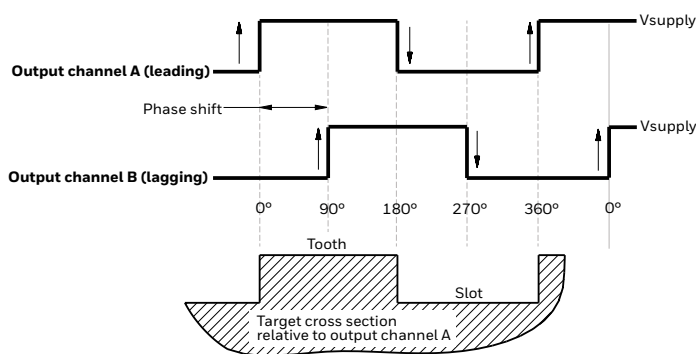
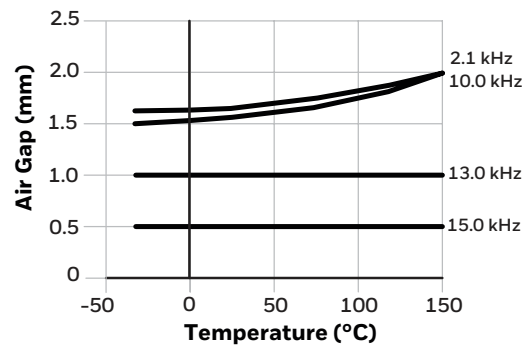
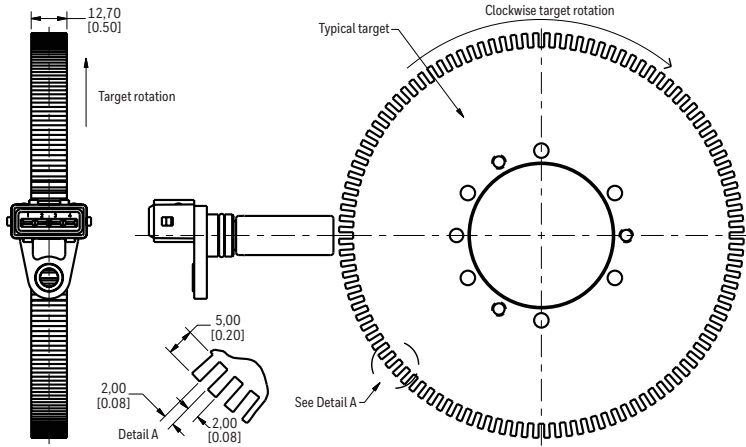

Figure 2. Temperature Air Gap Frequency Derating Curve



QUADRATURE SPEED AND DIRECTION SENSORS SNDH-T SERIES

Figure 3. SNDH-T4C-G01 Dimensional Drawings (For reference only: mm [in])



Circuit Diagram

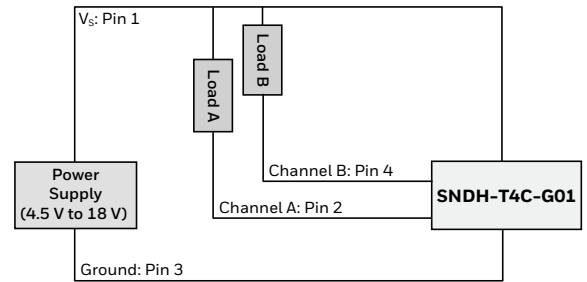

Note: The load resistor values should be such that the output current does not exceed the maximum load current of 20 mA.

Use Ohm's Law to calculate the load resistor based on the supply/load voltage used:

$$R_{load} = V_s / 0.02 A$$

Mating connector:
Amp Superseal 282192

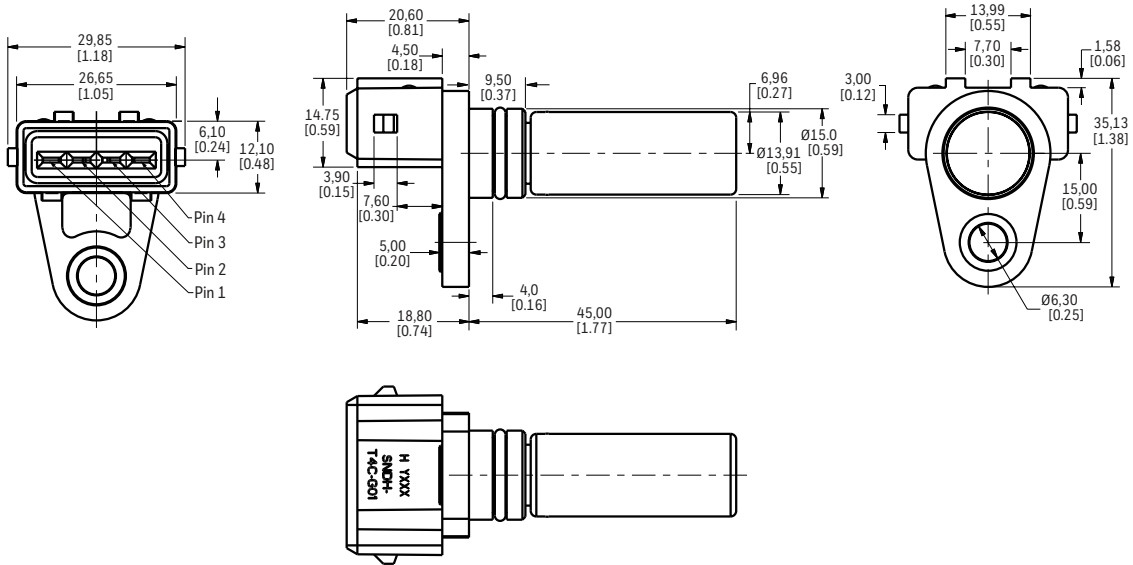
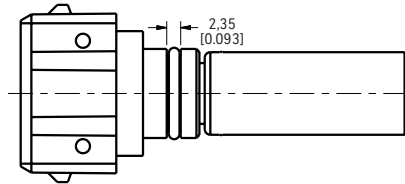

PINOUT			
Pin 1	Pin 2	Pin 3	Pin 4
(+)	Channel A	(-)	Channel B

QUADRATURE SPEED AND DIRECTION SENSORS SNDH-T SERIES

Figure 4. SNDH-T4L-G01 Dimensional Drawings (For reference only: mm [in])

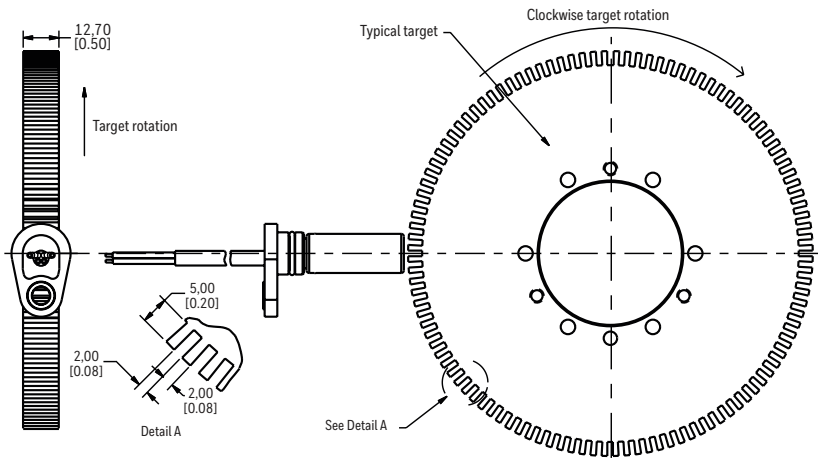

Circuit Diagram

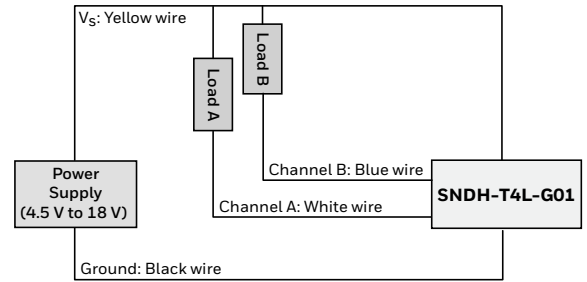

Note: The load resistor values should be such that the output current does not exceed the maximum load current of 20 mA.

Use Ohm's Law to calculate the load resistor based on the supply/load voltage used:

$$R_{\text{load}} = V_s / 0.02 \text{ A}$$

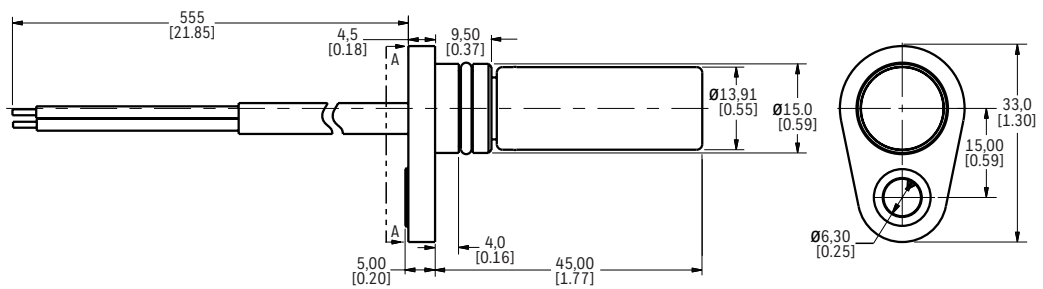
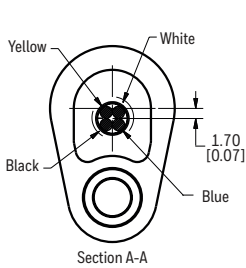
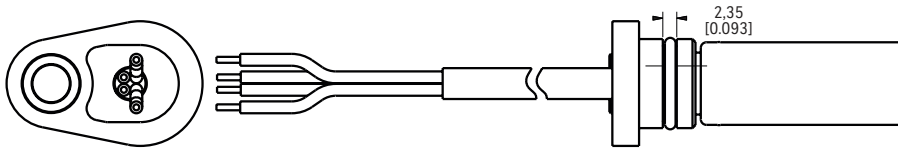

LEADWIRE ASSIGNMENT			
Yellow	Black	White	Blue
(+)	(-)	Channel A	Channel B

QUADRATURE SPEED AND DIRECTION SENSORS SNDH-T SERIES

Figure 5. SNDH-T4P-G01 Dimensional Drawings (For reference only: mm [in])

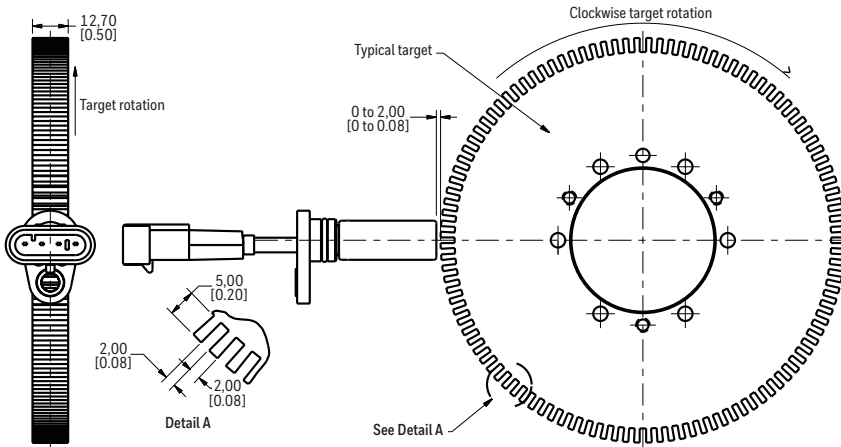

Circuit Diagram

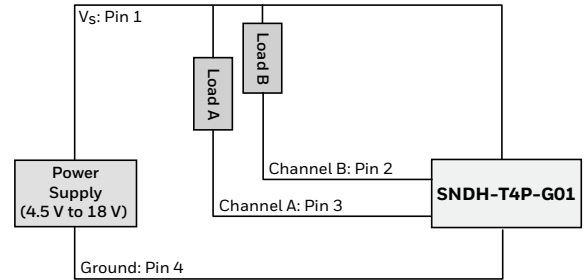

Note: The load resistor values should be such that the output current does not exceed the maximum load current of 20 mA.

Use Ohm's Law to calculate the load resistor based on the supply/load voltage used:

$$R_{load} = V_s / 0.02 A$$

Mating connector:

Amp Superseal 282088

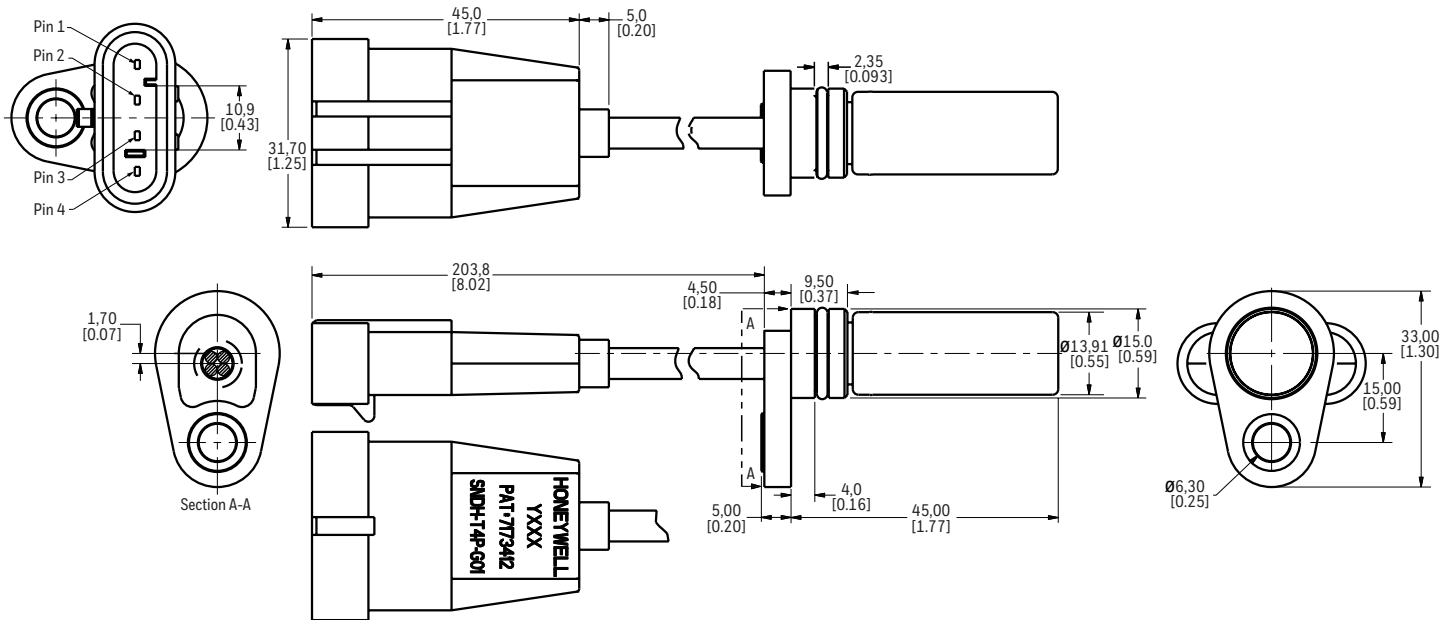

PINOUT

Pin 1	Pin 2	Pin 3	Pin 4
(+)	Channel B	Channel A	(-)

QUADRATURE SPEED AND DIRECTION SENSORS SNDH-T SERIES

Figure 6. SNDH-T4P-G02 Dimensional Drawings (For reference only: mm [in])

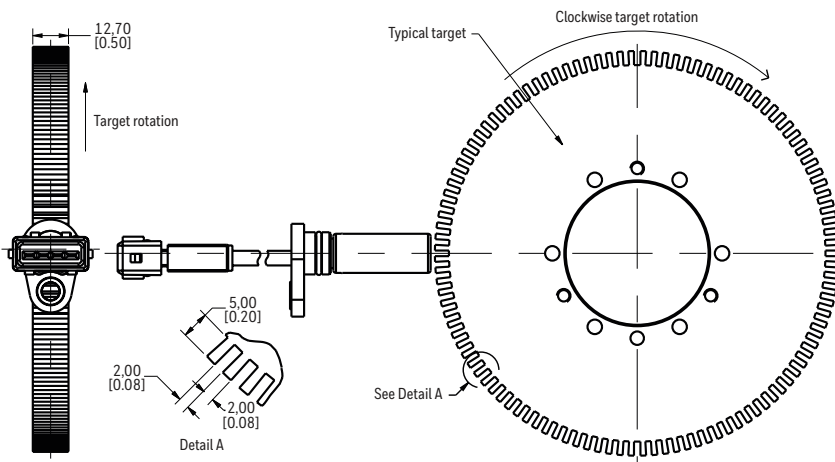

Circuit Diagram

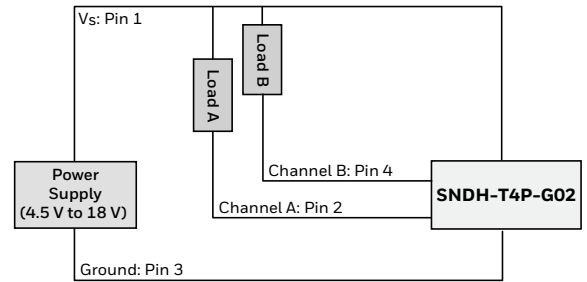

Note: The load resistor values should be such that the output current does not exceed the maximum load current of 20 mA.

Use Ohm's Law to calculate the load resistor based on the supply/load voltage used:

$$R_{load} = V_s / 0.02 A$$

Mating connector:

Amp Superseal 282192

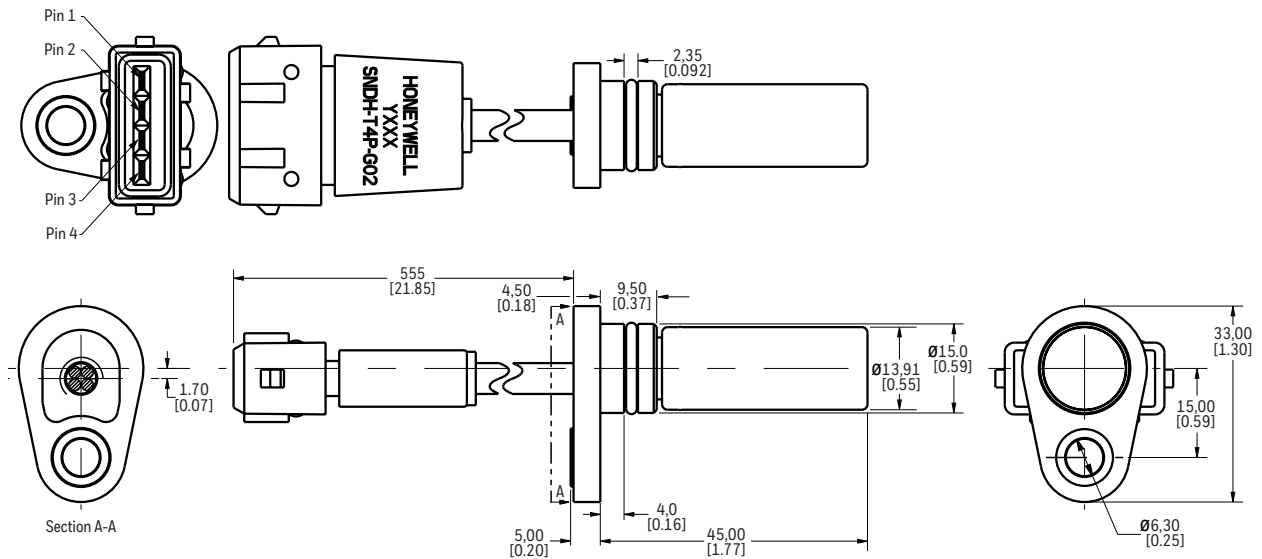

PINOUT			
Pin 1	Pin 2	Pin 3	Pin 4
(+)	Channel A	(-)	Channel B

WARRANTY/REMEDY

Honeywell warrants goods of its manufacture as being free of defective materials and faulty workmanship during the applicable warranty period. Honeywell's standard product warranty applies unless agreed to otherwise by Honeywell in writing; please refer to your order acknowledgment or consult your local sales office for specific warranty details. If warranted goods are returned to Honeywell during the period of coverage, Honeywell will repair or replace, at its option, without charge those items that Honeywell, in its sole discretion, finds defective. **The foregoing is buyer's sole remedy and is in lieu of all other warranties, expressed or implied, including those of merchantability and fitness for a particular purpose. In no event shall Honeywell be liable for consequential, special, or indirect damages.**

While Honeywell may provide application assistance personally, through our literature and the Honeywell web site, it is buyer's sole responsibility to determine the suitability of the product in the application.

Specifications may change without notice. The information we supply is believed to be accurate and reliable as of this writing. However, Honeywell assumes no responsibility for its use.

FOR MORE INFORMATION

Honeywell Sensing and Safety Technologies services its customers through a worldwide network of sales offices and distributors. For application assistance, current specifications, pricing or the nearest Authorized Distributor, visit sps.honeywell.com/ast or call:

USA/Canada	+1 302 613 4491
Latin America	+1 305 805 8188
Europe	+44 1344 238258
Japan	+81 (0) 3-6730-7152
Singapore	+65 6355 2828
Greater China	+86 4006396841

Honeywell Sensing and Safety Technologies

830 East Arapaho Road
Richardson, TX 75081
sps.honeywell.com/ast

Valox® is a registered trademark of Sabic Global Technologies B.V.
Viton™ is a trademark The Chemours Company FC, LLC.

000641-7-EN | 7 | 10/22
© 2022 Honeywell International Inc. All rights reserved.

⚠ WARNING PERSONAL INJURY

DO NOT USE these products as safety or emergency stop devices or in any other application where failure of the product could result in personal injury.

Failure to comply with these instructions could result in death or serious injury.

⚠ WARNING MISUSE OF DOCUMENTATION

- The information presented in this product sheet is for reference only. Do not use this document as a product installation guide.
- Complete installation, operation, and maintenance information is provided in the instructions supplied with each product.

Failure to comply with these instructions could result in death or serious injury.

Honeywell