

PRODUCT NO.	DIM. A	DIM. B	REMARK
10120214-002LF		NA	OBSOLETE
10120214-003LF	4.00	3.48	
10120214-004LF	3.90	3.38	

$\triangle B$
$\triangle B$

A

B

C

D

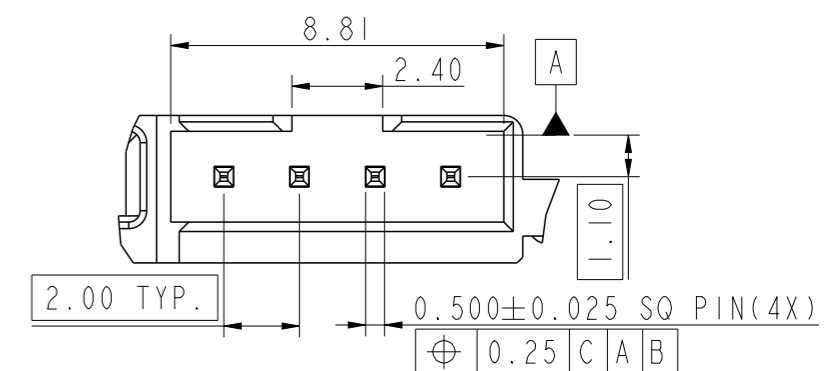
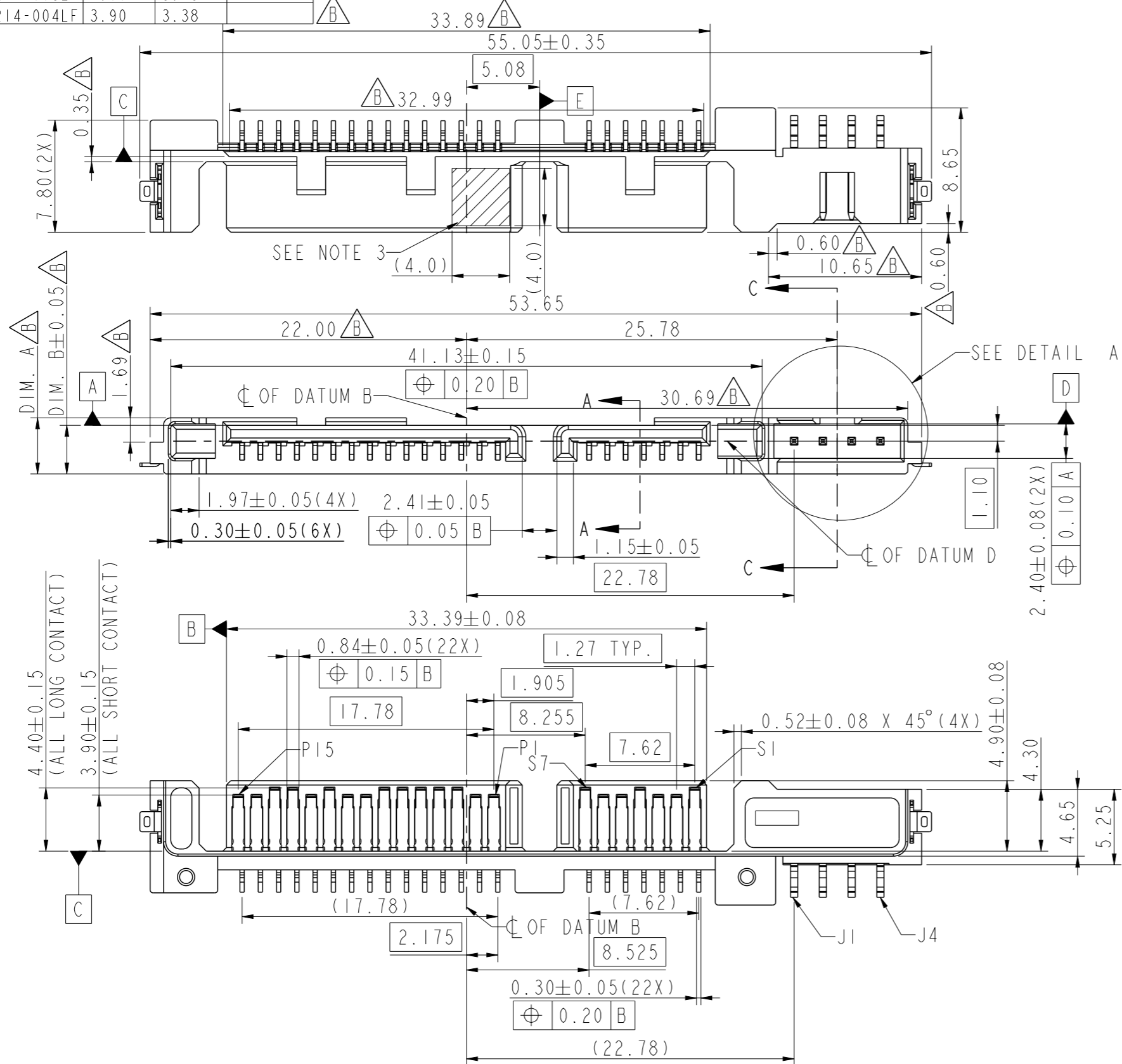

DETAIL A
SCALE 5.000

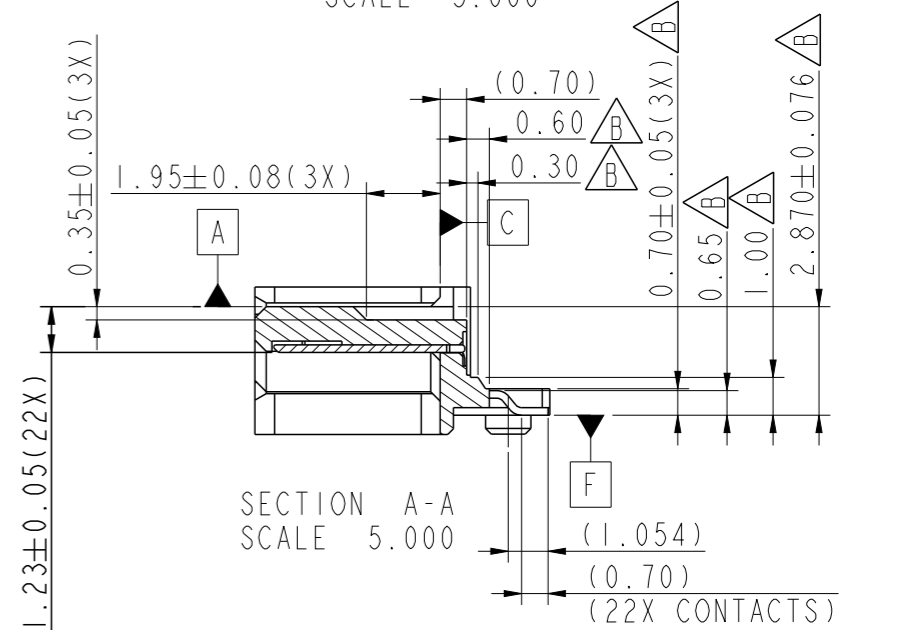

SECTION A-A
SCALE 5.000

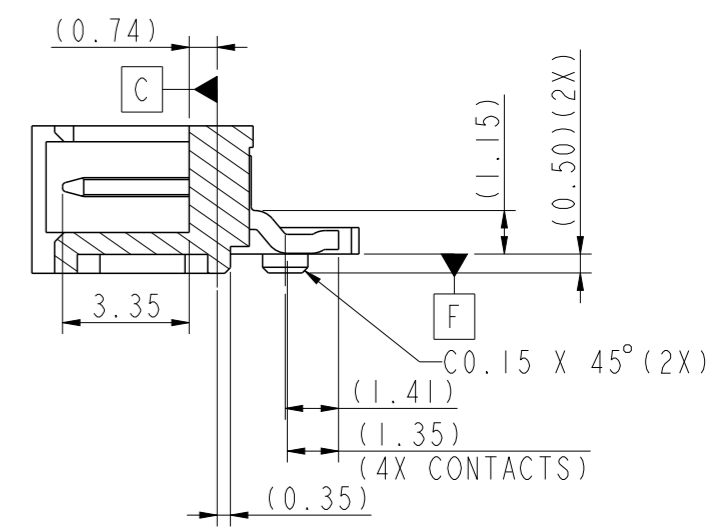

SECTION C-C
SCALE 5.000

spec ref	dr	Jeffrey Lim	2012/11/01
tolerance std	eng	Jeffrey Lim	2013/10/18
ASME Y14.5	chr	-	-
	appr	Chen-Hong Tan	2013/10/18

TOLERANCES UNLESS OTHERWISE SPECIFIED

surface	linear	0.X	±0.45
		0.XX	±0.25
		0.XXX	±-
	angular	0°	±3°

projection	MM
size	A3
scale	3.000
ecn no	ELX-S-16065-1
rel level	Released
product family	-
title	2.5" LOW PROFILE SATA PLUG
cat. no.	-

dwg no	10120214	rev	B
Product - Customer Drw		sheet 1 of 3	



Copyright FCI.

PRODUCT NO.
SEE TABLE

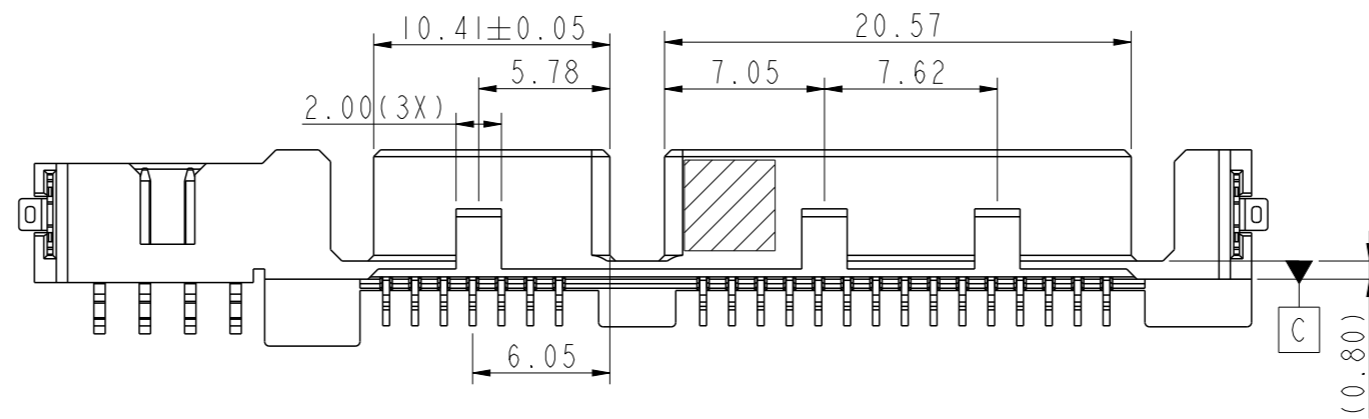
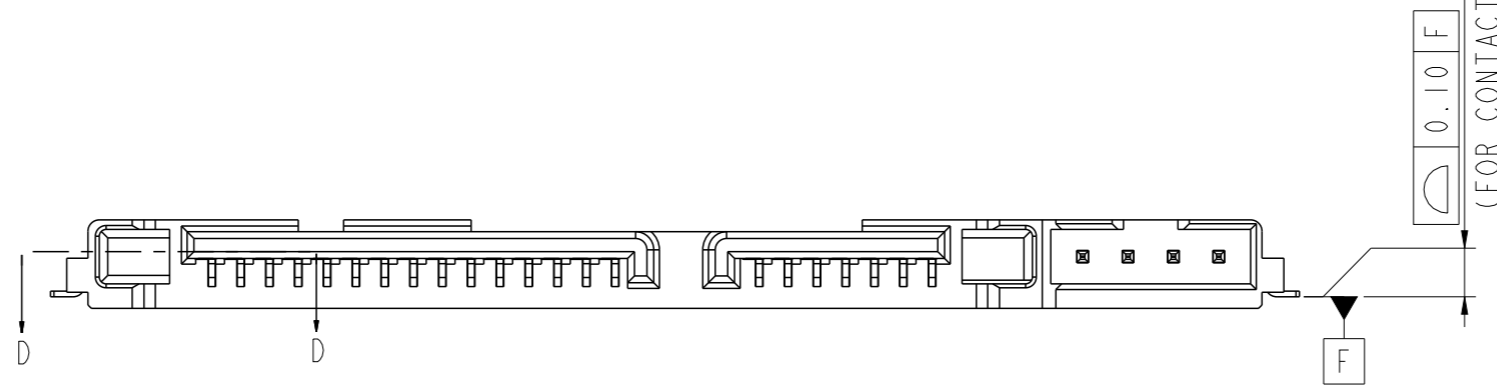
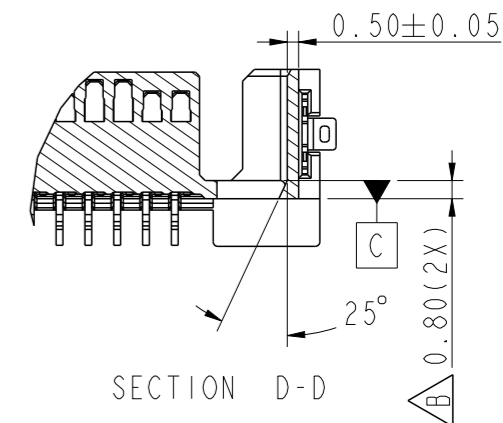
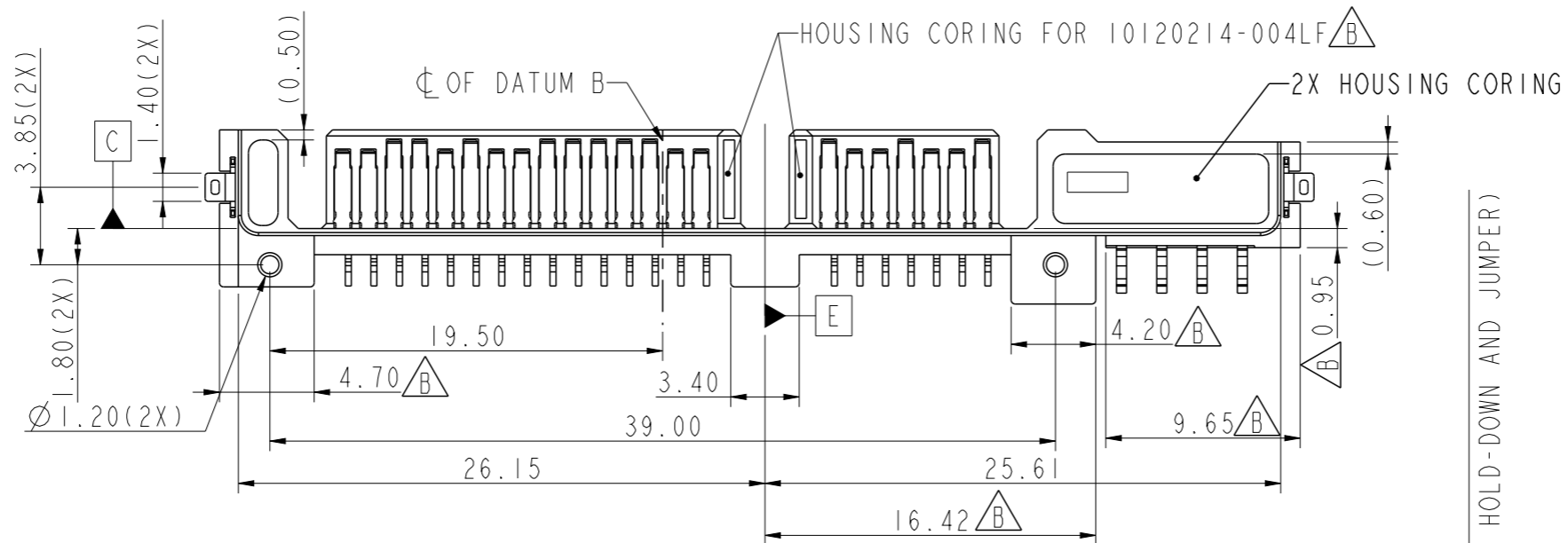

spec ref	dr	Jeffrey Lim	2012/11/01	projection	MM	size	A3	scale	3.000
tolerance std	eng	Jeffrey Lim	2013/10/18			ecn no	ELX-S-16065-1		
TOLERANCES UNLESS OTHERWISE SPECIFIED	chr	-	-			product family	-	rel level	Released
	appr	Chen-Hong Tan	2013/10/18		title 2.5" LOW PROFILE SATA PLUG	dwg no 10120214	rev B	www.fci.com	
	surface	linear	0.X					\pm 0.45	cat. no.
	angular	0°	\pm 3°						

PRODUCT NO.	PACKAGING	REMARK
10120214-002LF	NA	OBSOLETE
10120214-003LF	TRAY	
10120214-004LF		

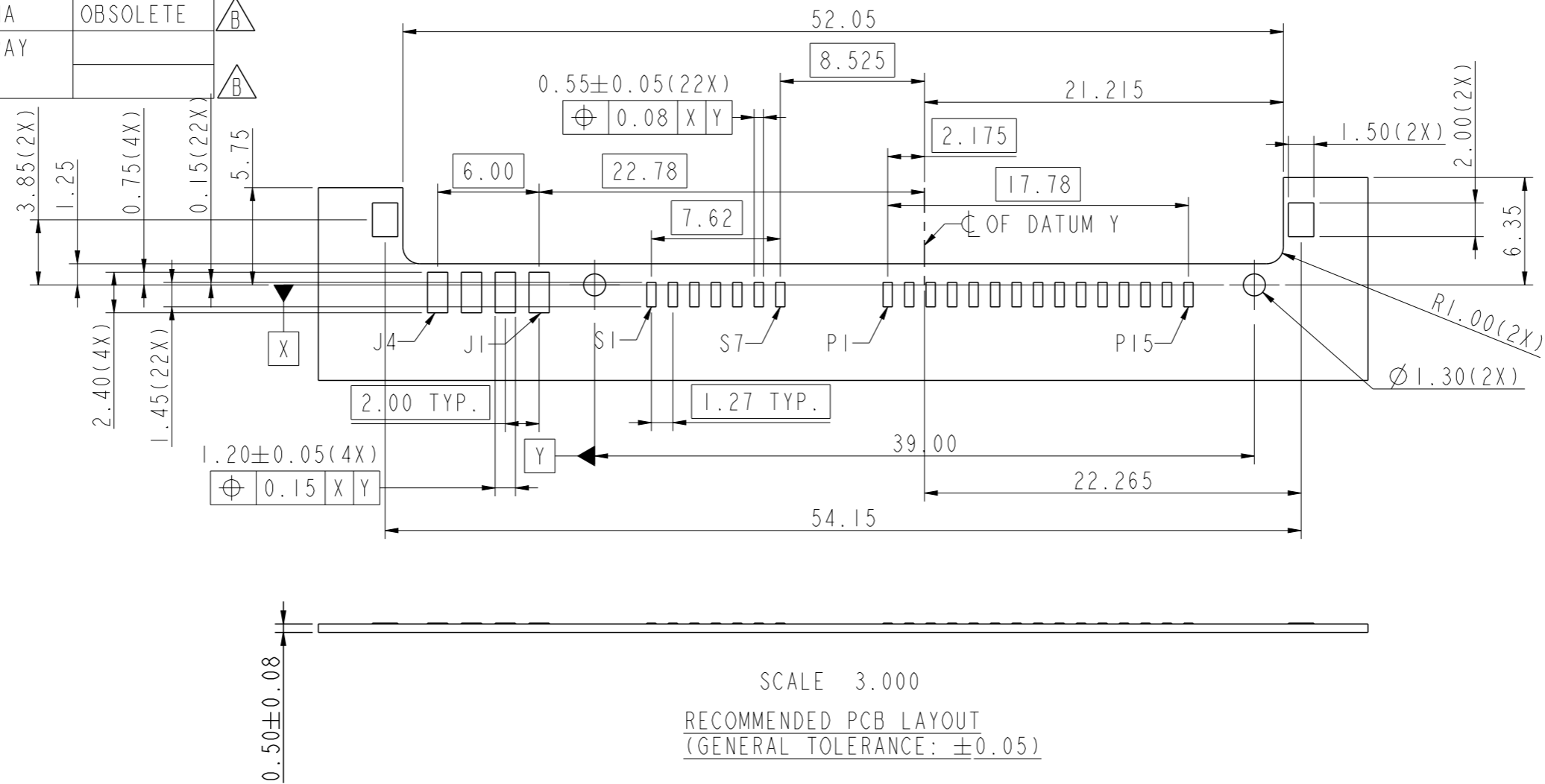

SCALE 3.000
 RECOMMENDED PCB LAYOUT
 (GENERAL TOLERANCE: ±0.05)

- NOTES:
- HOUSING: HIGH TEMPERATURE THERMOPLASTIC, BLACK, UL94V-0, REGRIND 20% MAX.
 CONTACT, JUMPER & HOLD DOWN: COPPER ALLOY
 - FINISH:
 CONTACT: 1.27um MIN. Ni UNDERPLATE OVERALL, 0.38um MIN. Au ON CONTACT AREA,
 1.91um MIN. 100% MATTE Sn(LEAD-FREE) ON SOLDER TAILS
 JUMPER: 1.27um MIN. Ni UNDERPLATE OVERALL, 0.38um MIN. Au ON CONTACT AREA,
 1.91um MIN. 100% MATTE Sn(LEAD-FREE) ON SOLDER TAILS
 HOLD DOWN: 1.91um MIN. 100% MATTE Sn(LEAD-FREE) OVER 1.27um MIN. Ni UNDERPLATE
 - FLAT AREA FREE FROM BURR AND FLASHES FOR VACUUM PICK-UP
 - PRODUCT SPECIFICATION: GS-12-194
 - PACKAGING SPECIFICATION: GS-14-952
 - THIS PRODUCT MEETS EUROPEAN UNION DIRECTIVES AND OTHER COUNTRY REGULATIONS AS DESCRIBED IN GS-47-0004
 - THE HOUSING WILL WITHSTAND EXPOSURE TO 260°C PEAK TEMPERATURE FOR 10 SECONDS IN A CONVECTION, INFRA-RED OR VAPOR PHASE REFLOW OVEN
 - A SYMBOL $\triangle B$ WILL BE NEXT TO ANY DIMENSION, VIEW OR NOTE WHICH HAS BEEN MODIFIED WITH THE CURRENT DRAWING REVISION



Copyright FCI.

spec ref	dr	Jeffrey Lim	2012/11/01	projection	MM	size	A3	scale	3.000	
tolerance std	eng	Jeffrey Lim	2013/10/18			ecn no	ELX-S-16065-1			
TOLERANCES UNLESS OTHERWISE SPECIFIED surface \checkmark	chr	-	-			product family	-	rel level	Released	
	appr	Chen-Hong Tan	2013/10/18			title	2.5" LOW PROFILE SATA PLUG		rev	B
	linear	0.X	±0.45	www.fci.com	cat. no.	-	Product - Customer Drw	sheet 3 of 3		
		0.XX	±0.25			dwg no	10120214			
		0.XXX	±-							
	angular	0°	±3°							