

Ratings

Voltage: 150 V
Temperature: -40~70°C

Conductor

Conductor count: 8
Gauge: 18 AWG 0.82 mm²
Material: tinned copper strands
Strand size: $\varnothing 0.127 \times 65$
Resistance at 20 °C: 23.2 Ω /km Max

Insulator

Material: HDPE
Color: red, black, white, yellow, blue, green, orange, purple
Diameter: $\varnothing 1.65 \pm 0.10$ mm
Nominal thickness: 0.21 mm
Resistance at 20 °C: 100 M Ω /km Min

Wrap

Material: cotton paper

Filler

Material: aramid fiber

Outer jacket

Material: TPU
Color: white
Diameter: $\varnothing 7.3 \pm 0.30$ mm
Nominal thickness: 0.7 mm

Tests

Tensile strength: 26 kgf min
Dielectric test: 1500 V dc for 1 minute without breakdown
Bend test at 200 g, $\pm 60^\circ$, 30 cycles /min: 15,000 cycle minimum

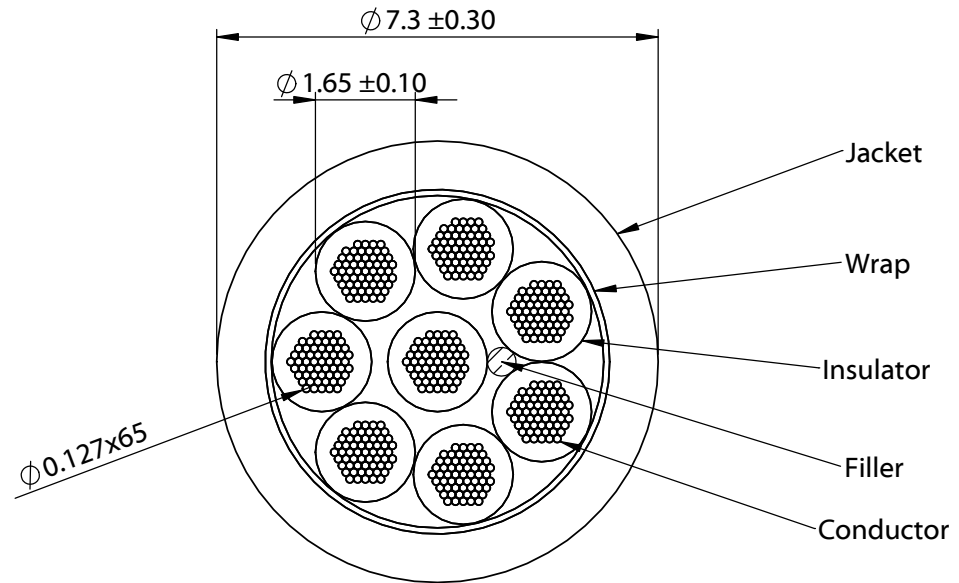
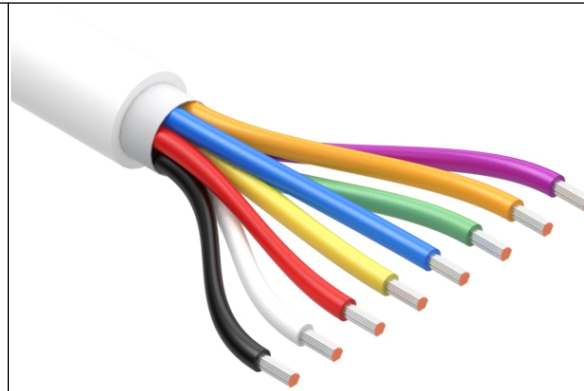

Revision:	Date:	Description:
A	9/12/2022	Initial release

Prepared: **MP**
Digitally signed by MP
Date: 2022.09.16 08:06:01 -0700

Verified: **PB**
Digitally signed by PB
Date: 2022.09.22 11:52:58 -0700

Dimensions are in millimeters.
Tolerances:
X: ± 0.5 mm
X.X: ± 0.3 mm
X.XX: ± 0.05 mm

Notes:
RoHS compliant
Jacket meets ISO 10993 Biological Compatibility
Phthalate and halogen free
Function test: no open, no short, no intermittent

Description:
Wire, 8C TS, 18 AWG, 150V, 70C, 7.3 mm, TPU, 75A, white, WBL

TENSILITY
tel 1.541.323.3228 800 877.670.7118
fax 1.541.323.4202 web tensility.com

Size: A Part number: 30-02822
Scale: 8:1 Sheet 1 of 1