



EV2659-Q-03A

36V Switching Charger for Battery Pack with 3-Cell to 6-Cell In Series Evaluation Board

DESCRIPTION

The EV2659-Q-03A is an evaluation board for the MP2659, a highly integrated switching charger designed for portable devices with 3-cell to 6-cell series Li-ion or Li-polymer battery packs. It can achieve up to 3A of charge current, and supports a variety of battery chemistry types with different full battery voltages.

The MP2659 can operate under a maximum 36V DC input voltage and absolute maximum voltage up to 45V. When an input power supply is present, the MP2659 charges the battery with three phases: pre-charge, constant current charge, and constant voltage charge.

To guarantee safe operation, the MP2659 has robust protection features, such as battery short-circuit protection (SCP), battery over-voltage protection (OVP), battery temperature sensing and protection, thermal shutdown, and charging safety timer.

ELECTRICAL SPECIFICATIONS

Parameter	Symbol	Value	Units
Input voltage	V_{IN}	15 to 36	V
Battery charge voltage regulation	V_{BATT_REG}	3.6 to 4.35 (Adjustable)	V
Fast charge current	I_{CC}	Up to 3	A

FEATURES

- Up to 36V Operation Input Voltage
- 45V Maximum Sustainable Voltage When Not Switching
- Up to 3A Charge Current
- 3-Cell to 6-Cell In Series with 3.6V, 4.2V, 4.35V, or 4.15V Charge Regulation Voltage for Each Cell
- Supports LiFePO4 Battery
- 0.5% Battery Regulation Voltage Accuracy
- Input Current Limit Regulation
- Minimum Input Voltage Regulation
- Charge Operation Indicator
- Dead Battery Pack Recovery
- Battery Over-Voltage Protection (OVP)
- Safety Timer
- Battery NTC Thermal Monitor

APPLICATIONS

- Industrial Medical Equipment
- Power Tools
- Robot and Portable Vacuum Cleaners
- Wireless Speakers

All MPS parts are lead-free, halogen-free, and adhere to the RoHS directive. For MPS green status, visit the MPS website under Quality Assurance. "MPS", the MPS logo, and "Simple, Easy Solutions" are trademarks of Monolithic Power Systems, Inc. or its subsidiaries.

EV2659-Q-03A EVALUATION BOARD



(LxWxH) 6.1cmx5.1cmx1.3cm

Board Number	MPS IC Number
EV2659-Q-03A	MP2659GQ-0000

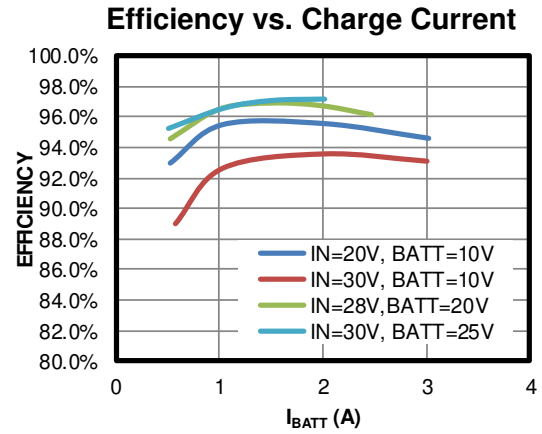

QUICK START GUIDE

This board is designed for the MP2659, a highly integrated switching charger for 3-cell to 6-cell Li-ion/Li-polymer batteries that are connected in series. This board's layout accommodates most commonly used capacitors.

1. Connect the battery pack to the BATT and GND connectors. Ensure that the battery's positive and negative terminals are not reverse-connected.
2. If using a battery emulator, preset the battery emulator to the correct voltage. Turn the emulator off, connect to BATT and GND, then turn the emulator's output on.
3. Preset the input power source to its correct voltage, then turn the power source off. Connect the power source to VIN and GND, then turn the power source on. The EVB should start charging the battery.
4. To modify the charging parameters, configure the EVB using the jumpers (see Table 4 on page 6). Table 1 lists the possible configurations.

Table 1: Adjustable Parameters

Parameter	Value	Units
Charge current	1, 1.5, or 2	A
Input current limit	1, 1.5, or 2	A
Cells	3, 4, 5, or 6	N/A
Battery regulation voltage	3.6, 4.2, 4.35, or 4.15	V
Minimum input voltage limit	14, 18, 24, or 28	V

5. The MP2659 utilizes a dead battery pack recovery function if the battery voltage drops below 1.5V/cell. In this mode, the input current is regulated at I_{SHORT} (typically 60mA) for 20ms, and is suspended for 1.4s.

This board can work safely under the applications where $V_{IN} < 20V$. Table 2 lists recommended components for applications that exceed 20V.

Table 2: Component Selections

Pin	Condition	Recommendations
IN	$\leq 20V$ input	Add a $1\mu F/50V$ ceramic capacitor to the IN pin for adaptor applications. Add a $\geq 47\mu F$ capacitor for solar applications.
	$> 20V$ input	Add a $47\mu F/50V$ electrolytic capacitor to the IN pin. A TVS diode is required if the IN voltage exceeds the pin's maximum voltage rating during the V_{IN} hot-insertion test.
BATT	3-cell or 4-cell	Add a $10\mu F/50V$ ceramic capacitor to the BATT pin.
	5-cell or 6-cell	Add a TVS diode or $\geq 47\mu F$ electrolytic capacitor to the BATT pin.
PMID		Add a $2.2\mu F/50V$ ceramic capacitor (1206 size preferred) to the PMID pin. Add a 2A/40V Schottky diode from IN to PMID. A TVS diode is required if the PMID voltage exceeds the pin's maximum voltage rating during the V_{BATT} hot-insertion test.

EVALUATION BOARD SCHEMATIC

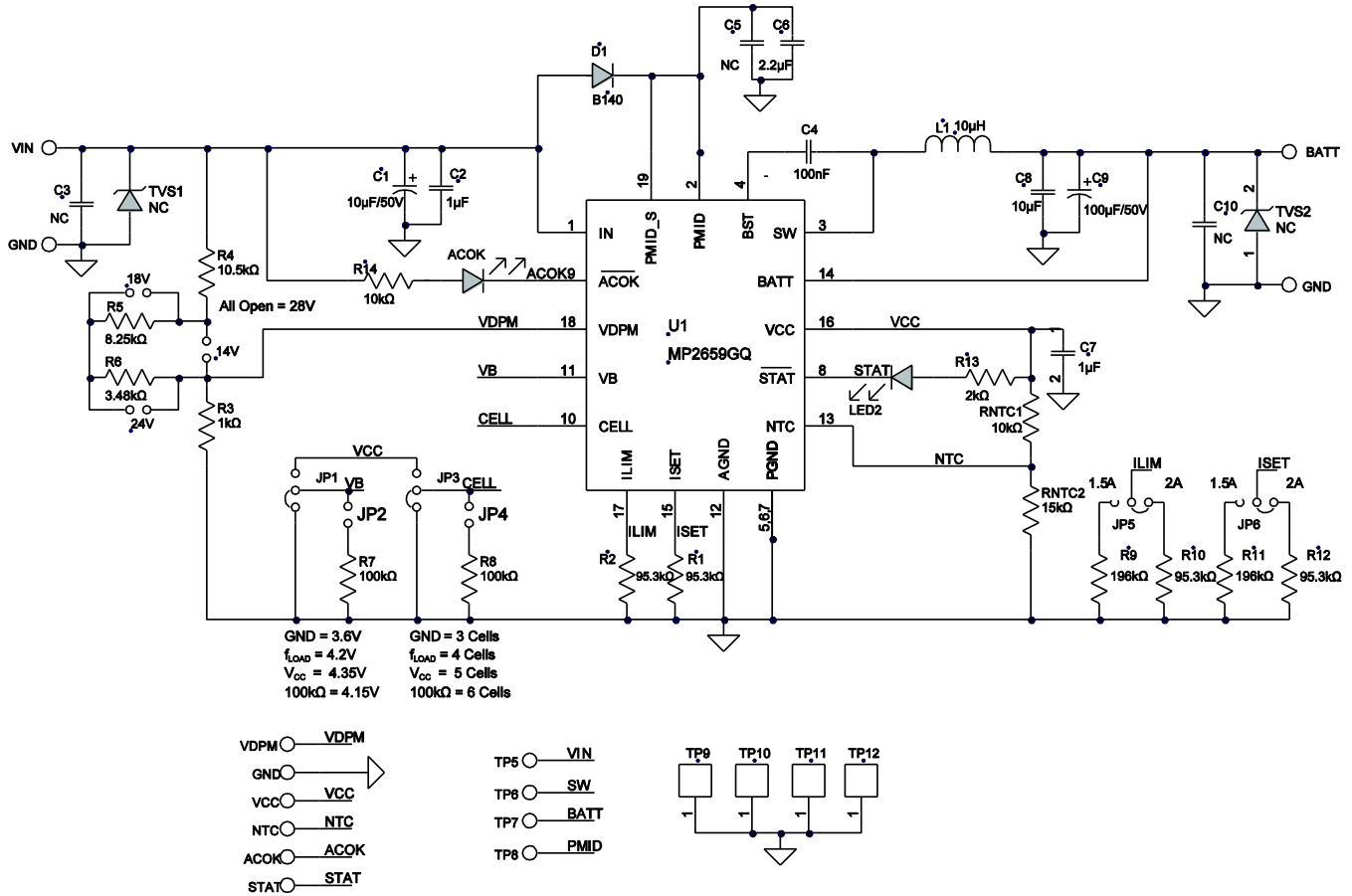

Figure 1: Evaluation Board Schematic (1) (2) (3) (4) (5)

Notes:

- 1) The EV2659-Q-03A can work safely under the applications where $V_{IN} < 20V$.
- 2) For applications exceeding 20V, place a $\geq 47\mu F$ electrolytic capacitor between VIN and GND. Add a Schottky diode with a higher current capacity (e.g. B240A) between VIN and PMID. Use a TVS diode to clamp the VIN voltage if its voltage spike reaches 45V.
- 3) Consider the voltage spike on PMID during battery insertion. Add an extra TVS diode to clamp the PMID voltage if its voltage spike reaches 45V.
- 4) For more component selection information, refer to the MP2659's datasheet.
- 5) The inductor on this evaluation board can only be used in applications where $f_{SW} = 680kHz$ or $I_{CC} < 2.2A$. For applications where $f_{SW} = 350kHz$ or $I_{CC} > 2.2A$, select an inductor with a higher inductance or higher saturation current.

EV2659-Q-03A BILL OF MATERIALS

Qty	Ref	Value	Description	Package	Manufacturer	Manufacturer P/N
1	C1	10 μ F	Electrolytic capacitor, 50V	DIP	Jianghai	CD287-50V10
1	C2	1 μ F	Ceramic capacitor, 50V, X7R	1206	Murata	GRM31MR71H105KA88L
1	C4	100nF	Ceramic capacitor, 50V, X7R	0603	Murata	GRM188R71H104KA93D
1	C6	2.2 μ F	Ceramic capacitor, 50V, X7R	1206	Murata	GRM31CR71H225KA88L
1	C7	1 μ F	Ceramic capacitor, 25V, X7R	0805	Murata	GRM188R71E105KA12D
1	C8	10 μ F	Ceramic capacitor, 50V, X5R	1206	Murata	GRM31CR61H106KA12L
1	C9	100 μ F	Electrolytic capacitor, 50V, 100 μ F	DIP	Rubycon	50YXF100MEFC
1	L1	10 μ H	Inductor, 10 μ H, 35m Ω , 4A	SMD	Würth	744066100
1	ACOK	Red	LED red	0805	Bright LED	F3D02R-4A
1	STAT	Green	LED green	0805	Bright LED	F3D02HG-1A
4	R1, R2, R10, R12	95.3k Ω	Film resistor, 1%	0603	Yageo	RC0603FR-0795K3L
1	RNTC1	10k Ω	Film resistor, 1%	0603	Yageo	RC0603FR-0710KL
1	R3	1k Ω	Film resistor, 1%	0603	Yageo	RC0603FR-071KL
1	R4	10.5k Ω	Film resistor, 1%	0603	Yageo	RC0603FR-0710K5L
1	R5	8.25k Ω	Film resistor, 1%	0603	Yageo	RC0603FR-078K25L
1	R6	3.48k Ω	Film resistor, 1%	0603	Yageo	RC0603FR-073K48L
2	R7, R8	100k Ω	Film resistor, 5%	0603	Yageo	RC0603JR-07100KL
2	R9, R11	196k Ω	Film resistor, 1%	0603	Yageo	RC0603FR-07196KL
1	R13	2k Ω	Film resistor, 1%	0603	Yageo	RC0603FR-072KL
1	R14	10k Ω	Film resistor, 5%	0603	Yageo	RC0603JR-0710K
1	RNTC2	15k Ω	Film resistor, 1%	0603	Yageo	RC0603FR-0715KL
1	D1	B140	Schottky diode	SMA	Diodes	B140
1	U1	MP2659	Switching charger	QFN-19 (3mmx3mm)	MPS	MP2659GQ-0000

CONNECTIONS

Table 3: Connectors

Connectors	Description
TP1/VIN	Connect to the input source's positive terminal.
TP2/GND	Connect to the input source's negative terminal.
TP3/BATT	Connect to the battery pack's positive terminal.
TP4/GND	Connect to the battery pack's negative terminal.
TP5/VIN	Test point for VIN.
TP6/SW	Test point for the switching node.
TP7/BATT	Test point for BATT.
TP8/PMID	Test point for PMID.
TP9, TP10, TP11, TP12	Test point for ground.
VDPM, VCC, NTC, ACOK, STAT	Test connection for related signals.

Table 4: Jumpers and Shunts

Jumpers	Description	Default	All Open
JP1, JP2	Selects the battery regulation voltage for each cell.	4.35V	4.2V
JP3, JP4	Selects the battery cell numbers.	3 cells	4 cells
JP5	Selects the input current limit.	2A	1A
JP6	Selects the constant current charge current.	2A	1A
JP7, JP8, JP9	Selects the minimum input voltage limit.	14V	28V

PCB LAYOUT

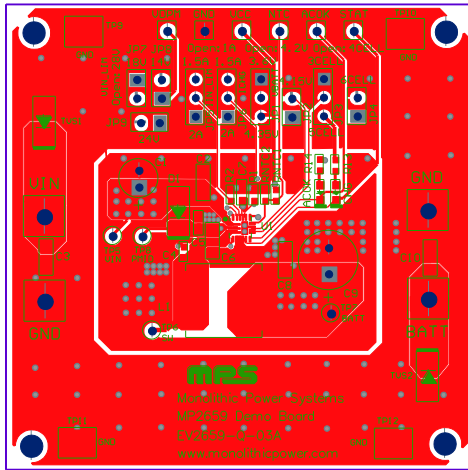

Figure 2: Top Layer

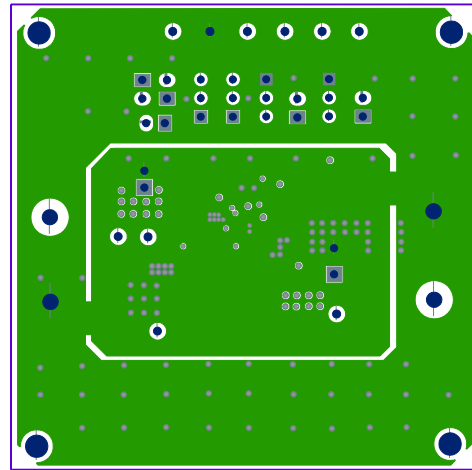

Figure 3: Inner Layer 1

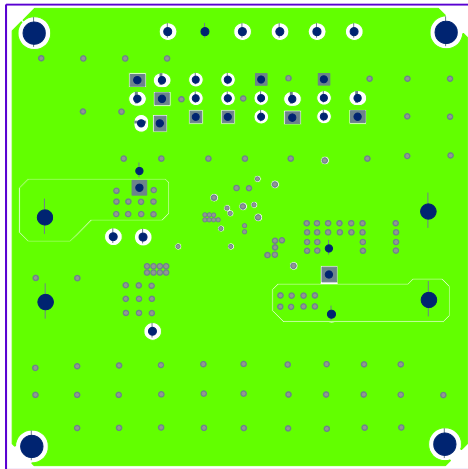

Figure 4: Inner Layer 2

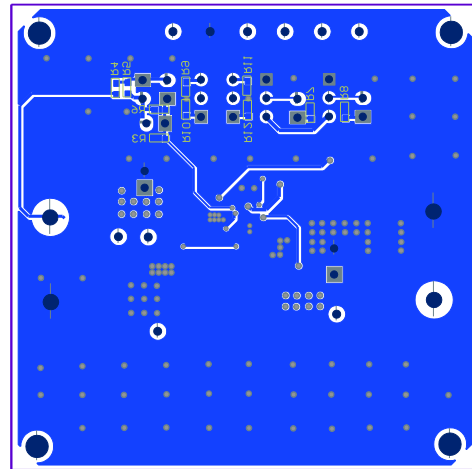

Figure 5: Bottom Layer

Revision History

Revision #	Revision Date	Description	Pages Updated
1.0	12/2/2020	Initial Release	-

Notice: The information in this document is subject to change without notice. Please contact MPS for current specifications. Users should warrant and guarantee that third-party Intellectual Property rights are not infringed upon when integrating MPS products into any application. MPS will not assume any legal responsibility for any said applications.