



FEATURES

- 460W output power
- Exceeds 92% efficiency at 50% load (230Vac Input)
- 12V main output
- 12V standby output of 30W
- 1U height: 3.4" x 7.75" x 1.57"
- 11.1 Watts per cubic inch density
- N+1 redundancy capable, including hot plugging (up to 8 in parallel)
- Droop current sharing on 12V main output, ORing FET
- Overvoltage, overcurrent, overtemperature protection
- Internal cooling fan (variable speed)
- PMBus™ / I²C interface with status indicators
- RoHS compliant
- Two-year warranty

PRODUCT OVERVIEW

The D1U86G-W-460-12-HxxDC is a bulk front end power supply which meets the needs of systems requiring high efficiency distributed power architectures. The output power of this supply is rated at 460W with one main and one standby output. The supply provides high efficiency performance, hot plug capability, and parallel operation with droop current sharing. Closed-loop internal fan cooling provides reliable long life operation. Industry standard PMBus™ communication protocol makes system integration with this supply seamless and straightforward. The low-profile design and dense packaging makes this supply ideal for delivering reliable, efficient power to servers, workstations, storage devices and other distributed power systems.

ORDERING GUIDE

Part Number	Power Output	Main Output	Standby Output	Airflow
* To Be Discontinued D1U86G-W-460-12-HB4DC	460W	12V	12V	Back to front
* To Be Discontinued D1U86G-W-460-12-HB3DC	460W	12V	12V	Front to back

INPUT CHARACTERISTICS

Parameter	Conditions	Min.	Nom.	Max.	Units
Input Voltage Operating Range		90	115/230	264	Vac
Frequency		47	50/60	63	Hz
Turn-on Voltage	Ramp up	81	85	89	Vac
Turn-off Voltage	Ramp down	70.5	74.3	78	
Maximum Input Current (100Vac)	460W			5.5	Arms
Inrush Current	At 264Vac at 25°C cold start			30	Apk
Power Factor	At 230Vac, full load		0.99		
Efficiency (230Vac) excluding fan load	20% load	88			%
	50% load	92			
	100% load	88			

OUTPUT VOLTAGE CHARACTERISTICS

Output Voltage	Parameter	Conditions	Min.	Typ.	Max.	Units
12V	Voltage Set Point	1A load	12.27	12.3	12.33	Vdc
	Static Regulation		11.85		12.45	
	Ripple Voltage & Noise ¹	20MHz Bandwidth			120	mV p-p
	Droop Regulation		0.27	0.3	0.33	V
	Output Current		0		38.3	A
	Load Capacitance				22,000	µF
12VSB	Voltage Set Point		11.97	12.0	12.03	Vdc
	Line and Load Regulation		11.4		12.6	
	Ripple Voltage & Noise ¹	20MHz Bandwidth			120	mV p-p
	Output Current		0		2.5	A
	Load Capacitance				1000	µF

¹ Ripple and noise are measured with 0.1 µF of ceramic capacitance and 10 µF of tantalum capacitance on each of the power supply outputs. A short coaxial cable with 50Ω scope termination is used.



Available now at www.murata-ps.com/en/3d/acdc.html



OUTPUT CHARACTERISTICS					
Parameter	Conditions	Min.	Typ.	Max.	Units
Output Rise Monotonicity	No voltage excursion				
Startup Time	AC ramp up			1.5	s
Transient Response	12V, 50% load step, 0.5A/μs di/dt			300	mV
	12VSB, 50% load step, 0.5A/μs di/dt			600	
Current sharing accuracy (up to 8 in parallel)	At 100% load			±10	%
Hot Swap Transients	All outputs remain in regulation			5	%
Holdup Time		10			ms

ENVIRONMENTAL CHARACTERISTICS					
Parameter	Conditions	Min.	Typ.	Max.	Units
Storage Temperature Range		-40		70	°C
Operating Temperature Range		0		50	
Operating Humidity	Noncondensing	5		90	%
Storage Humidity		5		95	
Altitude (without derating at 40°C)		3000			m
Shock	30G non operating				
Operational Vibration	1G, 10 – 500 Hz, 1.6G (non-operational)				
MTBF	Per Telcordia SR-322 M1C1 @ 40°C	635K			hrs
Safety Approvals (pending)	CSA/UL 60950-1-07-2nd Ed. IEC 60950-1:2005 (2nd Edition) w Am. 1:2009 EN 60950-1:2006 +A11:2009 +A1:2010 CE Marking per LVD DIRECTIVE 2006/95/EC				
Input Fuse	Power Supply has internal 6.3A/250V slow blow fuse on the AC line input				
Weight	1.76 lbs (798g)				

PROTECTION CHARACTERISTICS						
Output Voltage	Parameter	Conditions	Min.	Typ.	Max.	Units
12V	Overtemperature (intake)	Autorestart	57	60	63	°C
	Overvoltage	Latching	13.6		15	V
	Overcurrent	Latching	42		49.8	A
12VSB	Overvoltage	Autorecovery	13.6		15	V
	Overcurrent	Autorecovery	3.5		5.0	A

ISOLATION CHARACTERISTICS					
Parameter	Conditions	Min.	Typ.	Max.	Units
Insulation Safety Rating / Test Voltage	Input to Output - Reinforced	3000			Vrms
	Input to Chassis - Basic	1500			Vrms
Isolation	Main and standby outputs connected directly to chassis				

EMISSIONS AND IMMUNITY		
Characteristic	Standard	Compliance
Input Current Harmonics	IEC/EN 61000-3-2	Complies
Voltage Fluctuation and Flicker	IEC/EN 61000-3-3	Complies
Conducted Emissions	FCC 47 CFR Part 15/CISPR 22/EN55022	Class B, 6dB margin
ESD Immunity	IEC/EN 61000-4-2	Level 3 criteria A
Radiated Field Immunity	IEC/EN 61000-4-3	Level 3 criteria B
Electrical Fast Transient Immunity	IEC/EN 61000-4-4	Level 3 criteria A
Surge Immunity	IEC/EN 61000-4-5	Level 3 criteria A
Radiated Field Conducted Immunity	IEC/EN 61000-4-6	Level 3 criteria A
Magnetic Field Immunity	IEC/EN 61000-4-8	3 A/m criteria B
Voltage dips, interruptions	IEC/EN 61000-4-11	230Vin, 100% load, Phase 0°, Dip 100% Duration 10ms (A) 230Vin, 50% load, Phase 0°, Dip 100% Duration 20ms (VSB:A, V1:A) 230Vin, 100% load, Phase 0°, Dip 100% Duration > 20ms (VSB, V1:B)

STATUS INDICATORS AND CONTROL SIGNALS

Signal	Description	
PSON#	Pulled low to enable main output	
PRESENT#	Present# signal must be pulled high through a resistor to enable the output, either to the PSU 12V bias output as shown in the wiring diagram or to an external system bias output. The external system bias should be between 3.3V (5.1K pullup resistor) and 12V (10K pullup resistor), with pullup resistors sized proportionally for voltages in between. The Present# signal can be used to communicate the number of power supplies in the system (operational or non-operational). The signal is low when power supply is plugged into the system, and is pulled up high when the power supply is unplugged. Present# is a short pin that results in a fast shut down signal to turn off the main output and discharge the output capacitors when the supply is unplugged.	
PS INTERRUPT	Open drain PMBus™ signal	
PS ADDRESS LINES	A0, A1, A2	
IMON SIGNAL	Analog representation of main output current	
PSOK	AC input not OK and DC output not OK	PSOK Low (<0.6V)
	AC input OK and DC output not OK	PSOK Low (<0.6V)
	AC input OK and DC output OK	PSOK High (>0.6V)
	AC input not OK and DC output OK	PSOK Mid-Level (Less than 2.5V, Greater than 2V)
I2C CLOCK	I ² C clock	
I2C DATA	I ² C data	
LED State	Mode	Operating Condition
Off	AC Turn-off	AC Input is below minimum power-supply turn-on specification or the main output is disabled and not delivering power
Green - solid	Power-good	Power supply standby & main outputs are operating within normal parameters and delivering power

OUTPUT CONNECTOR AND SIGNAL SPECIFICATION

DC and Signal Connector: Gold Plated Card Edge Fingers

Power Supply Output Card Edge (Top Side)

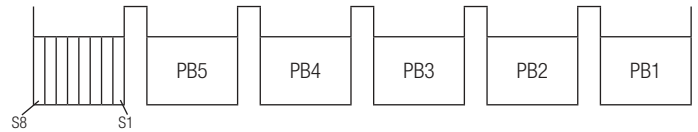

Power Supply Output Card Edge (Bottom Side)

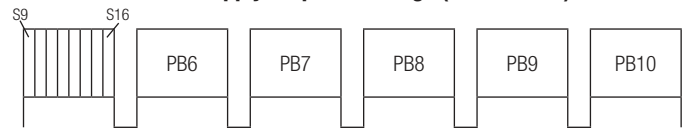

Power Blades	Signal Name
PB1	Vo
PB2	Vo
PB3	Vo
PB4	RTN
PB5	RTN
PB6	RTN
PB7	RTN
PB8	RTN
PB9	Vo
PB10	Vo
Signal Pins	Signal Name
S1	VSB
S2	VSB
S3	Reserved
S4	PS INTERRUPT
S5	PRESENT#
S6	PSOK
S7	IMON
S8	PSON#
S9	SCL
S10	SDA
S11	GND
S12	A0
S13	A1
S14	A2
S15	RTN
S16	RTN

PERFORMANCE DATA

Efficiency

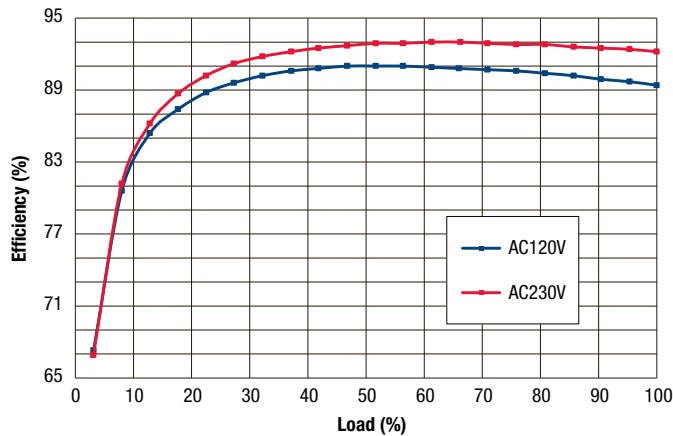

Thermal Derating

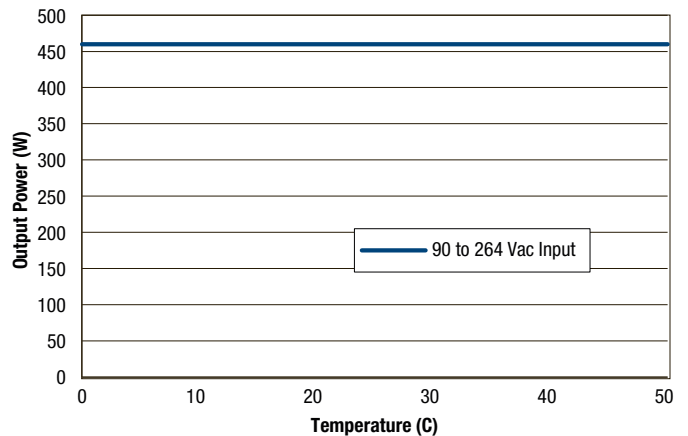

WIRING DIAGRAM FOR OUTPUT

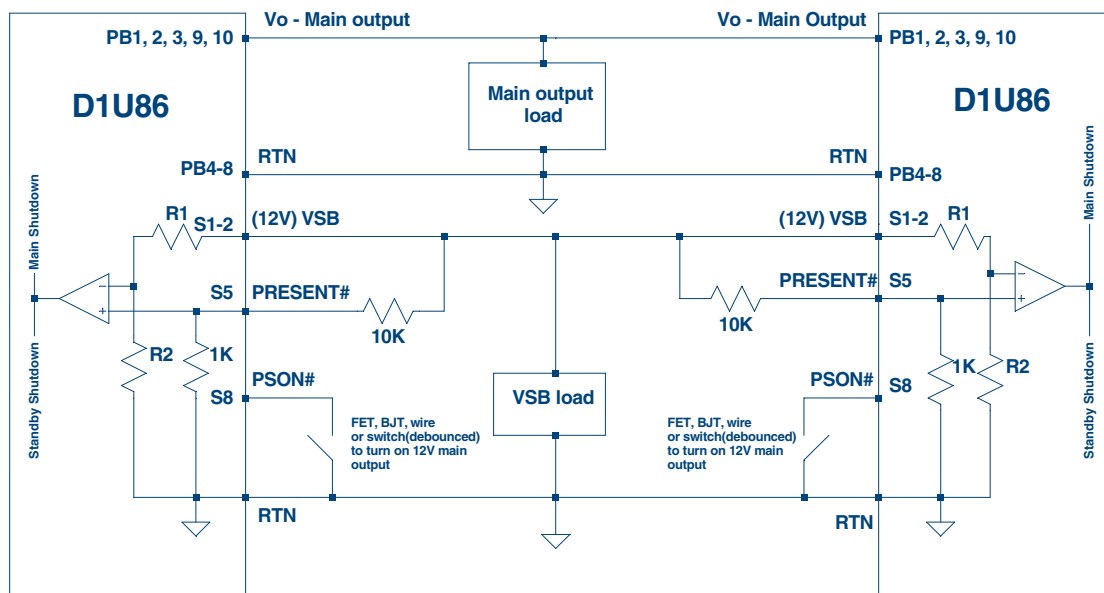

NOTES

Main Output: Current share is achieved using the droop method. Nominal output voltage (12.30V) is achieved at 1A load and output voltage drops at a rate of 7.83mv per amp increase. Startup of parallel power supplies is not internally synchronized. If more than 460W combined power is needed, start-up synchronization must be provided by using a common PS_ON signal. To account for ±10% full load current sharing accuracy and the reduction in full load output voltage due to droop, available output power must be derated by 15% when units are operated in parallel. Internal ORing FETs are provided.

Standby output can be tied together for redundancy but total combined output power must not exceed 30W, Internal MOSFET ORing devices are used.

MECHANICAL DIMENSIONS

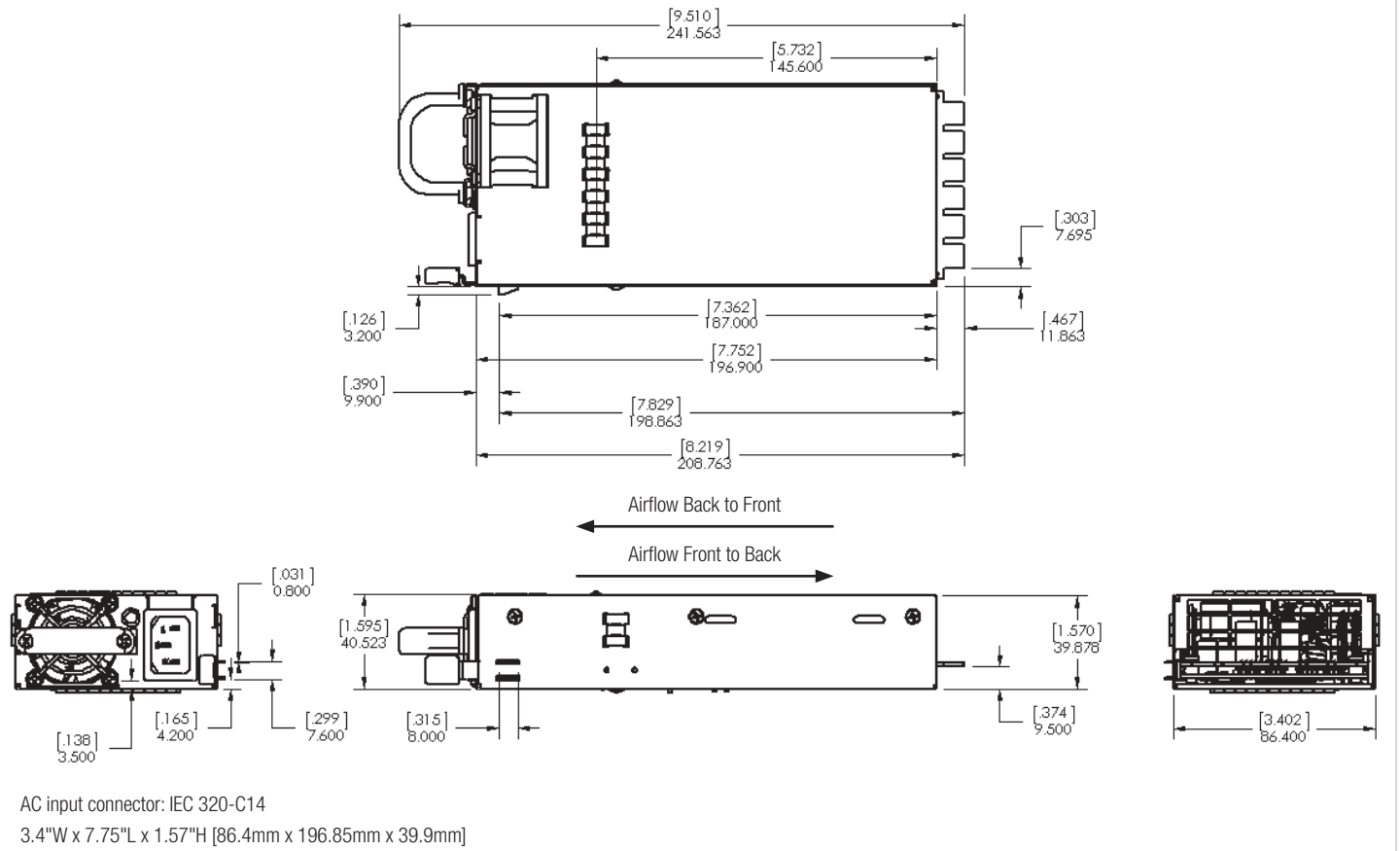

MATING CONNECTOR

Part Number	Description
Molex 45984-1122	Right Angle
FCI 51761-10002406AA	Right Angle

OPTIONAL ACCESSORIES

Description	Part Number
12V D1U86G Output Connector Card	D1U86G-12-CONC

APPLICATION NOTES

Document Number	Description
TBD	D1U86G Output Connector Card
TBD	D1U86G Communication Protocol

Murata Power Solutions, Inc.
129 Flanders Rd. Westborough, Ma 01581, USA.
ISO 9001 and 14001 REGISTERED



This product is subject to the following operating requirements and the Life and Safety Critical Application Sales Policy:
Refer to: <https://www.murata-ps.com/requirements/>

Murata Power Solutions, Inc. makes no representation that the use of its products in the circuits described herein, or the use of other technical information contained herein, will not infringe upon existing or future patent rights. The descriptions contained herein do not imply the granting of licenses to make, use, or sell equipment constructed in accordance therewith. Specifications are subject to change without notice.
© 2021 Murata Power Solutions, Inc.