

**PAL16L8AM, PAL16L8A-2M, PAL16R4AM, PAL16R4A-2M
PAL16R6AM, PAL16R6A-2M, PAL16R8AM, PAL16R8A-2M
STANDARD HIGH-SPEED PAL® CIRCUITS**

SRPS016 – D2705, FEBRUARY 1984 – REVISED MARCH 1992

- **Choice of Operating Speeds**
High-Speed, A Devices . . . 25 MHz Min
Half-Power, A-2 Devices . . . 16 MHz Min
- **Choice of Input/Output Configuration**
- **Package Options Include Both Ceramic DIP and Chip Carrier in Addition to Ceramic Flat Package**

DEVICE	I INPUTS	3-STATE O OUTPUTS	REGISTERED Q OUTPUTS	I/O PORTS
PAL16L8	10	2	0	6
PAL16R4	8	0	4 (3-state buffers)	4
PAL16R6	8	0	6 (3-state buffers)	2
PAL16R8	8	0	8 (3-state buffers)	0

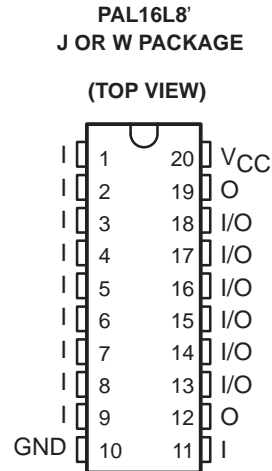

description

These programmable array logic devices feature high speed and a choice of either standard or half-power devices. They combine Advanced Low-Power Schottky technology with proven titanium-tungsten fuses. These devices will provide reliable, high-performance substitutes for conventional TTL logic. Their easy programmability allow for quick design of "custom" functions and typically results in a more compact circuit board. In addition, chip carriers are available for further reduction in board space.

The Half-Power versions offer a choice of operating frequency, switching speeds, and power dissipation. In many cases, these Half-Power devices can result in significant power reduction from an overall system level.

The PAL16' M series is characterized for operation over the full military temperature range of -55°C to 125°C.

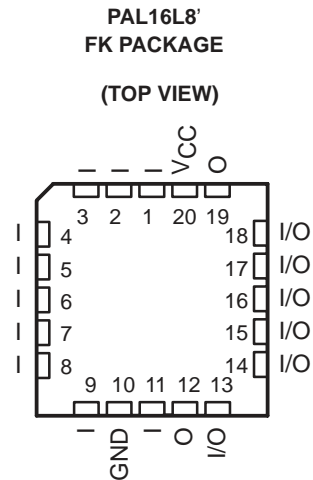

PAL is a registered trademark of Advanced Micro Devices Inc.

PRODUCTION DATA information is current as of publication date. Products conform to specifications per the terms of Texas Instruments standard warranty. Production processing does not necessarily include testing of all parameters.



POST OFFICE BOX 655303 • DALLAS, TEXAS 75265

Copyright © 1992, Texas Instruments Incorporated

PAL16R4AM, PAL16R4A-2M, PAL16R6AM, PAL16R6A-2M, PAL16R8AM, PAL16R8A-2M STANDARD HIGH-SPEED PAL[®] CIRCUITS

SRPS016 – D2705, FEBRUARY 1984 – REVISED MARCH 1992

PAL16R4'
J OR W PACKAGE

(TOP VIEW)

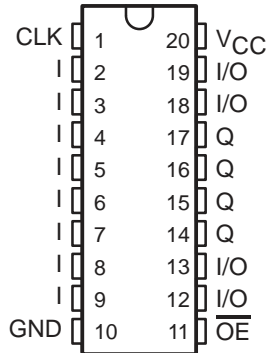

PAL16R4'
FK PACKAGE

(TOP VIEW)

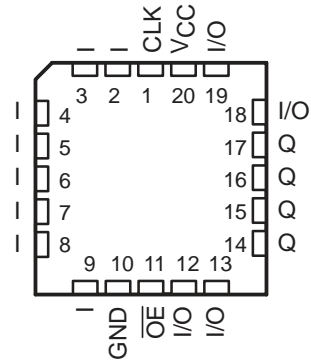

PAL16R6'
J OR W PACKAGE

(TOP VIEW)

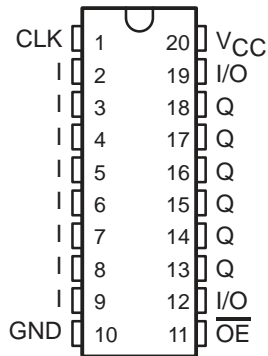

PAL16R6'
FK PACKAGE

(TOP VIEW)

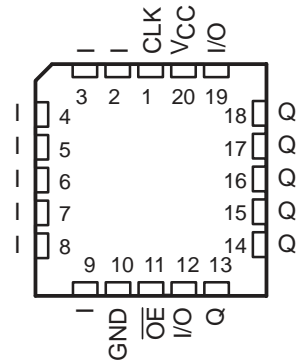

PAL16R8'
J OR W PACKAGE

(TOP VIEW)

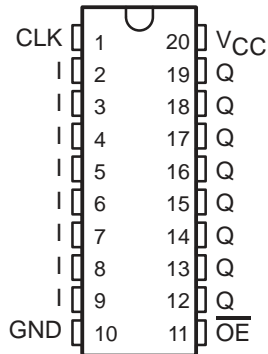

PAL16R8'
FK PACKAGE

(TOP VIEW)

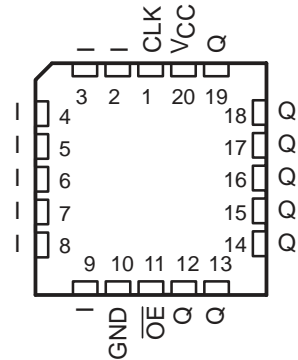

PAL16L8AM, PAL16L8A-2M, PAL16R4AM, PAL16R4A-2M STANDARD HIGH-SPEED PAL[®] CIRCUITS

SRPS016 – D2705, FEBRUARY 1984 – REVISED MARCH 1992

functional block diagrams (positive logic)

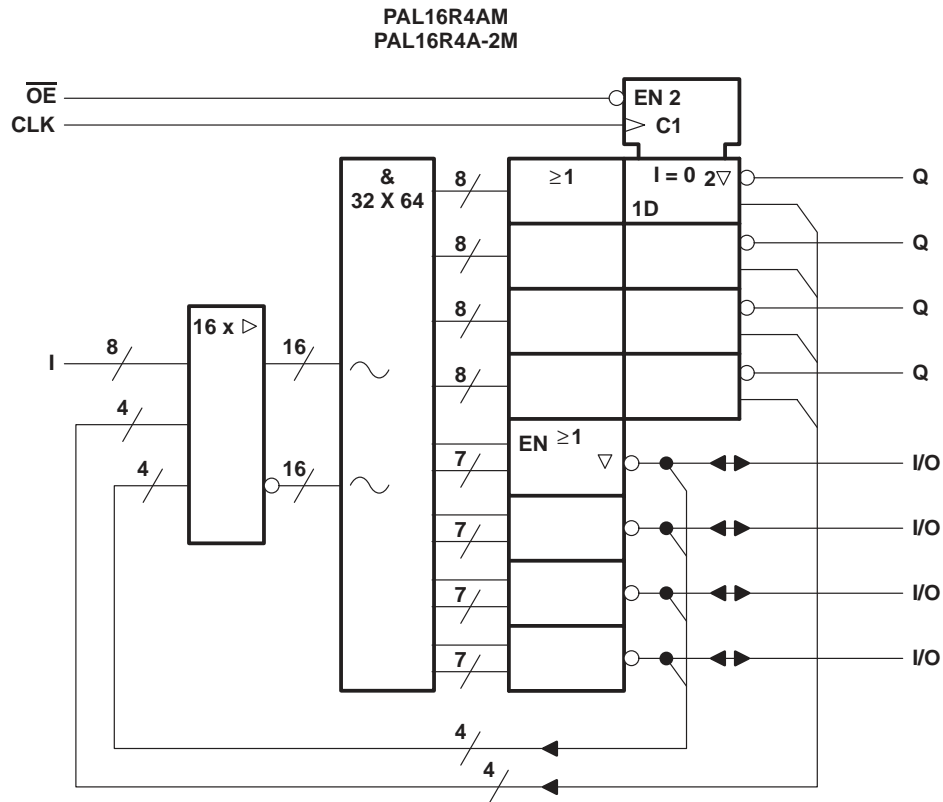
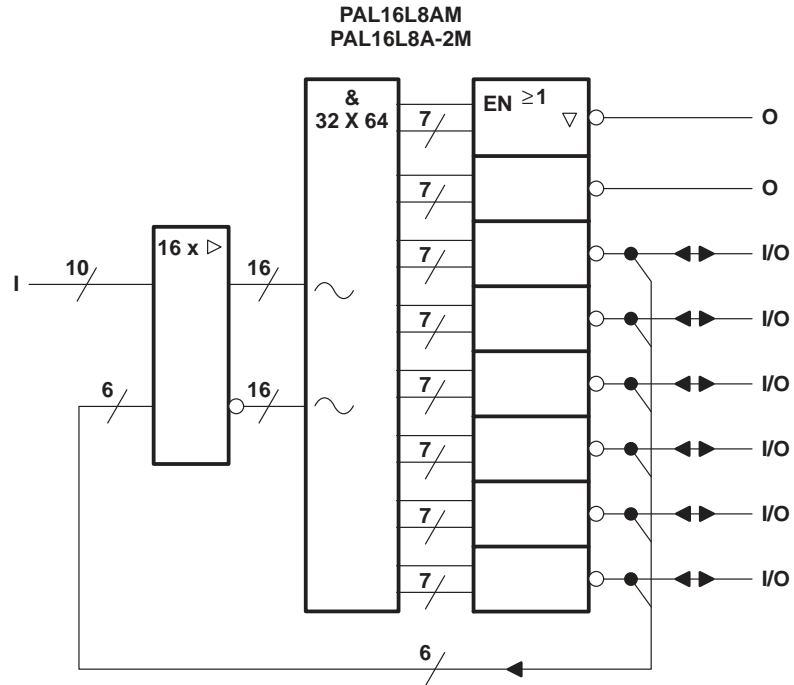

~ denotes fused inputs

PAL16R6AM, PAL16R6A-2M, PAL16R8AM, PAL16R8A-2M STANDARD HIGH-SPEED PAL[®] CIRCUITS

SRPS016 – D2705, FEBRUARY 1984 – REVISED MARCH 1992

functional block diagrams (positive logic)

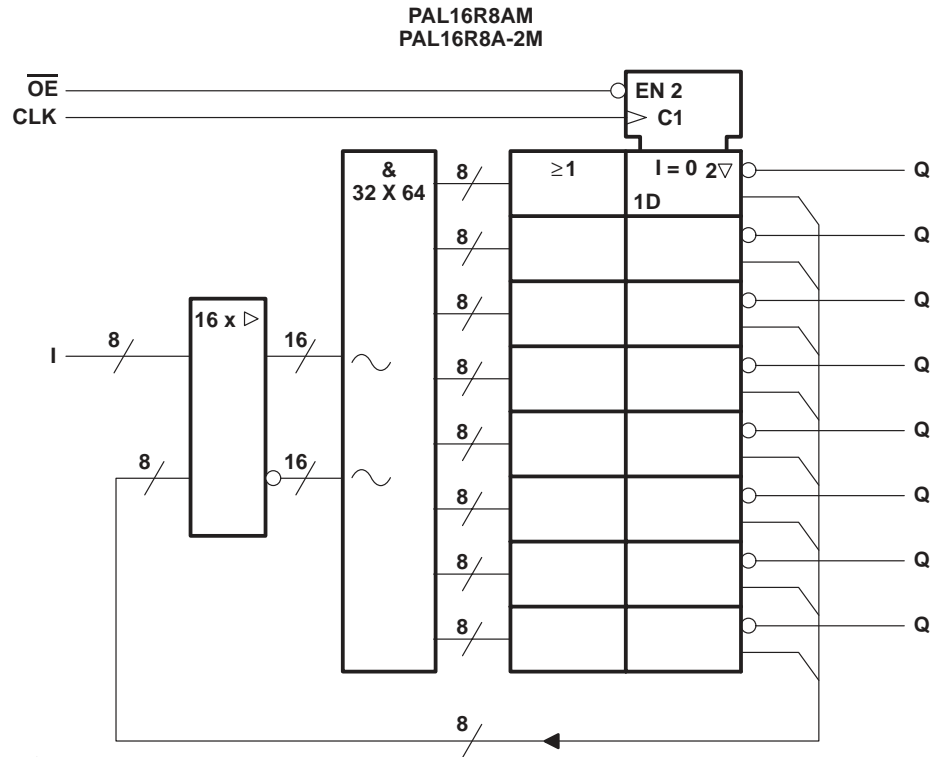
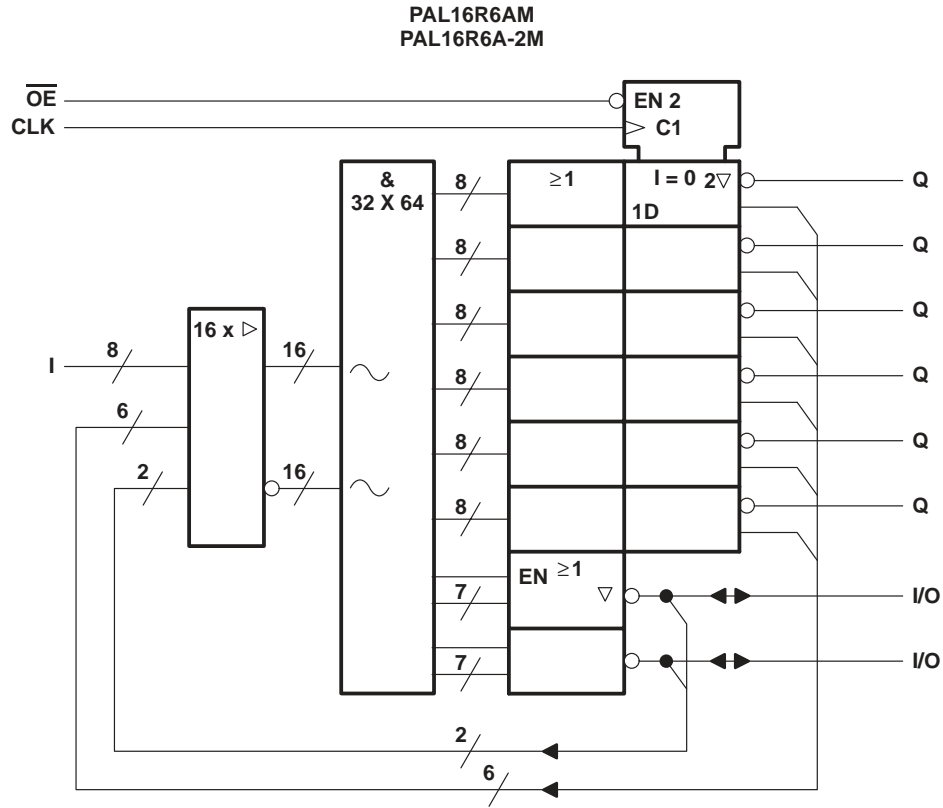

~ denotes fused inputs

**TEXAS
INSTRUMENTS**

POST OFFICE BOX 655303 • DALLAS, TEXAS 75265

logic diagram (positive logic)

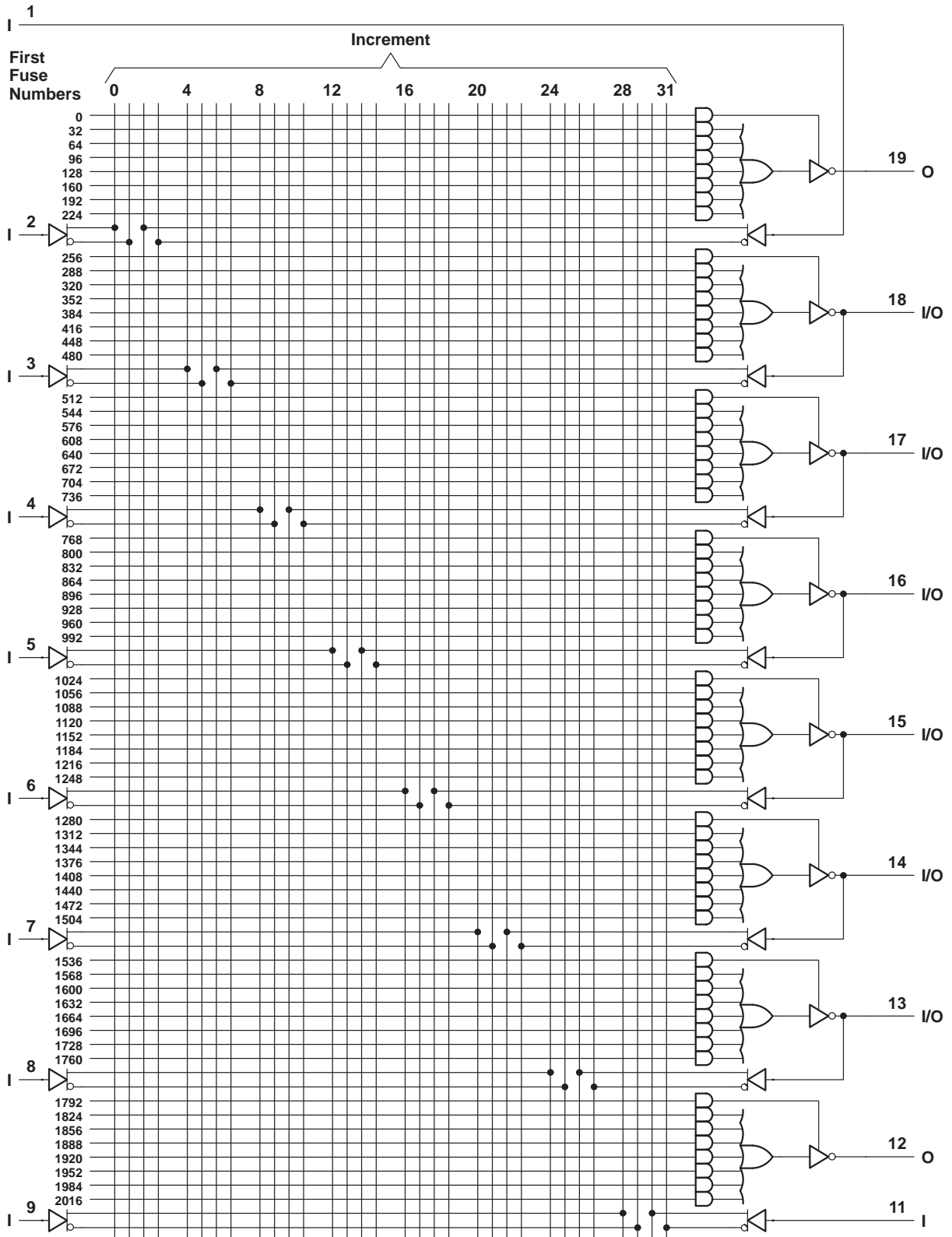

Fuse number = First fuse number + Increment

PAL16R4AM, PAL16R4A-2M STANDARD HIGH-SPEED PAL[®] CIRCUITS

SRPS016 – D2705, FEBRUARY 1984 – REVISED MARCH 1992

logic diagram (positive logic)

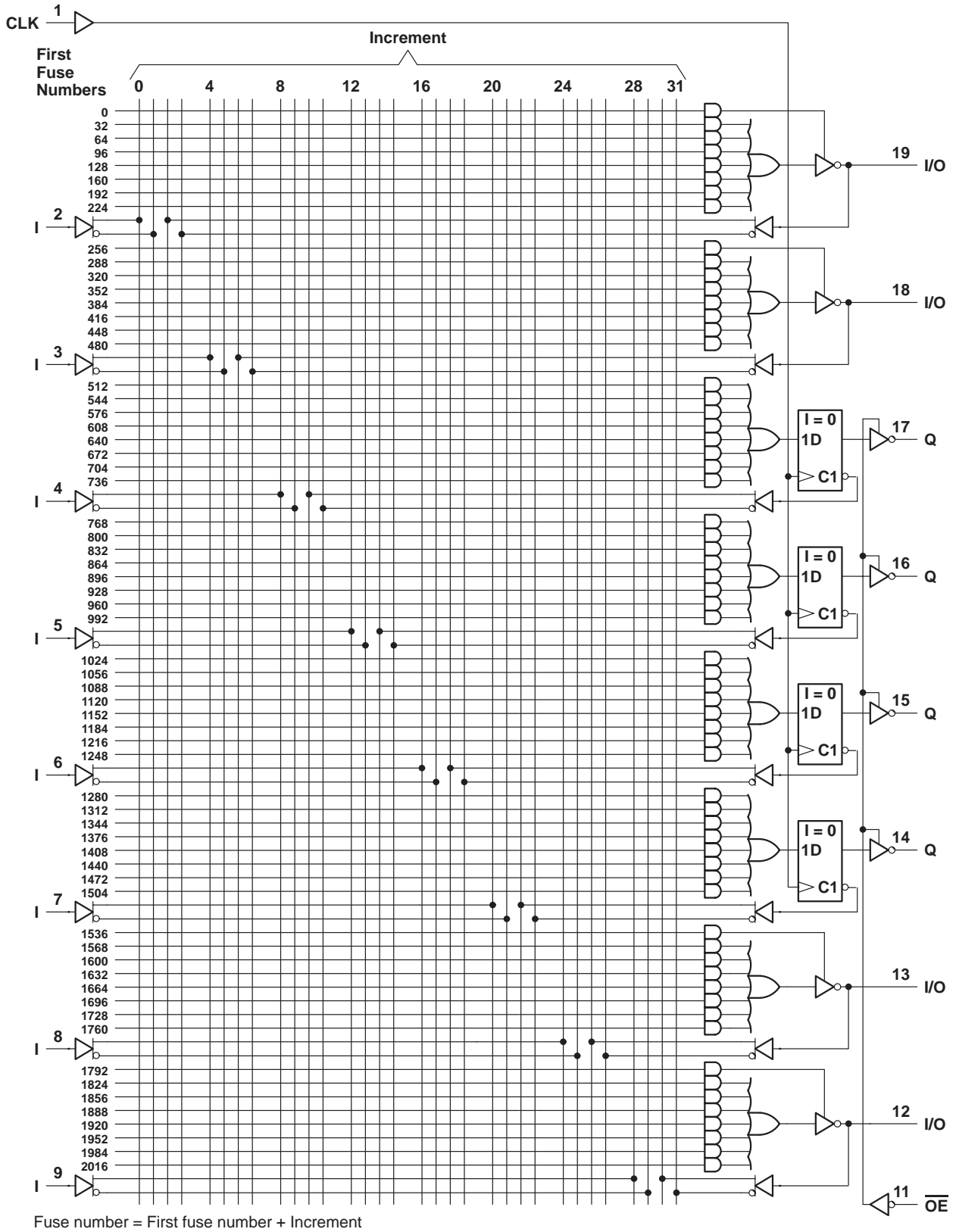

Fuse number = First fuse number + Increment



POST OFFICE BOX 655303 • DALLAS, TEXAS 75265

logic diagram (positive logic)

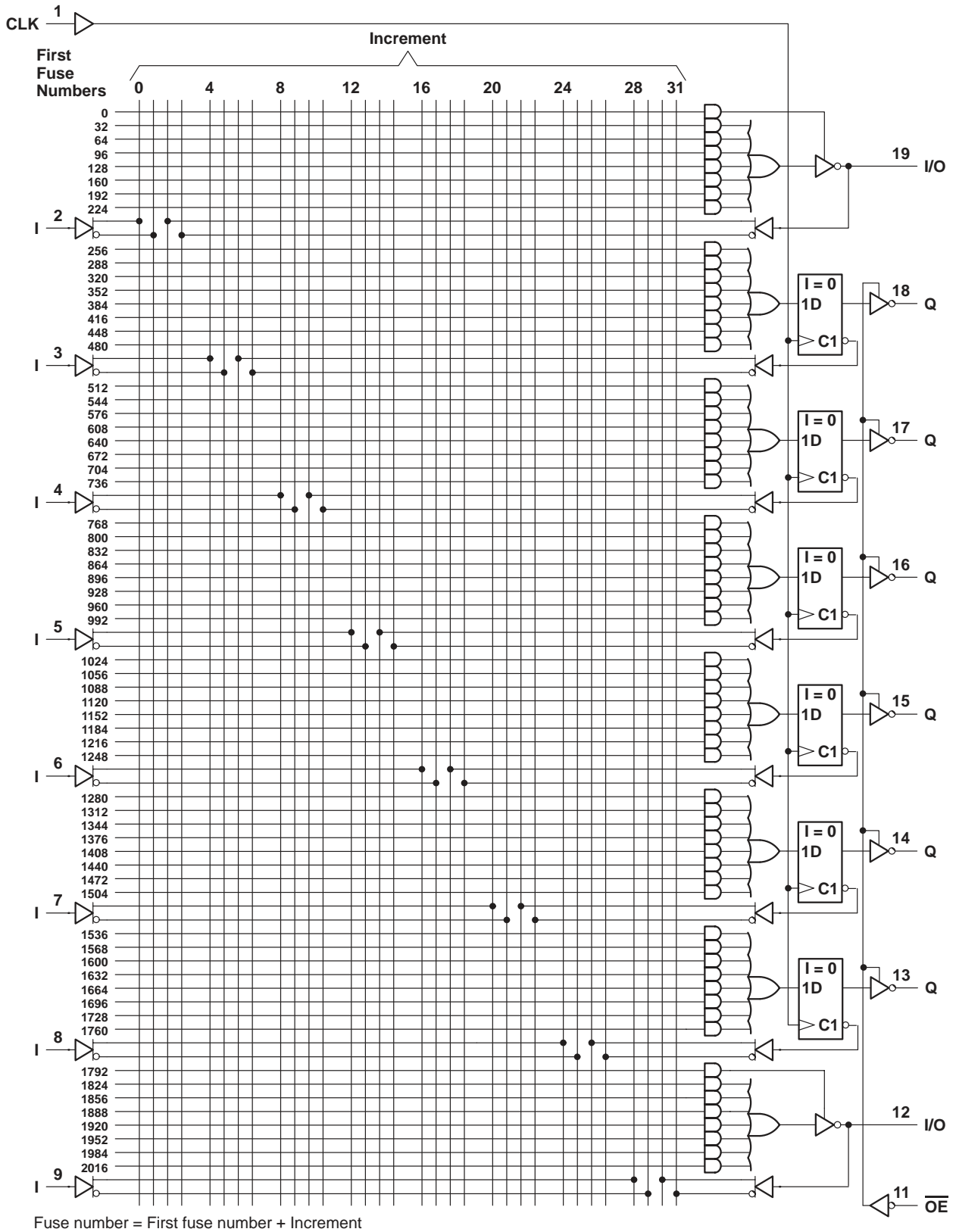

PAL16R8AM, PAL16R8A-2M STANDARD HIGH-SPEED PAL[®] CIRCUITS

SRPS016 – D2705, FEBRUARY 1984 – REVISED MARCH 1992

logic diagram (positive logic)

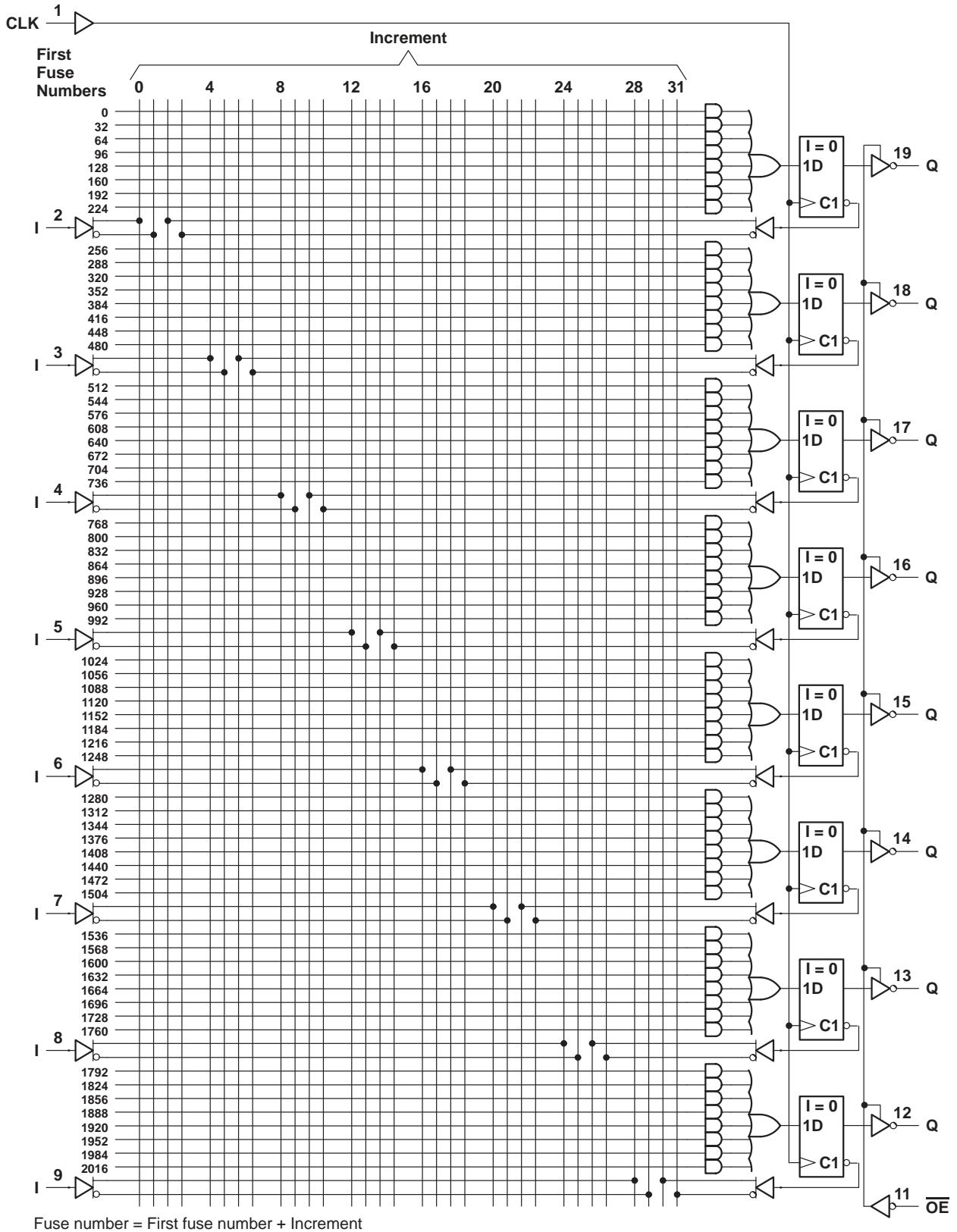

POST OFFICE BOX 655303 • DALLAS, TEXAS 75265

programming information

Texas Instruments programmable logic devices can be programmed using widely available software and inexpensive device programmers.

Complete programming specifications, algorithms, and the latest information on hardware, software, and firmware are available upon request. Information on programmers capable of programming Texas Instruments programmable logic is also available, upon request, from the nearest TI field sales office, local authorized TI distributor, or by calling Texas Instruments at (214) 997-5666.

absolute maximum ratings over operating free-air temperature range (unless otherwise noted)

Supply voltage, V_{CC} (see Note 1)	7 V
Input voltage (see Note 1)	5.5 V
Voltage applied to disabled output (see Note 1)	5.5 V
Operating free-air temperature range	–55°C to 125°C
Storage temperature range	–65°C to 150°C

NOTE 1: These ratings apply except for programming pins during a programming cycle.

recommended operating conditions

		MIN	NOM	MAX	UNIT
V_{CC}	Supply voltage	4.5	5	5.5	V
V_{IH}	High-level input voltage	2		5.5	V
V_{IL}	Low-level input voltage			0.8	V
I_{OH}	High-level output current			–2	mA
I_{OL}	Low-level output current			12	mA
T_A	Operating free-air temperature	–55	25	125	°C

PAL16L8AM, PAL16R4AM, PAL16R6AM, PAL16R8AM STANDARD HIGH-SPEED PAL[®] CIRCUITS

SRPS016 – D2705, FEBRUARY 1984 – REVISED MARCH 1992

electrical characteristics over recommended operating free-air temperature range

PARAMETER		TEST CONDITIONS		MIN	TYP [†]	MAX	UNIT
V _{IK}		V _{CC} = 4.5 V,	I _I = -18 mA			-1.5	V
V _{OH}		V _{CC} = 4.5 V,	I _{OH} = -2 mA	2.4	3.2		V
V _{OL}		V _{CC} = 4.5 V,	I _{OL} = 12 mA		0.25	0.4	V
I _{OZH}	Outputs	V _{CC} = 5.5 V,	V _O = 2.7 V			20	μA
	I/O ports					100	
I _{OZL}	Outputs	V _{CC} = 5.5 V,	V _O = 0.4 V			-20	μA
	I/O ports					-100	
I _I		V _{CC} = 5.5 V,	V _I = 5.5 V			0.2	mA
I _{IH}	I/O Ports	V _{CC} = 5.5 V,	V _I = 2.7 V			100	μA
	All others					25	
I _{IL}	$\overline{\text{OE}}$ input	V _{CC} = 5.5 V,	V _I = 0.4 V			-0.2	mA
	All others					-0.1	
I _{OS} [‡]		V _{CC} = 5.5 V,	V _O = 0.5 V	-30		-250	mA
I _{CC}		V _{CC} = 5.5 V,	V _I = 0, Outputs open		75	180	mA

timing requirements

		MIN	MAX	UNIT
f _{clock}	Clock Frequency	0	25	MHz
t _w	Pulse duration (see Note 2)	Clock high	15	ns
		Clock low	20	
t _{su}	Setup time, input or feedback before CLK [↑]	25		ns
t _h	Hold time, input or feedback after CLK [↑]	0		ns

NOTE 2: The total clock period of clock high and clock low must not exceed clock frequency, f_{clock}. The minimum pulse durations specified are only for clock high or low, but not for both simultaneously.

switching characteristics over recommended ranges of supply voltage and operating free-air temperature (unless otherwise noted)

PARAMETER	FROM (INPUT)	TO (OUTPUT)	TEST CONDITION	MIN	TYP [†]	MAX	UNIT	
f _{max}			R1 = 390 Ω, R2 = 750 Ω, See Figure 1	25	45		MHz	
t _{pd}	I, I/O	O, I/O				15	30	ns
t _{pd}	CLK [↑]	Q			10	20		ns
t _{en}	$\overline{\text{OE}}$ ↓	Q			15	25		ns
t _{dis}	$\overline{\text{OE}}$ ↑	Q			10	25		ns
t _{en}	I, I/O	O, I/O			14	30		ns
t _{dis}	I, I/O	O, I/O			13	30		ns

[†] All typical values are at V_{CC} = 5 V, T_A = 25°C.

[‡] Not more than one output should be shorted at a time and the duration of the short circuit should not exceed one second. Set V_O at 0.5 V to avoid test equipment degradation.



PAL16L8A-2M, PAL16R4A-2M, PAL16R6A-2M, PAL16R8A-2M STANDARD HIGH-SPEED PAL[®] CIRCUITS

SRPS016 – D2705, FEBRUARY 1984 – REVISED MARCH 1992

electrical characteristics over recommended operating free-air temperature range

PARAMETER		TEST CONDITIONS		MIN	TYP [†]	MAX	UNIT
V _{IK}		V _{CC} = 4.5 V,	I _I = -18 mA			-1.5	V
V _{OH}		V _{CC} = 4.5 V,	I _{OH} = -2 mA	2.4	3.2		V
V _{OL}		V _{CC} = 4.5 V,	I _{OL} = 12 mA		0.25	0.4	V
I _{OZH}	Outputs	V _{CC} = 5.5 V,	V _O = 2.7 V			20	μA
	I/O ports					100	
I _{OZL}	Outputs	V _{CC} = 5.5 V,	V _O = 0.4 V			-20	μA
	I/O ports					-100	
I _I		V _{CC} = 5.5 V,	V _I = 5.5 V			0.2	mA
I _{IH}	I/O Ports	V _{CC} = 5.5 V,	V _I = 2.7 V			100	μA
	All others					25	
I _{IL}	$\overline{\text{OE}}$ input	V _{CC} = 5.5 V,	V _I = 0.4 V			-0.2	mA
	All others					-0.1	
I _{OS} [‡]		V _{CC} = 5.5 V,	V _O = 0.5 V	-30		-250	mA
I _{CC}		V _{CC} = 5.5 V,	V _I = 0, Outputs open		75	90	mA

timing requirements

			MIN	MAX	UNIT
f _{clock}	Clock Frequency		0	16	MHz
t _w	Pulse duration (see Note 2)	Clock high	25		ns
		Clock low	25		
t _{su}	Setup time, input or feedback before CLK [↑]		35		ns
t _h	Hold time, input or feedback after CLK [↑]		0		ns

NOTE 2: The total clock period of clock high and clock low must not exceed clock frequency, f_{clock}. The minimum pulse durations specified are only for clock high or low, but not for both simultaneously.

switching characteristics over recommended ranges of supply voltage and operating free-air temperature (unless otherwise noted)

PARAMETER	FROM (INPUT)	TO (OUTPUT)	TEST CONDITION	MIN	TYP [†]	MAX	UNIT	
f _{max}			R1 = 390 Ω, R2 = 750 Ω, See Figure 1	16	25		MHz	
t _{pd}	I, I/O	O, I/O				25	40	ns
t _{pd}	CLK [↑]	Q			11	25		ns
t _{en}	$\overline{\text{OE}}$ ↓	Q			20	25		ns
t _{dis}	$\overline{\text{OE}}$ ↑	Q			11	25		ns
t _{en}	I, I/O	O, I/O			25	40		ns
t _{dis}	I, I/O	O, I/O			25	35		ns

[†] All typical values are at V_{CC} = 5 V, T_A = 25°C.

[‡] Not more than one output should be shorted at a time and the duration of the short circuit should not exceed one second. Set V_O at 0.5 V to avoid test equipment degradation.

PARAMETER MEASUREMENT INFORMATION

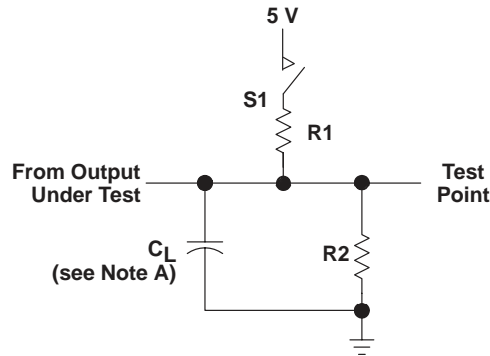

LOAD CIRCUIT FOR 3-STATE OUTPUTS

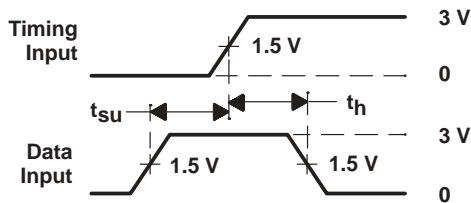

**VOLTAGE WAVEFORMS
 SETUP AND HOLD TIMES**

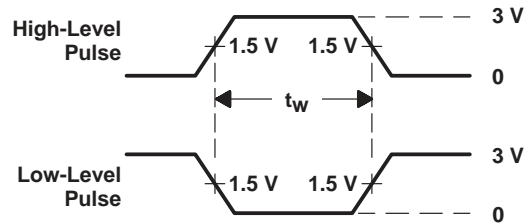

**VOLTAGE WAVEFORMS
 PULSE DURATIONS**

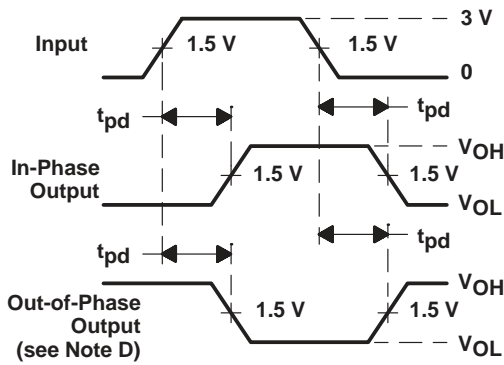

**VOLTAGE WAVEFORMS
 PROPAGATION DELAY TIMES**

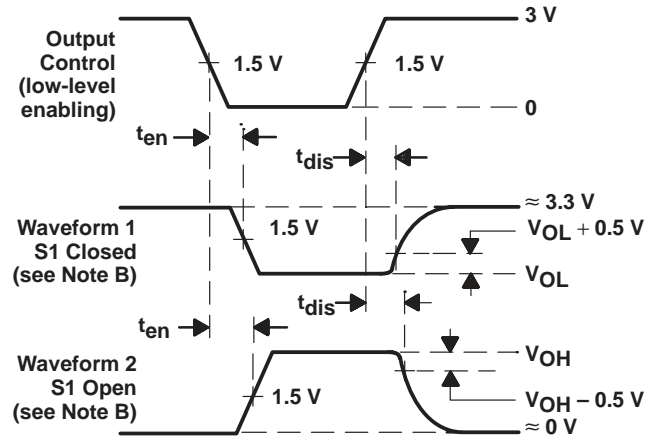

**VOLTAGE WAVEFORMS
 ENABLE AND DISABLE TIMES, 3-STATE OUTPUTS**

- NOTES: A. C_L includes probe and jig capacitance and is 50 pF for t_{pd} and t_{en} , 5 pF for t_{dis} .
 B. Waveform 1 is for an output with internal conditions such that the output is low except when disabled by the output control. Waveform 2 is for an output with internal conditions such that the output is high except when disabled by the output control.
 C. All input pulses have the following characteristics: $PRR \leq 10$ MHz, t_r and $t_f \leq 2$ ns, duty cycle = 50%
 D. When measuring propagation delay times of 3-state outputs, switch S1 is closed.
 E. Equivalent loads may be used for testing.

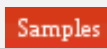

Figure 1. Load Circuit and Voltage Waveforms

PACKAGING INFORMATION

Orderable Device	Status (1)	Package Type	Package Drawing	Pins	Package Qty	Eco Plan (2)	Lead/Ball Finish (6)	MSL Peak Temp (3)	Op Temp (°C)	Device Marking (4/5)	Samples
81036072A	ACTIVE	LCCC	FK	20	1	TBD	POST-PLATE	N / A for Pkg Type	-55 to 125	81036072A PAL16L8A MFKB	Samples
8103607RA	ACTIVE	CDIP	J	20	1	TBD	A42	N / A for Pkg Type	-55 to 125	8103607RA PAL16L8AMJB	Samples
8103607SA	ACTIVE	CFP	W	20	1	TBD	A42	N / A for Pkg Type	-55 to 125	8103607SA PAL16L8AMWB	Samples
81036082A	ACTIVE	LCCC	FK	20	1	TBD	POST-PLATE	N / A for Pkg Type	-55 to 125	81036082A PAL16R8A MFKB	Samples
8103608RA	ACTIVE	CDIP	J	20	1	TBD	A42	N / A for Pkg Type	-55 to 125	8103608RA PAL16R8AMJB	Samples
8103608SA	NRND	CFP	W	20	1	TBD	A42	N / A for Pkg Type	-55 to 125	8103608SA PAL16R8AMWB	
81036092A	ACTIVE	LCCC	FK	20	1	TBD	POST-PLATE	N / A for Pkg Type	-55 to 125	81036092A PAL16R6A MFKB	Samples
8103609RA	ACTIVE	CDIP	J	20	1	TBD	A42	N / A for Pkg Type	-55 to 125	8103609RA PAL16R6AMJB	Samples
8103609SA	NRND	CFP	W	20	1	TBD	A42	N / A for Pkg Type	-55 to 125	8103609SA PAL16R6AMWB	
81036102A	ACTIVE	LCCC	FK	20	1	TBD	POST-PLATE	N / A for Pkg Type	-55 to 125	81036102A PAL16R4A MFKB	Samples
8103610RA	ACTIVE	CDIP	J	20	1	TBD	A42	N / A for Pkg Type	-55 to 125	8103610RA PAL16R4AMJB	Samples
8103610SA	ACTIVE	CFP	W	20	1	TBD	A42	N / A for Pkg Type	-55 to 125	8103610SA PAL16R4AMWB	Samples
81036112A	ACTIVE	LCCC	FK	20	1	TBD	POST-PLATE	N / A for Pkg Type	-55 to 125	81036112A PAL16L8A- 2MFKB	Samples
8103611RA	ACTIVE	CDIP	J	20	1	TBD	A42	N / A for Pkg Type	-55 to 125	8103611RA PAL16L8A-2MJB	Samples
8103611SA	NRND	CFP	W	20	1	TBD	A42	N / A for Pkg Type	-55 to 125	8103611SA PAL16L8A-2MWB	

Orderable Device	Status (1)	Package Type	Package Drawing	Pins	Package Qty	Eco Plan (2)	Lead/Ball Finish (6)	MSL Peak Temp (3)	Op Temp (°C)	Device Marking (4/5)	Samples
81036122A	OBSOLETE	LCCC	FK	20		TBD	Call TI	Call TI	-55 to 125		
8103612RA	OBSOLETE	CDIP	J	20		TBD	Call TI	Call TI	-55 to 125		
8103612SA	OBSOLETE	CFP	W	20		TBD	Call TI	Call TI	-55 to 125		
81036132A	OBSOLETE	LCCC	FK	20		TBD	Call TI	Call TI	-55 to 125		
8103613RA	OBSOLETE	CDIP	J	20		TBD	Call TI	Call TI	-55 to 125		
8103613SA	OBSOLETE	CFP	W	20		TBD	Call TI	Call TI	-55 to 125		
81036142A	ACTIVE	LCCC	FK	20	1	TBD	POST-PLATE	N / A for Pkg Type	-55 to 125	81036142A PAL16R4A- 2MFKB	Samples
8103614RA	OBSOLETE	CDIP	J	20		TBD	Call TI	Call TI	-55 to 125		
8103614SA	NRND	CFP	W	20	1	TBD	A42	N / A for Pkg Type	-55 to 125	8103614SA PAL16R4A-2MWB	
PAL16L8A-2MFKB	ACTIVE	LCCC	FK	20	1	TBD	POST-PLATE	N / A for Pkg Type	-55 to 125	81036112A PAL16L8A- 2MFKB	Samples
PAL16L8A-2MJ	ACTIVE	CDIP	J	20	1	TBD	A42	N / A for Pkg Type	-55 to 125	PAL16L8A-2MJ	Samples
PAL16L8A-2MJB	ACTIVE	CDIP	J	20	1	TBD	A42	N / A for Pkg Type	-55 to 125	8103611RA PAL16L8A-2MJB	Samples
PAL16L8A-2MWB	NRND	CFP	W	20	1	TBD	A42	N / A for Pkg Type	-55 to 125	8103611SA PAL16L8A-2MWB	
PAL16L8AMFKB	ACTIVE	LCCC	FK	20	1	TBD	POST-PLATE	N / A for Pkg Type	-55 to 125	81036072A PAL16L8A MFKB	Samples
PAL16L8AMJ	ACTIVE	CDIP	J	20	1	TBD	A42	N / A for Pkg Type	-55 to 125	PAL16L8AMJ	Samples
PAL16L8AMJB	ACTIVE	CDIP	J	20	1	TBD	A42	N / A for Pkg Type	-55 to 125	8103607RA PAL16L8AMJB	Samples
PAL16L8AMWB	ACTIVE	CFP	W	20	1	TBD	A42	N / A for Pkg Type	-55 to 125	8103607SA PAL16L8AMWB	Samples
PAL16R4A-2MFKB	ACTIVE	LCCC	FK	20	1	TBD	POST-PLATE	N / A for Pkg Type	-55 to 125	81036142A PAL16R4A- 2MFKB	Samples
PAL16R4A-2MJ	NRND	CDIP	J	20	1	TBD	A42	N / A for Pkg Type	-55 to 125	PAL16R4A-2MJ	
PAL16R4A-2MJB	OBSOLETE	CDIP	J	20		TBD	Call TI	Call TI	-55 to 125	8103614RA PAL16R4A-2MJB	

Orderable Device	Status (1)	Package Type	Package Drawing	Pins	Package Qty	Eco Plan (2)	Lead/Ball Finish (6)	MSL Peak Temp (3)	Op Temp (°C)	Device Marking (4/5)	Samples
PAL16R4A-2MWB	NRND	CFP	W	20	1	TBD	A42	N / A for Pkg Type	-55 to 125	8103614SA PAL16R4A-2MWB	
PAL16R4AMFKB	ACTIVE	LCCC	FK	20	1	TBD	POST-PLATE	N / A for Pkg Type	-55 to 125	81036102A PAL16R4A MFKB	Samples
PAL16R4AMJ	ACTIVE	CDIP	J	20	1	TBD	A42	N / A for Pkg Type	-55 to 125	PAL16R4AMJ	Samples
PAL16R4AMJB	ACTIVE	CDIP	J	20	1	TBD	A42	N / A for Pkg Type	-55 to 125	8103610RA PAL16R4AMJB	Samples
PAL16R4AMWB	ACTIVE	CFP	W	20	1	TBD	A42	N / A for Pkg Type	-55 to 125	8103610SA PAL16R4AMWB	Samples
PAL16R6A-2MFKB	OBSOLETE	LCCC	FK	20		TBD	Call TI	Call TI	-55 to 125	81036132A PAL16R6A- 2MFKB	
PAL16R6A-2MJ	OBSOLETE	CDIP	J	20		TBD	Call TI	Call TI	-55 to 125	PAL16R6A-2MJ	
PAL16R6A-2MJB	OBSOLETE	CDIP	J	20		TBD	Call TI	Call TI	-55 to 125	8103613RA PAL16R6A-2MJB	
PAL16R6A-2MWB	OBSOLETE	CFP	W	20		TBD	Call TI	Call TI	-55 to 125	8103613SA PAL16R6A-2MWB	
PAL16R6AMFKB	ACTIVE	LCCC	FK	20	1	TBD	POST-PLATE	N / A for Pkg Type	-55 to 125	81036092A PAL16R6A MFKB	Samples
PAL16R6AMJ	ACTIVE	CDIP	J	20	1	TBD	A42	N / A for Pkg Type	-55 to 125	PAL16R6AMJ	Samples
PAL16R6AMJB	ACTIVE	CDIP	J	20	1	TBD	A42	N / A for Pkg Type	-55 to 125	8103609RA PAL16R6AMJB	Samples
PAL16R6AMWB	NRND	CFP	W	20	1	TBD	A42	N / A for Pkg Type	-55 to 125	8103609SA PAL16R6AMWB	
PAL16R8A-2MFKB	OBSOLETE	LCCC	FK	20		TBD	Call TI	Call TI	-55 to 125	81036122A PAL16R8A- 2MFKB	
PAL16R8A-2MJ	OBSOLETE	CDIP	J	20		TBD	Call TI	Call TI	-55 to 125	PAL16R8A-2MJ	
PAL16R8A-2MJB	OBSOLETE	CDIP	J	20		TBD	Call TI	Call TI	-55 to 125	8103612RA PAL16R8A-2MJB	
PAL16R8A-2MWB	OBSOLETE	CFP	W	20		TBD	Call TI	Call TI	-55 to 125	8103612SA PAL16R8A-2MWB	

Orderable Device	Status (1)	Package Type	Package Drawing	Pins	Package Qty	Eco Plan (2)	Lead/Ball Finish (6)	MSL Peak Temp (3)	Op Temp (°C)	Device Marking (4/5)	Samples
PAL16R8AMFKB	ACTIVE	LCCC	FK	20	1	TBD	POST-PLATE	N / A for Pkg Type	-55 to 125	81036082A PAL16R8A MFKB	
PAL16R8AMJ	ACTIVE	CDIP	J	20	1	TBD	A42	N / A for Pkg Type	-55 to 125	PAL16R8AMJ	
PAL16R8AMJB	ACTIVE	CDIP	J	20	1	TBD	A42	N / A for Pkg Type	-55 to 125	8103608RA PAL16R8AMJB	
PAL16R8AMWB	NRND	CFP	W	20	1	TBD	A42	N / A for Pkg Type	-55 to 125	8103608SA PAL16R8AMWB	

(1) The marketing status values are defined as follows:

ACTIVE: Product device recommended for new designs.

LIFEBUY: TI has announced that the device will be discontinued, and a lifetime-buy period is in effect.

NRND: Not recommended for new designs. Device is in production to support existing customers, but TI does not recommend using this part in a new design.

PREVIEW: Device has been announced but is not in production. Samples may or may not be available.

OBSELETE: TI has discontinued the production of the device.

(2) Eco Plan - The planned eco-friendly classification: Pb-Free (RoHS), Pb-Free (RoHS Exempt), or Green (RoHS & no Sb/Br) - please check <http://www.ti.com/productcontent> for the latest availability information and additional product content details.

TBD: The Pb-Free/Green conversion plan has not been defined.

Pb-Free (RoHS): TI's terms "Lead-Free" or "Pb-Free" mean semiconductor products that are compatible with the current RoHS requirements for all 6 substances, including the requirement that lead not exceed 0.1% by weight in homogeneous materials. Where designed to be soldered at high temperatures, TI Pb-Free products are suitable for use in specified lead-free processes.

Pb-Free (RoHS Exempt): This component has a RoHS exemption for either 1) lead-based flip-chip solder bumps used between the die and package, or 2) lead-based die adhesive used between the die and leadframe. The component is otherwise considered Pb-Free (RoHS compatible) as defined above.

Green (RoHS & no Sb/Br): TI defines "Green" to mean Pb-Free (RoHS compatible), and free of Bromine (Br) and Antimony (Sb) based flame retardants (Br or Sb do not exceed 0.1% by weight in homogeneous material)

(3) MSL, Peak Temp. - The Moisture Sensitivity Level rating according to the JEDEC industry standard classifications, and peak solder temperature.

(4) There may be additional marking, which relates to the logo, the lot trace code information, or the environmental category on the device.

(5) Multiple Device Markings will be inside parentheses. Only one Device Marking contained in parentheses and separated by a "~" will appear on a device. If a line is indented then it is a continuation of the previous line and the two combined represent the entire Device Marking for that device.

(6) Lead/Ball Finish - Orderable Devices may have multiple material finish options. Finish options are separated by a vertical ruled line. Lead/Ball Finish values may wrap to two lines if the finish value exceeds the maximum column width.

Important Information and Disclaimer: The information provided on this page represents TI's knowledge and belief as of the date that it is provided. TI bases its knowledge and belief on information provided by third parties, and makes no representation or warranty as to the accuracy of such information. Efforts are underway to better integrate information from third parties. TI has taken and continues to take reasonable steps to provide representative and accurate information but may not have conducted destructive testing or chemical analysis on incoming materials and chemicals. TI and TI suppliers consider certain information to be proprietary, and thus CAS numbers and other limited information may not be available for release.

In no event shall TI's liability arising out of such information exceed the total purchase price of the TI part(s) at issue in this document sold by TI to Customer on an annual basis.

OTHER QUALIFIED VERSIONS OF PAL16L8A-2M, PAL16L8AM, PAL16R4A-2M, PAL16R4AM, PAL16R6A-2M, PAL16R6AM, PAL16R8A-2M, PAL16R8AM :

- Catalog: [PAL16L8A-2](#), [PAL16L8A](#), [PAL16R4A-2](#), [PAL16R4A](#), [PAL16R6A-2](#), [PAL16R6A](#), [PAL16R8A-2](#), [PAL16R8A](#)

NOTE: Qualified Version Definitions:

- Catalog - TI's standard catalog product

J (R-GDIP-T**)

14 LEADS SHOWN

CERAMIC DUAL IN-LINE PACKAGE



DIM \ PINS **	14	16	18	20
A	0.300 (7,62) BSC	0.300 (7,62) BSC	0.300 (7,62) BSC	0.300 (7,62) BSC
B MAX	0.785 (19,94)	.840 (21,34)	0.960 (24,38)	1.060 (26,92)
B MIN	—	—	—	—
C MAX	0.300 (7,62)	0.300 (7,62)	0.310 (7,87)	0.300 (7,62)
C MIN	0.245 (6,22)	0.245 (6,22)	0.220 (5,59)	0.245 (6,22)



4040083/F 03/03

- NOTES:
- A. All linear dimensions are in inches (millimeters).
 - B. This drawing is subject to change without notice.
 - C. This package is hermetically sealed with a ceramic lid using glass frit.
 - D. Index point is provided on cap for terminal identification only on press ceramic glass frit seal only.
 - E. Falls within MIL STD 1835 GDIP1-T14, GDIP1-T16, GDIP1-T18 and GDIP1-T20.

W (R-GDFP-F20)

CERAMIC DUAL FLATPACK

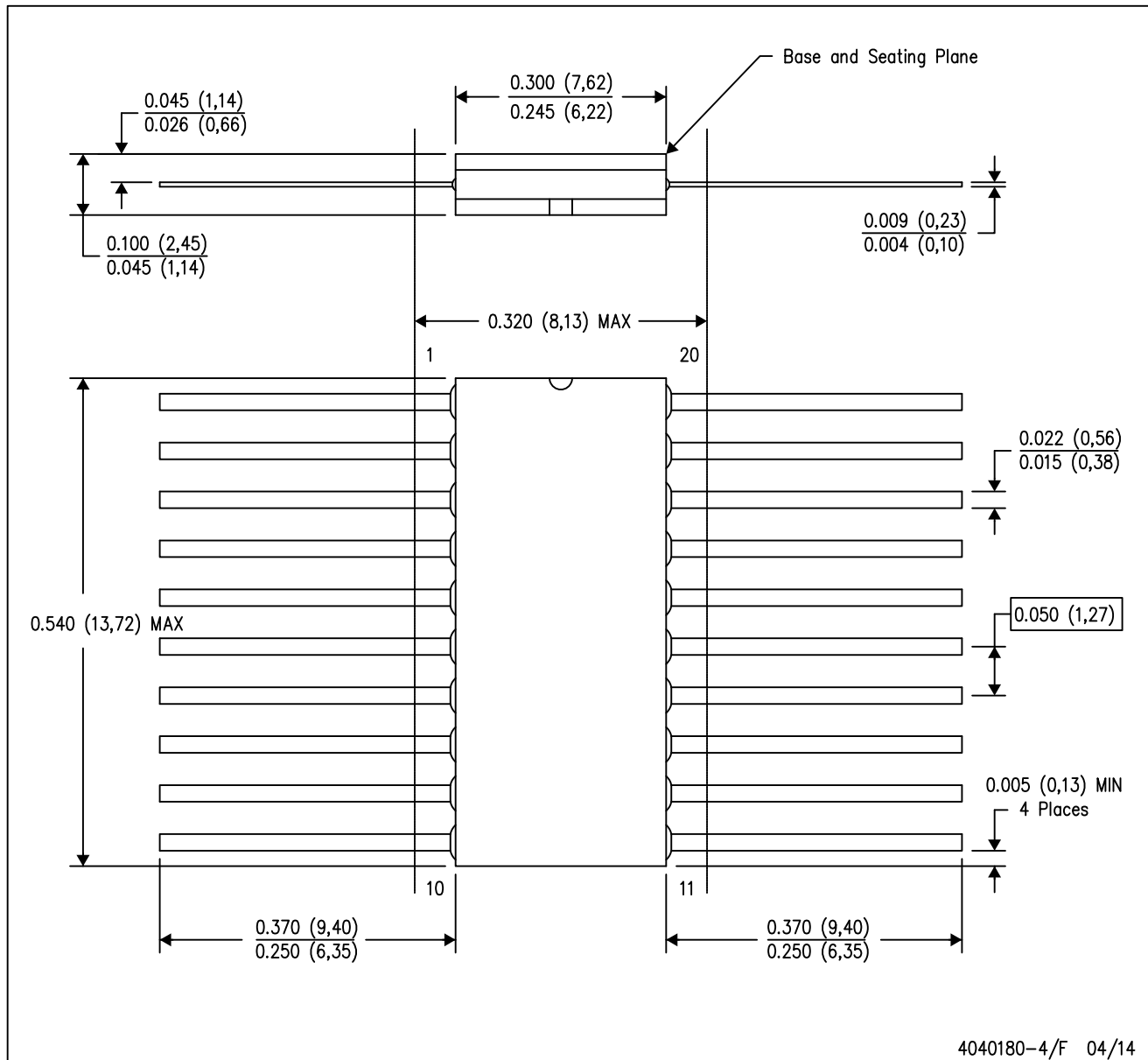

- NOTES:
- A. All linear dimensions are in inches (millimeters).
 - B. This drawing is subject to change without notice.
 - C. This package can be hermetically sealed with a ceramic lid using glass frit.
 - D. Index point is provided on cap for terminal identification only.
 - E. Falls within Mil-Std 1835 GDFP2-F20

FK (S-CQCC-N**)

LEADLESS CERAMIC CHIP CARRIER

28 TERMINAL SHOWN



NO. OF TERMINALS **	A		B	
	MIN	MAX	MIN	MAX
20	0.342 (8,69)	0.358 (9,09)	0.307 (7,80)	0.358 (9,09)
28	0.442 (11,23)	0.458 (11,63)	0.406 (10,31)	0.458 (11,63)
44	0.640 (16,26)	0.660 (16,76)	0.495 (12,58)	0.560 (14,22)
52	0.740 (18,78)	0.761 (19,32)	0.495 (12,58)	0.560 (14,22)
68	0.938 (23,83)	0.962 (24,43)	0.850 (21,6)	0.858 (21,8)
84	1.141 (28,99)	1.165 (29,59)	1.047 (26,6)	1.063 (27,0)



4040140/D 01/11

- NOTES:
- All linear dimensions are in inches (millimeters).
 - This drawing is subject to change without notice.
 - This package can be hermetically sealed with a metal lid.
 - Falls within JEDEC MS-004

IMPORTANT NOTICE

Texas Instruments Incorporated and its subsidiaries (TI) reserve the right to make corrections, enhancements, improvements and other changes to its semiconductor products and services per JESD46, latest issue, and to discontinue any product or service per JESD48, latest issue. Buyers should obtain the latest relevant information before placing orders and should verify that such information is current and complete. All semiconductor products (also referred to herein as "components") are sold subject to TI's terms and conditions of sale supplied at the time of order acknowledgment.

TI warrants performance of its components to the specifications applicable at the time of sale, in accordance with the warranty in TI's terms and conditions of sale of semiconductor products. Testing and other quality control techniques are used to the extent TI deems necessary to support this warranty. Except where mandated by applicable law, testing of all parameters of each component is not necessarily performed.

TI assumes no liability for applications assistance or the design of Buyers' products. Buyers are responsible for their products and applications using TI components. To minimize the risks associated with Buyers' products and applications, Buyers should provide adequate design and operating safeguards.

TI does not warrant or represent that any license, either express or implied, is granted under any patent right, copyright, mask work right, or other intellectual property right relating to any combination, machine, or process in which TI components or services are used. Information published by TI regarding third-party products or services does not constitute a license to use such products or services or a warranty or endorsement thereof. Use of such information may require a license from a third party under the patents or other intellectual property of the third party, or a license from TI under the patents or other intellectual property of TI.

Reproduction of significant portions of TI information in TI data books or data sheets is permissible only if reproduction is without alteration and is accompanied by all associated warranties, conditions, limitations, and notices. TI is not responsible or liable for such altered documentation. Information of third parties may be subject to additional restrictions.

Resale of TI components or services with statements different from or beyond the parameters stated by TI for that component or service voids all express and any implied warranties for the associated TI component or service and is an unfair and deceptive business practice. TI is not responsible or liable for any such statements.

Buyer acknowledges and agrees that it is solely responsible for compliance with all legal, regulatory and safety-related requirements concerning its products, and any use of TI components in its applications, notwithstanding any applications-related information or support that may be provided by TI. Buyer represents and agrees that it has all the necessary expertise to create and implement safeguards which anticipate dangerous consequences of failures, monitor failures and their consequences, lessen the likelihood of failures that might cause harm and take appropriate remedial actions. Buyer will fully indemnify TI and its representatives against any damages arising out of the use of any TI components in safety-critical applications.

In some cases, TI components may be promoted specifically to facilitate safety-related applications. With such components, TI's goal is to help enable customers to design and create their own end-product solutions that meet applicable functional safety standards and requirements. Nonetheless, such components are subject to these terms.

No TI components are authorized for use in FDA Class III (or similar life-critical medical equipment) unless authorized officers of the parties have executed a special agreement specifically governing such use.

Only those TI components which TI has specifically designated as military grade or "enhanced plastic" are designed and intended for use in military/aerospace applications or environments. Buyer acknowledges and agrees that any military or aerospace use of TI components which have **not** been so designated is solely at the Buyer's risk, and that Buyer is solely responsible for compliance with all legal and regulatory requirements in connection with such use.

TI has specifically designated certain components as meeting ISO/TS16949 requirements, mainly for automotive use. In any case of use of non-designated products, TI will not be responsible for any failure to meet ISO/TS16949.

Products

Audio	www.ti.com/audio
Amplifiers	amplifier.ti.com
Data Converters	dataconverter.ti.com
DLP® Products	www.dlp.com
DSP	dsp.ti.com
Clocks and Timers	www.ti.com/clocks
Interface	interface.ti.com
Logic	logic.ti.com
Power Mgmt	power.ti.com
Microcontrollers	microcontroller.ti.com
RFID	www.ti-rfid.com
OMAP Applications Processors	www.ti.com/omap
Wireless Connectivity	www.ti.com/wirelessconnectivity

Applications

Automotive and Transportation	www.ti.com/automotive
Communications and Telecom	www.ti.com/communications
Computers and Peripherals	www.ti.com/computers
Consumer Electronics	www.ti.com/consumer-apps
Energy and Lighting	www.ti.com/energy
Industrial	www.ti.com/industrial
Medical	www.ti.com/medical
Security	www.ti.com/security
Space, Avionics and Defense	www.ti.com/space-avionics-defense
Video and Imaging	www.ti.com/video

TI E2E Community

e2e.ti.com