

PART NUMBER	REV	FIRST USED
680744-1	B	122500-1
680744-2	B	565435-5

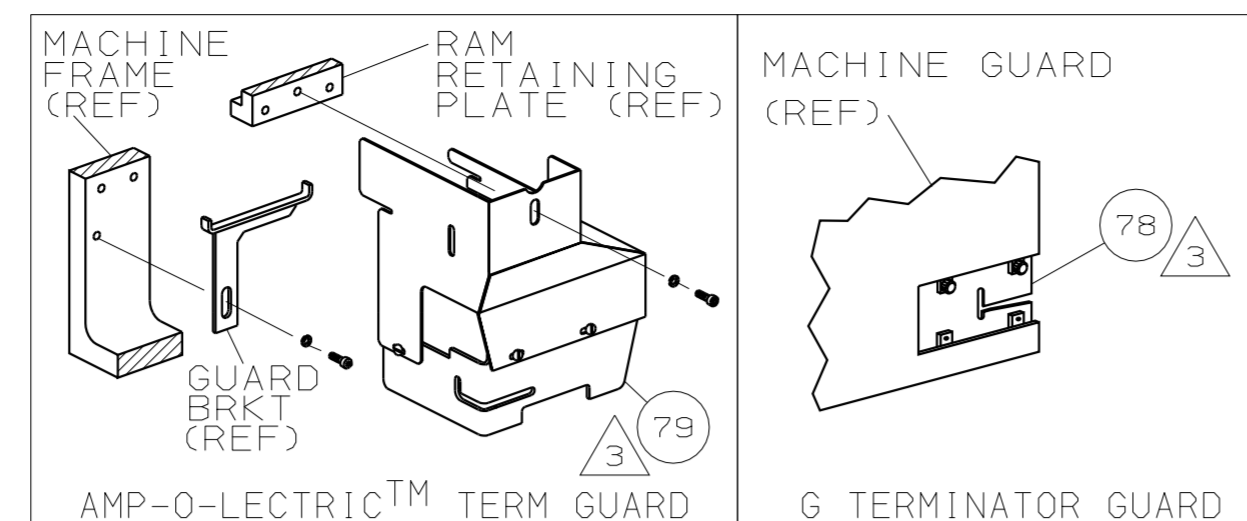

TERMINAL NAME: .250 SRS FASTIN-ON REC.				
160913 CRIMP DATA (AMP TERMINAL)				
PAD LTR	CRIMP HEIGHT	WIRE SIZE		
A	.094 ±.002 [2.38 ±0.05mm]	4.00mm ²		
B	.089 ±.002 [2.26 ±0.05mm]	3.50mm ²		
C	.085 ±.002 [2.16 ±0.05mm]	3.00mm ²		
D	NOT	USED		
CRIMP	SIZE	TYPE	RANGE	
WIRE	.130 [3.30mm]	F	3.00-4.00mm ²	
INSUL	.210 [5.33mm]	F	ø3.3-4.5mm	
WIRE STRIP LENGTH	TERM APPL SPEC	FEED	APPL INSTRUCTION	SET UP GAGE LAYOUT
.188-.203	114-2036	.845	408-8039	458638-1 L2167

-1 LEADMAKER & BENCH MODEL G		MECH POST FEED				
-2 BENCH MODEL K		MECH POST FEED				
REF	REF	-	A	22594-8	NUT, HEX	70
REF	REF	-	B	240628-1	PLATE, ADJ	69
REF	REF	-	B	240626-1	SHAFT, PIVOT	68
REF	REF	-	B	240633-1	BUSHING	67
REF	REF	-	A	455680-1	LEVER, INTERMEDIATE	66
REF	REF	-	B	240629-1	BLOCK, PIVOT	65
REF	REF	-	A	240632-2	SCR, ADJ	64
REF	REF	-	B	240659-3	PIN, CAM ROLLER	63
REF	REF	-	B	240658-1	CAM, ROLLER	62
REF	REF	-	B	454398-1	ROD, FEED	61
REF	REF	-	C	454220-1	CAP, RAM	59
REF	REF	-	D	453736-1	HOUSING	58
REF	REF	-	B	240624-1	PIN, FEED FINGER	55
REF	REF	-	B	691499-1	SPRING, FEED FINGER	54
REF	REF	-	B	240635-1	FINGER, FEED	53
REF	REF	-	B	240634-3	LEVER, TERMINAL	52
REF	REF	-	B	690501-3	CAM, POST FEED 1 1/8 ST	48
REF	REF	-	B	690501-4	CAM, POST-FEED 1 5/8 ST	47
REF	REF	-	A	690191-1	PLUG, NYLON	45
REF	REF	-	C	455674-1	RAM	44
REF	REF	-	A	690125-1	WASHER, LAMINATED	43
REF	REF	-	A	690124-1	WASHER, RAM	42
REF	REF	-	A	7-21002-9	BOLT, CRIMPER (5/16-24x1.00)	41
REF	REF	-	A	23241-6	BALL, STEEL	40
REF	REF	-	A	690170-1	SPRING, COMPRESSION	39
REF	REF	-	C	690142-1	DISC, INSULATION	38
REF	REF	-	D	354777-1	WIRE DISC, PLASTIC	37
REF	REF	-	A	22480-5	WASHER, SPRING	36
REF	REF	-	B	690212-1	POST, RAM	35
REF	REF	-	A	458980-2	APPLICATOR, BASIC (SUB ASSY)	32
REF	REF	-	A	690455-3	STRIPPER	27
REF	REF	-	C	455676-1	PLATE, BASE	26
REF	REF	-	A	22354-8	DRAG, STUD	25
REF	REF	-	B	458803-8	PLATE, STRIP GUIDE	24
REF	REF	-	A	4-22281-1	SPRING, DRAG	22
REF	REF	-	A	454177-1	DRAG, STOCK	20
REF	REF	-	B	2-690481-0	TERMINAL, HOLD DOWN	13
REF	REF	-	A	23846-1	SPRING, HOLD DOWN	12
REF	REF	-	B	240833-4	PLATE, REAR SHEAR	11
REF	REF	-	B	1-690482-0	PLATE, FRONT SHEAR	9
REF	REF	-	D	2-356038-5	ANVIL	8
REF	REF	-	B	690474-3	BLADE, SLUG	7
REF	REF	-	D	2-455892-7	HOLD DOWN, TERMINAL	6
REF	REF	-	C	4-240641-6	SPACER, SLUG BLADE	5
REF	REF	-	B	238009-2	SPACER, BLOCK CRIMPER	4
REF	REF	-	C	1-683453-7	CRIMPER, INSULATION	3
REF	REF	-	B	1-455888-1	SPACER, CRIMPER	2
REF	REF	-	C	1-456410-2	CRIMPER, WIRE	1

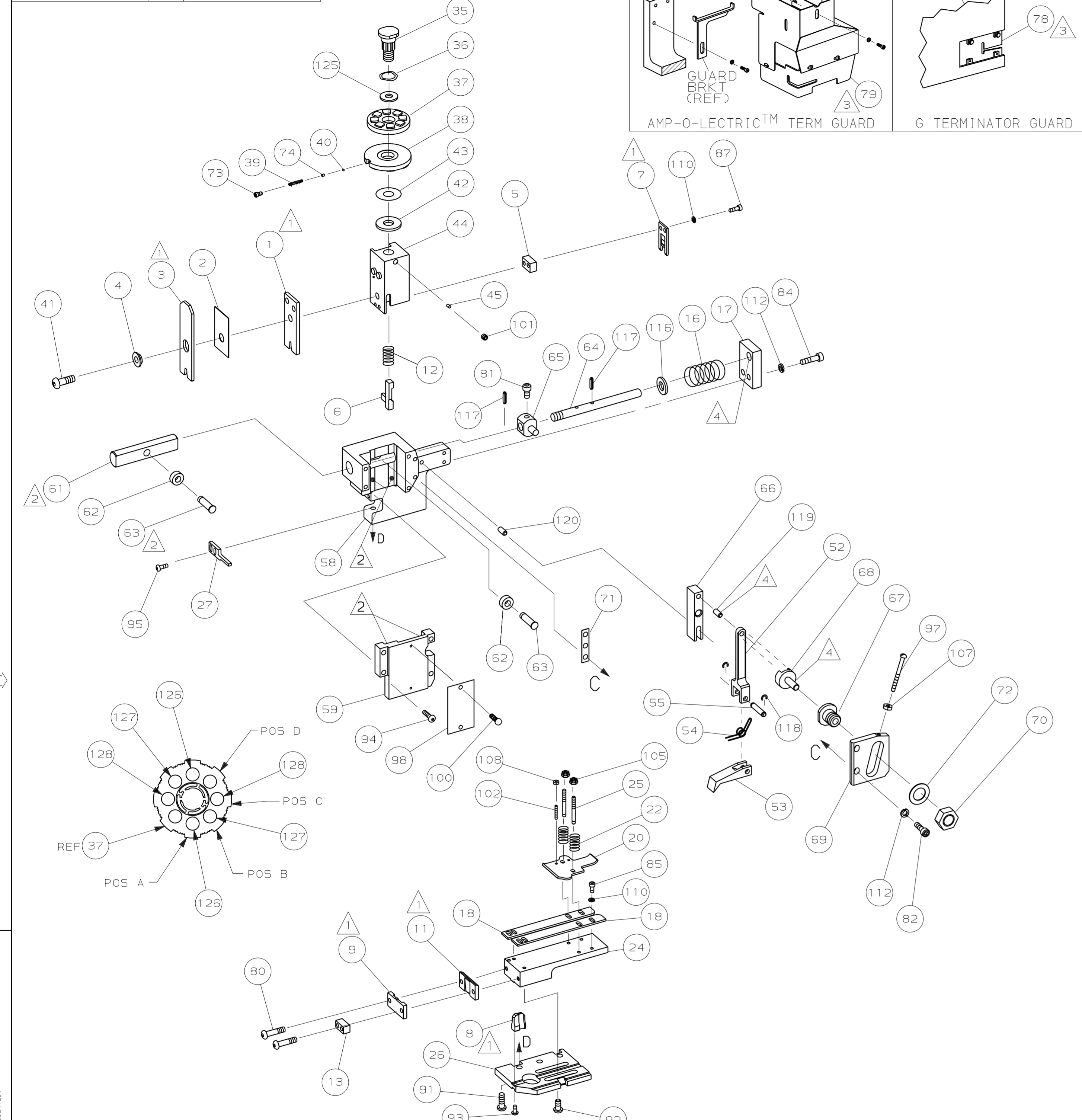

QTY	REV	U/M	DWG SIZE	PART NO	DESCRIPTION	ITEM NO
2	2	-	C	6-354778-6	PIN WIRE DISC (.2825)C	129
2	2	-	C	5-354778-8	PIN WIRE DISC (.2785)B	127
2	2	-	C	4-354778-7	PIN WIRE DISC (.2730)A	126
1	1	-	A	986950-1	WASHER, FLAT PRECISION	125
1	1	-	A	217238-1	GENERAL INSTRUCTION PACKAGE	124
1	1	-	-	4088039	EF APPL INST 408-8039	123
REF	REF	-	A	1-21030-7	PIN, DOWEL (ø.187x1.50)HSG	120
REF	REF	-	A	1-21030-1	PIN, DOWEL (ø.187x.50)LEVER	119
REF	REF	-	A	21045-3	RING, RET "C" (ø.187)FD PIN	118
REF	REF	-	A	5-21028-1	PIN, STD SPRING (ø.12)FD ADJ ROD	117
REF	REF	-	A	21899-4	WASHER, FLAT (ø5/16)SCR ADJ	116
REF	REF	-	A	21024-5	WASHER, LOCK (NO.10)FD ROD GDE	112
6	6	-	A	21024-4	WASHER, LOCK (NO.8)SHEAR BL	110
2	2	-	A	21018-4	NUT, HEX (4-40)DRAG	108
REF	REF	-	A	21018-5	NUT, HEX (6-32)FD ADJ PL	107
2	2	-	A	21022-2	NUT, HEX SL (8-32)DRAG STUD	105
2	2	-	A	2-21006-6	SCR, SKT SET (4-40x.62)DRAG	102
1	1	-	A	21009-2	SCR, SKT SET (1/4-20x.25)RAM	101
2	2	-	A	21017-2	SCR, DRIVE (#2x.19)ID PLATE	100
1	1	-	A	1-21002-7	SCR, BHC (6-32x.38)CAM	99
1	1	-	B	461264-1	PLATE, IDENTIFICATION	98
REF	REF	-	A	6-23715-5	SCR, PAN HD (6-32x1.50)FEED ADJ	97
2	2	-	A	2-21002-2	SCR, BHC (8-32x.50)STRIPPER	95
REF	REF	-	A	2-21002-9	SCR, BHC (10-32x.75)HSG CAP	94
1	1	-	A	22733-8	SCR, BHC (8-32x.38 LW)ANVIL	93
4	4	-	A	3-21002-3	SCR, BHC (1/4-20x.50)ST GD PL	92
REF	REF	-	A	2-22733-8	SCR, BHC (1/4-20x.62)BASE PL	91
REF	REF	-	A	3-21000-6	SCR, SHC (8-32x.38)STRIP GUIDE	85
REF	REF	-	A	3-21000-7	SCR, SHC (10-32x.75)FEED ROD GDE	84
REF	REF	-	A	3-21000-6	SCR, SHC (10-32x.62)FEED ADJ PL	82
REF	REF	-	A	3-21000-4	SCR, SHC (10-32x.38)PIVOT BLOCK	81
2	2	-	A	3-21002-0	SCR, BHC (10-32x.88)SHEAR PL	80
REF	-	-	A	455745-1	GUARD, WINDOW	79
-	REF	-	A	679532-1	INSERT, GUARD	78
1	1	-	A	690603-1	SPRING, ASSIST	74
1	1	-	A	23030-1	SCR, SKT CAP (6-32x.25)CP DSC	73
REF	REF	-	A	458109-1	WASHER, FLAT (SPECIAL)	72
REF	REF	-	A	690517-1	SPACER	71

POST-FEED 1 5/8 STROKE POST-FEED 1 1/8 STROKE POST-FEED 1 5/8 STROKE

LOC A LEADMAKER K TERMINATOR BENCH MACHINE G TERMINATOR BENCH MACHINE

1 RECOMMENDED SPARE PARTS.
 2 GREASE LIGHTLY.
 3 GUARD MUST BE IN PLACE WHEN OPERATING APPLICATOR IN A BENCH MACHINE.
 4 LUBRICATE DAILY USING NO. 20 MACHINE OIL.
 5. ITEMS WITH QTY OF REF SPECIFIED (EXCEPT ITEMS 78 AND 79) ARE USED ON ITEM 32.
 6 ITEM 78 USED WITH G TERMINATOR ONLY.

QTY REOD PER ASSY PARTS LIST

QTY	REV	U/M	DWG SIZE	PART NO	DESCRIPTION	ITEM NO
-2	-1	U/M	DWG SIZE	PART NO	DESCRIPTION	ITEM NO

REVISION OF EACH ASSY NO (WHEN BLANK, USE DWG REVISION)

DIMENSIONS IN INCHES. DO NOT SCALE PRINT.
 TOLERANCES UNLESS OTHERWISE SPECIFIED:
 2 PLC DEC ±
 3 PLC DEC ±
 4 PLC DEC ±
 ANGLES ±
 SURF TEXTURE: ✓
 REMOVE BURRS, BREAK SHARP EDGES R.015 MAX

MATL - HT TR - FIN -

DR W.HOOVER APP 05NOV98 T.ELBIN
 CHK 05NOV98 REL -
 C.ERISMAN

AMP AMP Incorporated Harrisburg, PA 17105-3608

NAME END FEED HDM APPLICATOR MACHINE REF MINI APPL

SCALE - DWG NO 680744 SHEET 1 OF 1 REV B1

CAGE CODE 00779 CUSTOMER AND ASSEMBLY DRAWING RESTRICTED TO

THIS DRAWING IS A CONTROLLED DOCUMENT.

RELEASED FOR PUBLICATION 2/FEB/1999 BY AMP INCORPORATED. ALL RIGHTS RESERVED. AMP 1756 REV 3-92 27-FEB-02 13:48:28 amp16926

680744