



STW38NB20

N-CHANNEL 200V - 0.052 Ω - 38A TO-247

PowerMESH™ MOSFET

PRELIMINARY DATA

Table 1. General Features

Type	V _{DSS}	R _{DS(on)}	I _D
STW38NB20	200 V	< 0.065 Ω	38 A

FEATURES SUMMARY

- TYPICAL R_{DS(on)} = 0.052 Ω
- EXTREMELY HIGH dv/dt CAPABILITY
- \pm 30V GATE TO SOURCE VOLTAGE RATING
- 100% AVALANCHE TESTED
- LOW INTRINSIC CAPACITANCE
- GATE CHARGE MINIMIZED
- REDUCED VOLTAGE SPREAD

DESCRIPTION

Using the latest high voltage MESH OVERLAY™ process, STMicroelectronics has designed an advanced family of power MOSFETs with outstanding performances. The new patent pending strip layout coupled with the Company's proprietary edge termination structure, gives the lowest R_{DS(on)} per area, exceptional avalanche and dv/dt capabilities and unrivalled gate charge and switching characteristics.

APPLICATIONS

- HIGH CURRENT, HIGH SPEED SWITCHING
- SWITCH MODE POWER SUPPLY (SMPS)
- DC-AC CONVERTER FOR WELDING EQUIPMENT AND UNINTERRUPTABLE POWER SUPPLY AND MOTOR DRIVE

Figure 1. Package

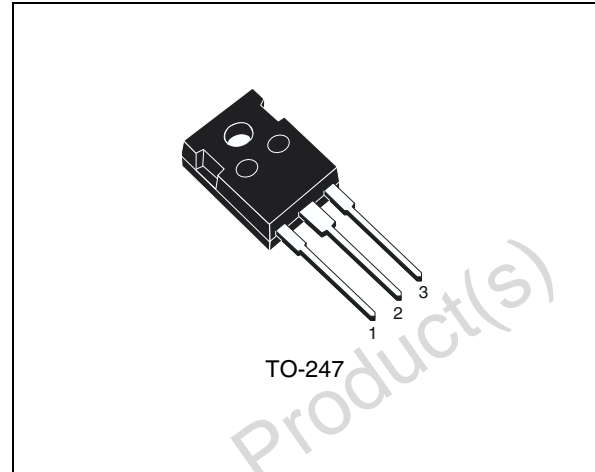

Figure 2. Internal Schematic Diagram

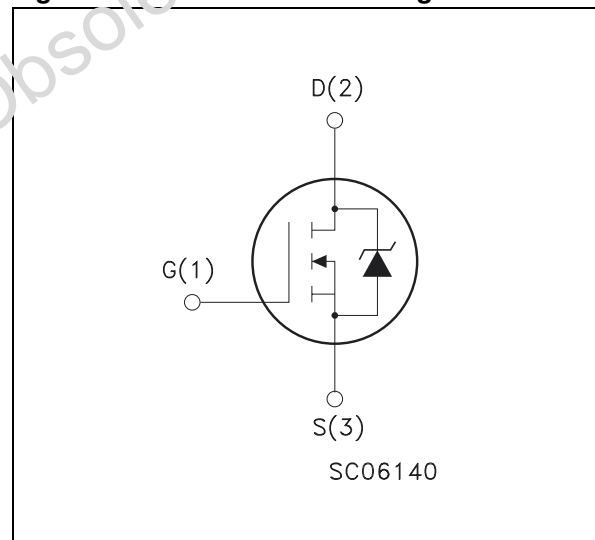

Table 2. Order Codes

Part Number	Marking	Package	Packaging
STW38NB20	W38NB20	TO-247	TUBE

Table 3. Absolute Maximum Ratings

Symbol	Parameter	Value	Unit
V _{DS}	Drain-source Voltage (V _{GS} = 0)	200	V
V _{DGR}	Drain- gate Voltage (R _{GS} = 20 kΩ)	200	V
V _{GS}	Gate-source Voltage	± 30	V
I _D	Drain Current (cont.) at T _C = 25 °C	38	A
I _D	Drain Current (cont.) at T _C = 100 °C	24	A
I _{DM} ⁽¹⁾	Drain Current (pulsed)	152	A
P _{tot}	Total Dissipation at T _C = 25 °C	180	W
	Derating Factor	1.44	W/°C
dv/dt ⁽²⁾	Peak Diode Recovery voltage slope	5.5	V/ns
T _{stg}	Storage Temperature	-65 to 150	°C
T _j	Max. Operating Junction Temperature	150	°C

Note: 1. Pulse width limited by safe operating area
 2. I_{SD} ≤ 38 A, di/dt ≤ 200 A/μs, V_{DD} ≤ V_{(BR)DSS}, T_j ≤ T_{JMAX}

Table 4. Thermal Data

Symbol	Parameter	Value	Unit
R _{thj-case}	Thermal Resistance Junction-case Max	0.69	°C/W
R _{thj-amb}	Thermal Resistance Junction-ambient Max	30	°C/W
T _l	Maximum Lead Temperature For Soldering Purpose	300	°C

Table 5. Avalanche Characteristics

Symbol	Parameter	Max Value	Unit
I _{AR}	Avalanche Current, Repetitive or Not-Repetitive (pulse width limited by T _j max, δ < 1%)	38	A
E _{AS}	Single Pulse Avalanche Energy (starting T _j = 25 °C; I _D = I _{AR} ; V _{DD} = 50 V)	550	mJ

ELECTRICAL CHARACTERISTICS ($T_{\text{case}} = 25^{\circ}\text{C}$ unless otherwise specified)**Table 6. Off**

Symbol	Parameter	Test Conditions	Min.	Typ.	Max.	Unit
$V_{(\text{BR})\text{DSS}}$	Drain-source Breakdown Voltage	$I_{\text{D}} = 250 \text{ mA}$ $V_{\text{GS}} = 0$	200			V
I_{DSS}	Zero Gate Voltage Drain Current ($V_{\text{GS}} = 0$)	$V_{\text{DS}} = \text{Max Rating}$ $V_{\text{DS}} = \text{Max Rating}$ $T_{\text{c}} = 125^{\circ}\text{C}$			1 10	μA μA
I_{GSS}	Gate-body Leakage Current ($V_{\text{DS}} = 0$)	$V_{\text{GS}} = \pm 30 \text{ V}$			± 100	nA

Table 7. On (1)

Symbol	Parameter	Test Conditions	Min.	Typ.	Max.	Unit
$V_{\text{GS}(\text{th})}$	Gate Threshold Voltage	$V_{\text{DS}} = V_{\text{GS}}$; $I_{\text{D}} = 250 \mu\text{A}$	3	4	5	V
$R_{\text{DS}(\text{on})}$	Static Drain-source On Resistance	$V_{\text{GS}} = 10 \text{ V}$; $I_{\text{D}} = 19 \text{ A}$		0.052	0.065	Ω

Note: 1. Pulsed: Pulse duration = 300 μs , duty cycle 1.5 %

Table 8. Dynamic

Symbol	Parameter	Test Conditions	Min.	Typ.	Max.	Unit
g_{fs} (1)	Forward Transconductance	$V_{\text{DS}} > I_{\text{D}(\text{on})} \times R_{\text{DS}(\text{on})\text{max}}$; $I_{\text{D}} = 19 \text{ A}$	10	19		S
C_{iss}	Input Capacitance	$V_{\text{DS}} = 25 \text{ V}$; $f = 1 \text{ MHz}$; $V_{\text{GS}} = 0$		2800	3800	pF
C_{oss}	Output Capacitance			750	1000	pF
C_{rss}	Reverse Transfer Capacitance			100	140	pF

Note: 1. Pulsed: Pulse duration = 300 μs , duty cycle 1.5 %

Table 9. Switching On

Symbol	Parameter	Test Conditions	Min.	Typ.	Max.	Unit
$t_{\text{d}(\text{on})}$	Turn-on Time	$V_{\text{DD}} = 100 \text{ V}$ $I_{\text{D}} = 19 \text{ A}$; $R_{\text{G}} = 4.7 \Omega$ $V_{\text{GS}} = 10 \text{ V}$ (see test circuit)		35	47	ns
t_{r}	Rise Time			40	55	ns
Q_{g}	Total Gate Charge	$V_{\text{DD}} = 160 \text{ V}$; $I_{\text{D}} = 38 \text{ A}$; $V_{\text{GS}} = 10 \text{ V}$		70	95	nC
Q_{gs}	Gate-Source Charge			22		nC
Q_{gd}	Gate-Drain Charge			35		nC

Table 10. Switching Off

Symbol	Parameter	Test Conditions	Min.	Typ.	Max.	Unit
$t_{\text{r}(\text{Voff})}$	Off-voltage Rise Time	$V_{\text{DD}} = 160 \text{ V}$ $I_{\text{D}} = 38 \text{ A}$; $R_{\text{G}} = 4.7 \Omega$; $V_{\text{GS}} = 10 \text{ V}$		18	24	ns
t_{f}	Fall Time			22	30	ns
t_{c}	Cross-over Time			42	57	ns

Table 11. Source Drain Diode

Symbol	Parameter	Test Conditions	Min.	Typ.	Max.	Unit
I_{SD}	Source-drain Current				38	A
$I_{SDM}^{(1)}$	Source-drain Current (pulsed)				152	A
$V_{SD}^{(2)}$	Forward On Voltage	$I_{SD} = 38 \text{ A}; V_{GS} = 0$			1.5	V
t_{rr}	Reverse Recovery Time	$I_{SD} = 38 \text{ A}; di/dt = 100 \text{ A}/\mu\text{s}$ $V_{DD} = 50 \text{ V}; T_j = 150 \text{ }^\circ\text{C}$		350		ns
Q_{rr}	Reverse Recovery Charge			2.3		μC
I_{RRM}	Reverse Recovery Current			13		A

Note: 1. Pulse width limited by safe operating area
2. Pulsed: Pulse duration = 300 μs , duty cycle 1.5 %

Obsolete Product(s) - Obsolete Product(s)

PACKAGE MECHANICAL

Table 12. TO-247 Mechanical Data

Symbol	millimeters			inches		
	Min	Typ	Max	Min	Typ	Max
A	4.85		5.15	0.19		0.20
A1	2.20		2.60	0.086		0.102
b	1.0		1.40	0.039		0.055
b1	2.0		2.40	0.079		0.094
b2	3.0		3.40	0.118		0.134
c	0.40		0.80	0.015		0.03
D	19.85		20.15	0.781		0.793
E	15.45		15.75	0.608		0.620
e		5.45			0.214	
L	14.20		14.80	0.560		0.582
L1	3.70		4.30	0.14		0.17
L2		18.50			0.728	
ØP	3.55		3.65	0.140		0.143
ØR	4.50		5.50	0.177		0.216
S		5.50			0.216	

Figure 3. TO-247 Package Dimensions

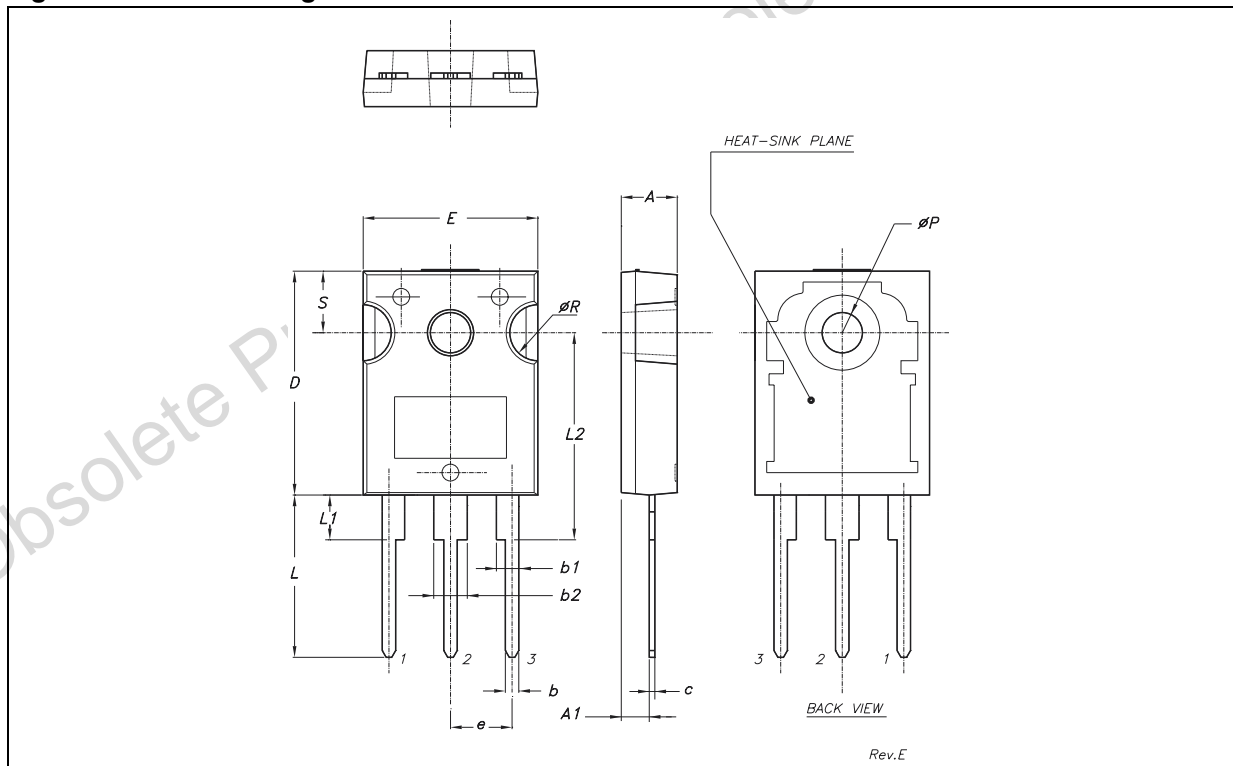

REVISION HISTORY

Table 13. Revision History

Date	Revision	Description of Changes
January-1998	1	First Issue
14-Apr-2004	2	Stylesheet update. No content change.

Obsolete Product(s) - Obsolete Product(s)

Information furnished is believed to be accurate and reliable. However, STMicroelectronics assumes no responsibility for the consequences of use of such information nor for any infringement of patents or other rights of third parties which may result from its use. No license is granted by implication or otherwise under any patent or patent rights of STMicroelectronics. Specifications mentioned in this publication are subject to change without notice. This publication supersedes and replaces all information previously supplied. STMicroelectronics products are not authorized for use as critical components in life support devices or systems without express written approval of STMicroelectronics.

The ST logo is a registered trademark of STMicroelectronics.
All other names are the property of their respective owners

© 2004 STMicroelectronics - All rights reserved

STMicroelectronics GROUP OF COMPANIES

Australia - Belgium - Brazil - Canada - China - Czech Republic - Finland - France - Germany - Hong Kong - India - Israel - Italy - Japan -
Malaysia - Malta - Morocco - Singapore - Spain - Sweden - Switzerland - United Kingdom - United States

www.st.com