



SIGN	DATE	DESCRIPTION	APPROVER
		THIS IS CAD DRAWING, DO NOT REVISE MANUALLY!!!	

Material

- Terminal body (Contact pin): PhBz
- Surface of solder tail: Tin plated
- Insulator (housing): Thermoplastic (UL94V-0)

Electrical cULus/VDE

- Voltage rating: 300VAC/250VAC
- Current rating: 2A/2A
- Wire range: 0.5-0.75mm²
Solid wire(AWG): 18
Stranded wire(AWG): 18
- Wire strip length: 6-7mm
- Withstanding Voltage: 1.6KV/2KV
- Operating temperature: -30°C to +105°C
- Soldering temperature: 250°C±10°C/5 Sec
- Safety Approval:  

RoHS Compliant

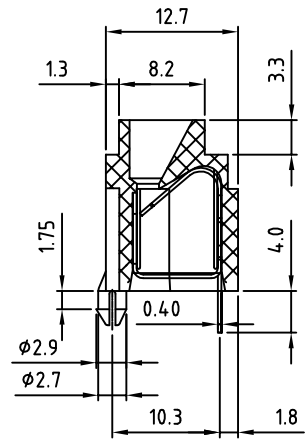
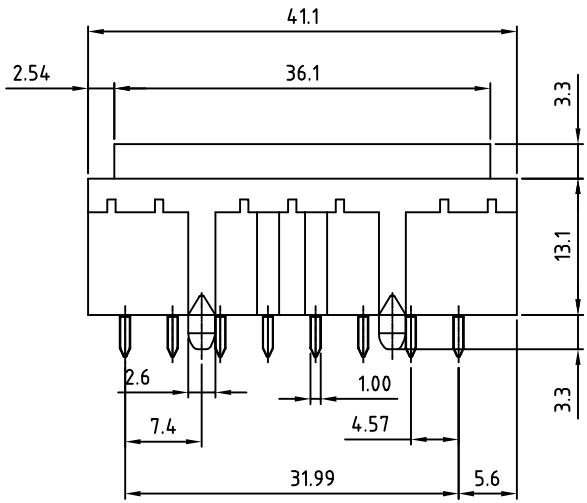
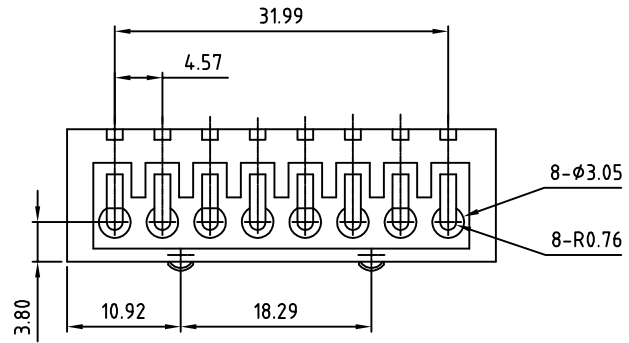

THESE DRAWINGS AND SPECIFICATIONS ARE THE PROPERTY OF ON-SHORE TECHNOLOGY, INC. AND SHALL NOT BE REPRODUCED, COPIED OR USED IN ANY MANNER WITHOUT THE PRIOR WRITTEN CONSENT OF ON-SHORE TECHNOLOGY, INC.



TITLE	OSTTN-4.57mm Series 8P W/o cover						
PART NO.	OSTTN081900			DWG NO.	OSTTN081900.DWG		
APPROVED	CHECKED	DESIGNED	DRAWN	CUST NO.	Tolerance		
	Marvin 2008.03.13	Marvin 2006.08.21	Marvin 2006.08.21		UNIT: mm	X.	±0.50
				SHEET: 01/01	SCALE: NONE	X.X	±0.30
					REV: B	X.XX	±0.10
						X°	±1°