

# 0-2236059-1 AND 0-2236059-2

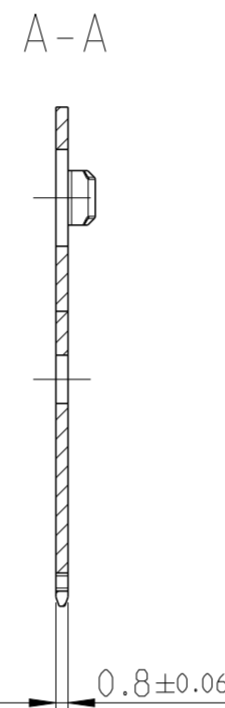
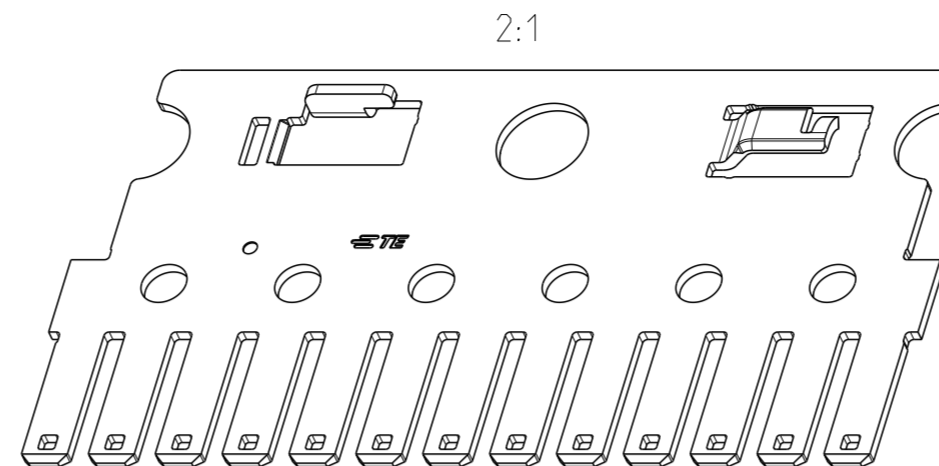
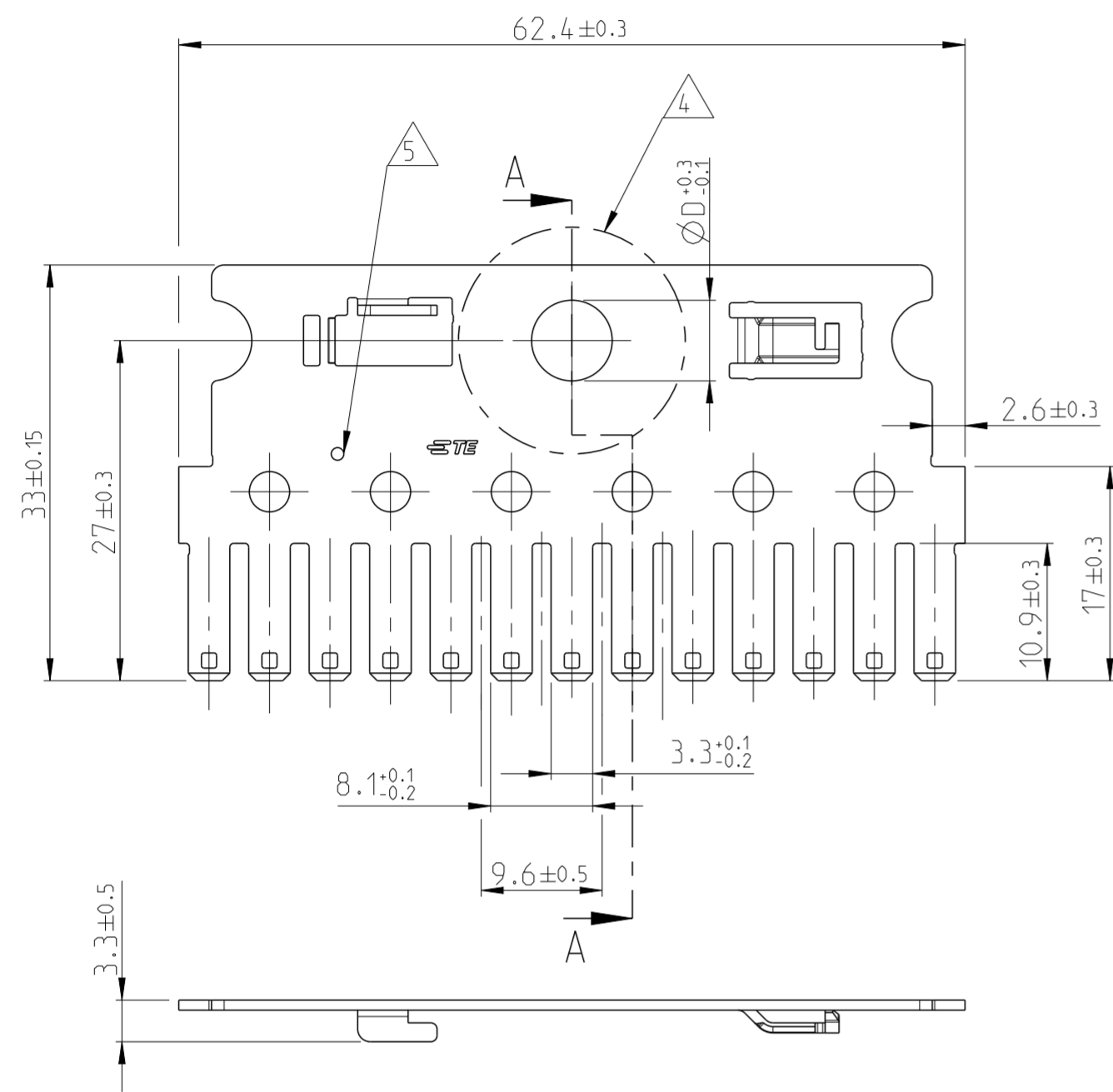

NOTES:

1. STAMPING EDGE WITHOUT Sn PLATING
  2. PART NUMBER 0-2236059-1 AS SHOWN
  3. PART IS SHOWN IN DELIVERY CONDITION
- △ OUTER DIAMETER FOR WRENCH (NUT) MAX. 18MM  
 △ REVISION STATUS OF PRODUCT. MARKED WITH CENTER PUNCH

LOC		DIST		REVISIONS			
P	LTR	DESCRIPTION	DATE	DWN	APVD		
A1	-	new drawing	24APR2013	CS	HR		
A1	-	see PCN E-16-018152. ADDED 0-2236059-3	22DEC2016	CS	HR		
A2	-	E-20-010773; 2236059-4 and 2236059-5 ADDED	29JULY2020	MT	HR		

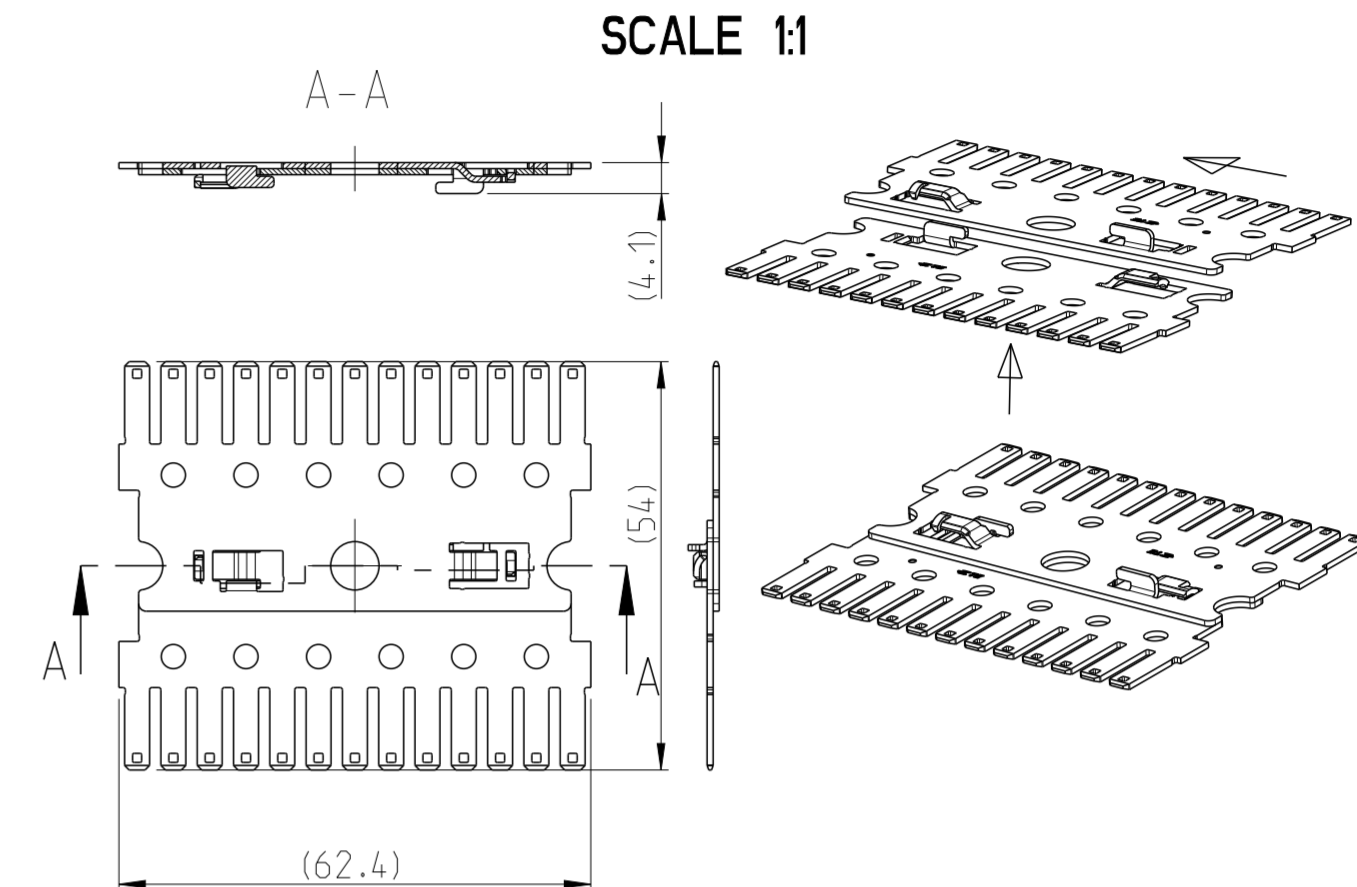

**POSSIBILITY TO LOCK  
 BRANCH CONNECTOR TOGETHER  
 (NON DELIVERY CONDITION)**

## VERSIONS WITH ANTI ROTATION FEATURES AND OCTAGON

ALL MISSING DIMENSIONS SEE 2236059-1

### 2236059-3

ALL MISSING DIMENSIONS SEE 2236059-1

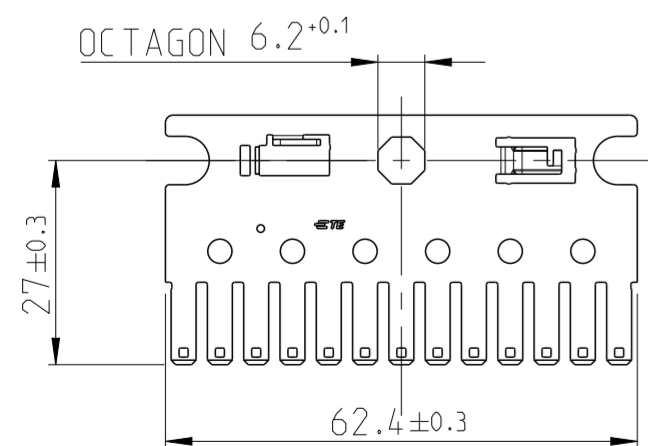

### 2236059-4

1:1

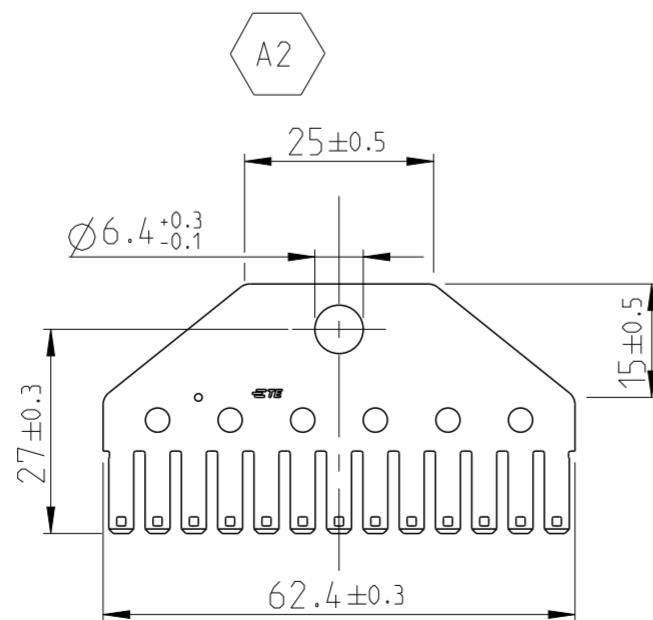

### 2236059-5

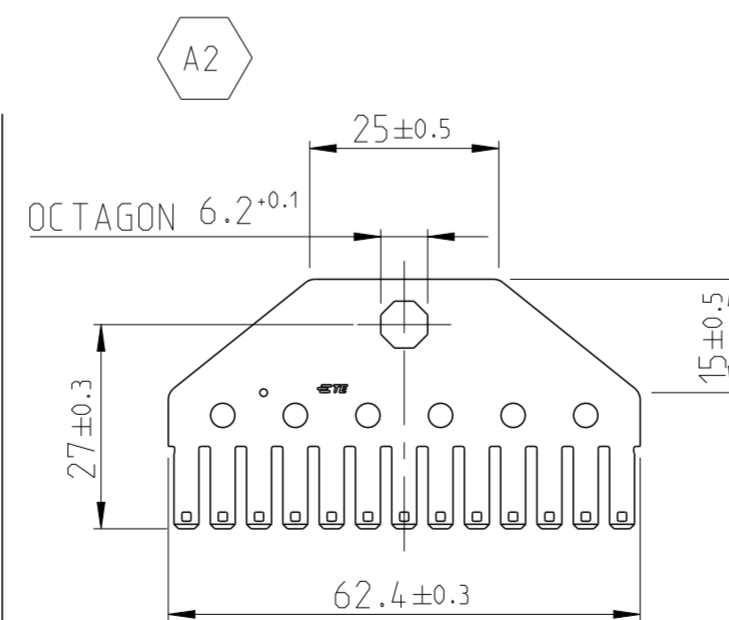

○	B
○	A
MARKING	REV.

USED FEMALE TERMINALS		
1-962889-1	TIN	0.2-0.5
1-962890-1	TIN	0.75-1.0
1-962891-1	TIN	1.5-2.5
1-962892-1	TIN	4.0-6.0
TE CONNECTIVITY PART NUMBER	FINISH	WIRE SIZE [mm <sup>2</sup> ]

SCREW	DIMENSION D	WEIGHT [g]	PART NUMBER	REV
M6	Ø6.4	10.2	2236059-5	A
M6	Ø6.4	10.2	2236059-4	A
M8	Ø8.4	10.7	2236059-3	A
M6	Ø6.4	11.1	2236059-2	A

-1 AS SHOWN

THIS DRAWING IS A CONTROLLED DOCUMENT.

DIMENSIONS: mm	TOLERANCES UNLESS OTHERWISE SPECIFIED:	DWN C. SCHAAD 24.APR2013	APVD G. MUMPER 24.APR2013
		CHK H. RIPPER 24.APR2013	
		PRODUCT SPEC 108-94391	
		APPLICATION SPEC 114-94254	
MATERIAL Cu-OF R360	FINISH PRE TIN 4-10 µm Sn	WEIGHT (see chart)	Customer Drawing

NAME: 13 WAY BRANCH CONNECTOR WITH SCREW FIXING (LP)

SIZE A2	CAGE CODE 00779	DRAWING NO. C-2236059	RESTRICTED TO
SCALE 5:1	SHEET 1 OF 1	REV A2	