

THIS DRAWING IS UNPUBLISHED. RELEASED FOR PUBLICATION  
 © COPYRIGHT BY TYCO ELECTRONICS CORPORATION. ALL RIGHTS RESERVED.

LOC	DIST	REVISIONS			
P	LTR	DESCRIPTION	DATE	DWN	APVD
AG	53	0	RELEASED.	21SEP2005	JGH/JGH

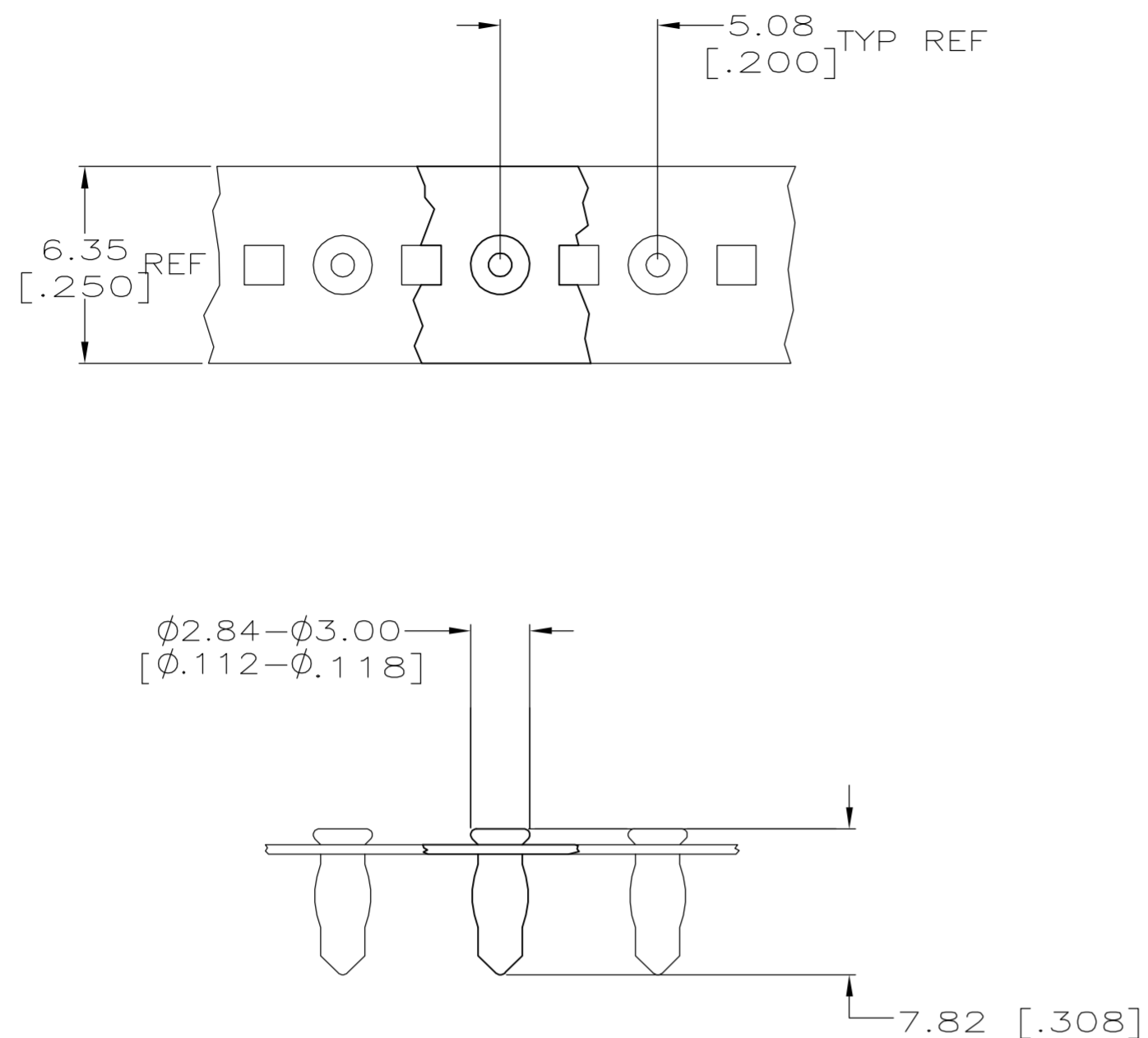

- 1 MATERIAL:  
EYELET - COPPER PER ASTM B 152  
SPRING - BERYLLIUM COPPER PER ASTM B 194
- 2 TIN PLATE PER ASTM B 545 0.00381 [.000150] MIN THICK.
- 3 TIN PLATE PER ASTM B 545 0.00254 [.000100] MIN THICK.
- 4 GOLD PLATE PER ASTM B 488 0.00076 [.000030] MIN THICK ON CONTACT AREA.
- 5 PACKAGED 25,000 PER REEL
- 6 TO INSURE 1/2 OZ MIN RETENTION DO NOT EXCEED 0.10 [.004] DIFFERENCE IN PIN DIA WHEN CHANGING TO A SMALLER DIA PIN
- 7 PRODUCT IS OVALIZED FOR RETENTION IN THE P.C. BOARD. THE RECOMMENDED HOLE DIAMETER IS  $\phi 2.59$  [ $\phi .102$ ] MINIMUM,  $+0.08$  [.003] MAX. PRIOR TO SOLDERING.
- 8 PACKAGED 10,000 PER REEL

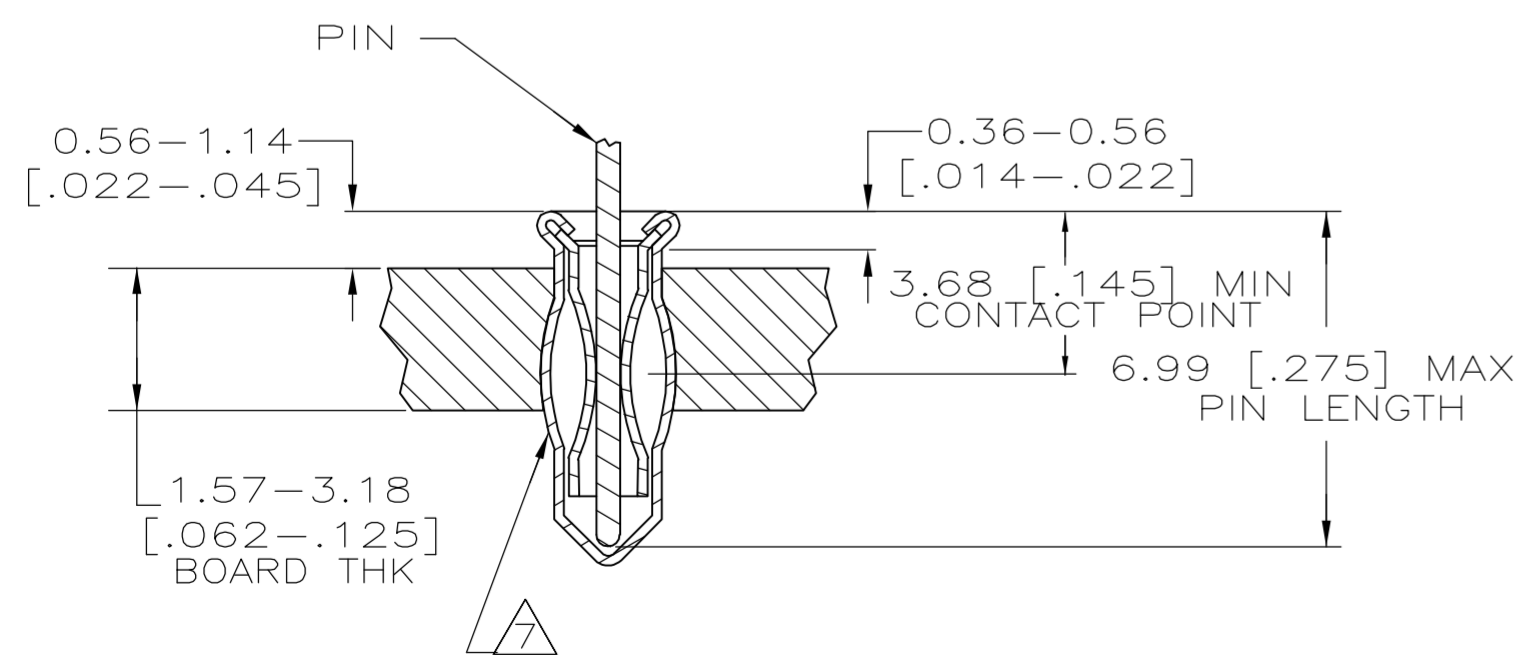

3.76-6.99 [.145-.275]	$\phi 1.07-\phi 1.24$ [ $\phi .042-\phi .049$ ]	GOLD 4	TIN 2	1-5645979-2 8
3.76-6.99 [.145-.275]	$\phi 1.07-\phi 1.24$ [ $\phi .042-\phi .049$ ]	TIN 3	TIN 2	5645979-1 5
LENGTH	DIAMETER	SPRING	EYELET	PART NUMBER
PIN		FINISH		

THIS DRAWING IS A CONTROLLED DOCUMENT.		DWN J. HAVENER 21SEP2005	Tyco Electronics Corporation Harrisburg, PA 17105-3608	
DIMENSIONS: mm [INCHES]		CHK J. HAVENER 21SEP2005		
TOLERANCES UNLESS OTHERWISE SPECIFIED:		APVD J. HAVENER 21SEP2005		
0 PLC ± - 1 PLC ± - 2 PLC ± - 3 PLC ± 0.20 [.008] 4 PLC ± - ANGLES ± -		NAME		
MATERIAL 1		FINISH SEE TABLE	MINIATURE SPRING SOCKET ASSY SERIES 5 WITHOUT SEALANT	
		WEIGHT -	SIZE A2	CAGE CODE 00779
		CUSTOMER DRAWING	DRAWING NO C=5645979	RESTRICTED TO -
			SCALE 10:1	SHEET 1 of 1
				REV 0