

REVISIONS

| LTR | DESCRIPTION   | DATE (YR-MO-DA) | APPROVED   |
|-----|---|-----------------|------------|
| A   | Changes in accordance with N.O.R. 5962-R167-92.       | 92-12-15        | M. A. FRYE |
| B   | Drawing updated to reflect current requirements. - ro | 02-09-23        | R. MONNIN  |

THE FIRST SHEET OF THIS DRAWING HAS BEEN REPLACED.

|       |  |  |  |  |  |  |  |  |  |  |  |  |  |  |  |  |  |  |  |  |
|-------|--|--|--|--|--|--|--|--|--|--|--|--|--|--|--|--|--|--|--|--|
| REV   |  |  |  |  |  |  |  |  |  |  |  |  |  |  |  |  |  |  |  |  |
| SHEET |  |  |  |  |  |  |  |  |  |  |  |  |  |  |  |  |  |  |  |  |
| REV   |  |  |  |  |  |  |  |  |  |  |  |  |  |  |  |  |  |  |  |  |
| SHEET |  |  |  |  |  |  |  |  |  |  |  |  |  |  |  |  |  |  |  |  |

|            |       |   |   |   |   |   |   |   |   |   |    |    |    |   |   |  |  |
|------------|-------|---|---|---|---|---|---|---|---|---|----|----|----|---|---|--|--|
| REV STATUS | REV   | B | B | B | B | B | B | B | B | B | B  | B  | B  | B | B |  |  |
| OF SHEETS  | SHEET | 1 | 2 | 3 | 4 | 5 | 6 | 7 | 8 | 9 | 10 | 11 | 12 |   |   |  |  |

|   |                                   |   |           |                           |                   |  |  |  |  |  |  |  |  |  |  |
|---|-----------------------------------|---|-----------|---------------------------|-------------------|--|--|--|--|--|--|--|--|--|--|
| PMIC N/A  | PREPARED BY<br>MARCIA B. KELLEHER | <p align="center"><b>DEFENSE SUPPLY CENTER COLUMBUS</b><br/> <b>COLUMBUS, OHIO 43216</b><br/> <a href="http://www.dsc.dla.mil">http://www.dsc.dla.mil</a></p> |           |                           |                   |  |  |  |  |  |  |  |  |  |  |
| <p align="center"><b>STANDARD<br/>MICROCIRCUIT<br/>DRAWING</b></p> <p>THIS DRAWING IS AVAILABLE<br/>FOR USE BY ALL<br/>DEPARTMENTS<br/>AND AGENCIES OF THE<br/>DEPARTMENT OF DEFENSE</p> <p align="center">AMSC N/A</p> | CHECKED BY<br>RAY MONNIN          |   |           |                           |                   |  |  |  |  |  |  |  |  |  |  |
|   | APPROVED BY<br>D. R. COOL         | <p align="center">MICROCIRCUIT, LINEAR, ANALOG SWITCH WITH<br/>DRIVER, MONOLITHIC SILICON</p>   |           |                           |                   |  |  |  |  |  |  |  |  |  |  |
|   | DRAWING APPROVAL DATE<br>88-06-06 |   |           |                           |                   |  |  |  |  |  |  |  |  |  |  |
|   | REVISION LEVEL<br>B               |   | SIZE<br>A | CAGE CODE<br><b>67268</b> | <b>5962-87673</b> |  |  |  |  |  |  |  |  |  |  |
|   |                                   | SHEET 1 OF 12   |           |                           |                   |  |  |  |  |  |  |  |  |  |  |

1. SCOPE

1.1 Scope. This drawing describes device requirements for MIL-STD-883 compliant, non-JAN class level B microcircuits in accordance with MIL-PRF-38535, appendix A.

1.2 Part or Identifying Number (PIN). The complete PIN is as shown in the following example:

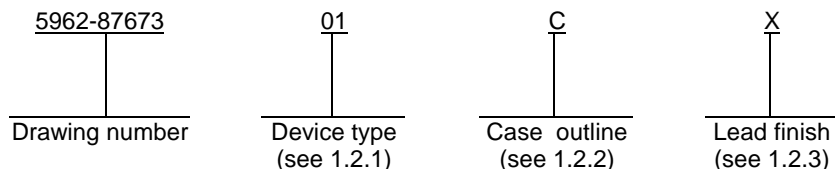

1.2.1 Device type(s). The device type(s) identify the circuit function as follows:

| <u>Device type</u> | <u>Generic number</u> | <u>Circuit function</u>              |
|--------------------|-----------------------|--------------------------------------|
| 01                 | DG180A                | High-speed driver with JFET switches |

1.2.2 Case outline(s). The case outline(s) are as designated in MIL-STD-1835 and as follows:

| <u>Outline letter</u> | <u>Descriptive designator</u> | <u>Terminals</u> | <u>Package style</u> |
|-----------------------|-------------------------------|------------------|----------------------|
| A <sup>1/</sup>       | GDFF5-F14 or CDFP6-F14        | 14               | Flat pack            |
| C                     | GDIP1-T14 or CDIP2-T14        | 14               | Dual-in-line         |
| I                     | MACY1-X10                     | 10               | Can                  |
| X                     | CDFP3-F14                     | 14               | Flat pack            |

1.2.3 Lead finish. The lead finish is as specified in MIL-PRF-38535, appendix A.

1.3 Absolute maximum ratings.

|   |                 |
|---|-----------------|
| Voltage, negative supply to positive supply (+V <sub>CC</sub> to -V <sub>CC</sub> ) ..... | 36 V dc         |
| Voltage, drain to positive supply (+V <sub>CC</sub> to V <sub>D</sub> ) .....             | 33 V dc         |
| Voltage, negative supply to drain (V <sub>D</sub> to -V <sub>CC</sub> ) .....             | 33 V dc         |
| Voltage, source to drain (V <sub>D</sub> to V <sub>S</sub> ).....                         | ±22 V dc        |
| Voltage, negative supply to logic supply (V <sub>L</sub> to -V <sub>CC</sub> ).....       | 36 V dc         |
| Voltage, input to logic supply (V <sub>L</sub> to V <sub>IN</sub> ) .....                 | 8 V dc          |
| Voltage, reference supply to logic supply (V <sub>L</sub> to V <sub>R</sub> ) .....       | 8 V dc          |
| Voltage, reference supply to input (V <sub>IN</sub> to V <sub>R</sub> ) .....             | 8 V dc          |
| Voltage, negative supply to reference supply (V <sub>R</sub> to -V <sub>CC</sub> ).....   | 27 V dc         |
| Voltage, input to reference supply (V <sub>R</sub> to V <sub>IN</sub> ) .....             | 2 V dc          |
| Current, source or drain .....  | 200 mA          |
| Current, all other pins .....   | 30 mA           |
| Lead temperature (soldering, 10 seconds) .....  | +300°C          |
| Storage temperature range .....   | -65°C to +150°C |

<sup>1/</sup> This package is inactive for new design. Acceptable only for use in equipment designed or redesigned on or before 29 November 1986.

|   |                  |                            |  |
|---|------------------|----------------------------|--|
| <b>STANDARD<br/>MICROCIRCUIT DRAWING</b><br>DEFENSE SUPPLY CENTER COLUMBUS<br>COLUMBUS, OHIO 43216-5000 | SIZE<br><b>A</b> | REVISION LEVEL<br><b>B</b> | <b>5962-87673</b><br><br>SHEET<br><b>2</b> |
|---|------------------|----------------------------|--|

1.3 Absolute maximum ratings – Continued.

|   |                  |
|---|------------------|
| Junction temperature (T <sub>J</sub> ) .....                  | +175°C           |
| Power dissipation (P <sub>D</sub> ): <u>2/</u>                |                  |
| Case A .....  | 750 mW           |
| Case C .....  | 825 mW           |
| Case I .....  | 450 mW           |
| Case X .....  | 900 mW           |
| Thermal resistance, junction-to-case (θ <sub>JC</sub> ) ..... | See MIL-STD-1835 |

1.4 Recommended operating conditions.

|   |                 |
|---|-----------------|
| Positive supply voltage (+V <sub>CC</sub> ) .....           | +15 V dc        |
| Negative supply voltage (-V <sub>CC</sub> ) .....           | -15 V dc        |
| Reference supply voltage (V <sub>R</sub> ).....             | GND             |
| Logic supply voltage (V <sub>L</sub> ) .....                | +5 V dc         |
| Ambient operating temperature range (T <sub>A</sub> ) ..... | -55°C to +125°C |

2. APPLICABLE DOCUMENTS

2.1 Government specification, standards, and handbooks. The following specification, standards, and handbooks form a part of this drawing to the extent specified herein. Unless otherwise specified, the issues of these documents are those listed in the issue of the Department of Defense Index of Specifications and Standards (DoDISS) and supplement thereto, cited in the solicitation.

SPECIFICATION

DEPARTMENT OF DEFENSE

MIL-PRF-38535 -- Integrated Circuits, Manufacturing, General Specification for.

STANDARDS

DEPARTMENT OF DEFENSE

MIL-STD-883 - Test Method Standard Microcircuits.  
MIL-STD-1835 - Interface Standard Electronic Component Case Outlines.

HANDBOOKS

DEPARTMENT OF DEFENSE

MIL-HDBK-103 -- List of Standard Microcircuit Drawings.  
MIL-HDBK-780 - Standard Microcircuit Drawings.

(Unless otherwise indicated, copies of the specification, standards, and handbooks are available from the Standardization Document Order Desk, 700 Robbins Avenue, Building 4D, Philadelphia, PA 19111-5094.)

2/ Power ratings based on device mounted with all leads welded or soldered to PC board.  
Derate at +75°C the following cases: case A at 10 mW/°C, case C at 11 mW/°C, case I at 6 mW/°C, and case X at 10 mW/°C.

|  |                  |                            |                   |
|--|------------------|----------------------------|-------------------|
| <b>STANDARD<br/> MICROCIRCUIT DRAWING</b><br>DEFENSE SUPPLY CENTER COLUMBUS<br>COLUMBUS, OHIO 43216-5000 | SIZE<br><b>A</b> |                            | <b>5962-87673</b> |
|  |                  | REVISION LEVEL<br><b>B</b> | SHEET<br><b>3</b> |

2.2 Order of precedence. In the event of a conflict between the text of this drawing and the references cited herein, the text of this drawing takes precedence. Nothing in this document, however, supersedes applicable laws and regulations unless a specific exemption has been obtained.

3. REQUIREMENTS

3.1 Item requirements. The individual item requirements shall be in accordance with MIL-PRF-38535, appendix A for non-JAN class level B devices and as specified herein. Product built to this drawing that is produced by a Qualified Manufacturer Listing (QML) certified and qualified manufacturer or a manufacturer who has been granted transitional certification to MIL-PRF-38535 may be processed as QML product in accordance with the manufacturers approved program plan and qualifying activity approval in accordance with MIL-PRF-38535. This QML flow as documented in the Quality Management (QM) plan may make modifications to the requirements herein. These modifications shall not affect form, fit, or function of the device. These modifications shall not affect the PIN as described herein. A "Q" or "QML" certification mark in accordance with MIL-PRF-38535 is required to identify when the QML flow option is used.

3.2 Design, construction, and physical dimensions. The design, construction, and physical dimensions shall be as specified in MIL-PRF-38535, appendix A and herein.

3.2.1 Case outlines. The case outlines shall be in accordance with 1.2.2 herein.

3.2.2 Terminal connections. The terminal connections shall be as specified on figure 1.

3.2.3 Truth table. The truth table shall be as specified on figure 2.

3.2.4 Logic diagram. The logic diagram shall be as specified on figure 3.

3.2.5 AC switching diagram. The AC switching diagram shall be as specified on figure 4.

3.3 Electrical performance characteristics. Unless otherwise specified herein, the electrical performance characteristics are as specified in table I and shall apply over the full ambient operating temperature range.

3.4 Electrical test requirements. The electrical test requirements shall be the subgroups specified in table II. The electrical tests for each subgroup are described in table I.

3.5 Marking. Marking shall be in accordance with MIL-PRF-38535, appendix A. The part shall be marked with the PIN listed in 1.2 herein. In addition, the manufacturer's PIN may also be marked as listed in MIL-HDBK-103 (see 6.6 herein). For packages where marking of the entire SMD PIN number is not feasible due to space limitations, the manufacturer has the option of not marking the "5962-" on the device.

3.5.1 Certification/compliance mark. A compliance indicator "C" shall be marked on all non-JAN devices built in compliance to MIL-PRF-38535, appendix A. The compliance indicator "C" shall be replaced with a "Q" or "QML" certification mark in accordance with MIL-PRF-38535 to identify when the QML flow option is used.

3.6 Certificate of compliance. A certificate of compliance shall be required from a manufacturer in order to be listed as an approved source of supply in MIL-HDBK-103 (see 6.6 herein). The certificate of compliance submitted to DSCC-VA prior to listing as an approved source of supply shall affirm that the manufacturer's product meets the requirements of MIL-PRF-38535, appendix A and the requirements herein.

3.7 Certificate of conformance. A certificate of conformance as required in MIL-PRF-38535, appendix A shall be provided with each lot of microcircuits delivered to this drawing.

3.8 Notification of change. Notification of change to DSCC-VA shall be required in accordance with MIL-PRF-38535, appendix A.

3.9 Verification and review. DSCC, DSCC's agent, and the acquiring activity retain the option to review the manufacturer's facility and applicable required documentation. Offshore documentation shall be made available onshore at the option of the reviewer.

|   |                  |                            |                   |
|---|------------------|----------------------------|-------------------|
| <b>STANDARD<br/>MICROCIRCUIT DRAWING</b><br>DEFENSE SUPPLY CENTER COLUMBUS<br>COLUMBUS, OHIO 43216-5000 | SIZE<br><b>A</b> |                            | <b>5962-87673</b> |
|   |                  | REVISION LEVEL<br><b>B</b> | SHEET<br><b>4</b> |

TABLE I. Electrical performance characteristics.

| Test                               | Symbol               | Conditions <sup>1/</sup><br>-55°C ≤ T <sub>A</sub> ≤ +125°C<br>unless otherwise specified                                     | Group A<br>subgroups | Device<br>type | Limits |      | Unit |
|------------------------------------|----------------------|---|----------------------|----------------|--------|------|------|
|                                    |                      |   |                      |                | Min    | Max  |      |
| Resistance (on)<br>drain-to-source | R <sub>DS</sub>      | V <sub>D</sub> = -7.5 V, I <sub>S</sub> = -10 mA,<br>V <sub>IN</sub> = 0.8 V  | 1,3                  | 01             | 2      | 10   | Ω    |
|                                    |                      |   | 2                    |                | 2      | 20   |      |
| Source leakage<br>current (off)    | I <sub>S(OFF)</sub>  | +V <sub>CC</sub> = 10 V, -V <sub>CC</sub> = -20 V,<br>V <sub>D</sub> = -10 V, V <sub>S</sub> = 10 V,<br>V <sub>IN</sub> = 2 V | 1                    | 01             | -10.0  | 10.0 | nA   |
|                                    |                      |   | 2,3                  |                | -1000  | 1000 |      |
|                                    |                      | V <sub>D</sub> = -7.5 V, V <sub>S</sub> = 7.5 V,<br>V <sub>IN</sub> = 2 V   | 1                    |                | -10.0  | 10.0 |      |
|                                    |                      |   | 2,3                  |                | -1000  | 1000 |      |
| Drain leakage<br>current (off)     | I <sub>D(OFF)</sub>  | V <sub>D</sub> = 7.5 V, V <sub>S</sub> = -7.5 V,<br>V <sub>IN</sub> = 2 V   | 1                    | 01             | -10.0  | 10.0 | nA   |
|                                    |                      |   | 2,3                  |                | -1000  | 1000 |      |
|                                    |                      | +V <sub>CC</sub> = 10 V, -V <sub>CC</sub> = -20 V,<br>V <sub>D</sub> = 10 V, V <sub>S</sub> = -10 V,<br>V <sub>IN</sub> = 2 V | 1                    |                | -10.0  | 10.0 |      |
|                                    |                      |   | 2,3                  |                | -1000  | 1000 |      |
| Channel leakage<br>current (on)    | I <sub>D(ON)</sub> + | V <sub>S</sub> = V <sub>D</sub> = -7.5 V,<br>V <sub>IN</sub> = 0.8 V  | 1                    | 01             | -2.0   | 2.0  | nA   |
|                                    | I <sub>S(ON)</sub>   |   | 2,3                  |                | -200   | 200  |      |
| Low level input<br>current         | I <sub>IL</sub>      | V <sub>IN</sub> under test = 0 V,<br>all other V <sub>IN</sub> = 5 V  | 1,2,3                | 01             | -250   | 10.0 | μA   |
| High level input<br>current        | I <sub>IH</sub>      | V <sub>IN</sub> under test = 5 V,<br>all other V <sub>IN</sub> = 0 V  | 1                    | 01             | -10.0  | 10.0 | μA   |
|                                    |                      |   | 2,3                  |                | -20    | 20   |      |

See footnotes at end of table.

|   |                  |                            |                   |
|---|------------------|----------------------------|-------------------|
| <b>STANDARD<br/>MICROCIRCUIT DRAWING</b><br>DEFENSE SUPPLY CENTER COLUMBUS<br>COLUMBUS, OHIO 43216-5000 | SIZE<br><b>A</b> |                            | <b>5962-87673</b> |
|   |                  | REVISION LEVEL<br><b>B</b> | SHEET<br><b>5</b> |

TABLE I. Electrical performance characteristics – Continued.

| Test                     | Symbol           | Conditions <sup>1/</sup><br>-55°C ≤ T <sub>A</sub> ≤ +125°C<br>unless otherwise specified | Group A<br>subgroups | Device<br>type | Limits |     | Unit |
|--------------------------|------------------|---|----------------------|----------------|--------|-----|------|
|                          |                  |   |                      |                | Min    | Max |      |
| Positive supply current  | +I <sub>CC</sub> | V <sub>IN</sub> = 0 V   | 1                    | 01             |        | 1.5 | mA   |
|                          |                  |   | 2                    |                |        | 1.5 |      |
|                          |                  |   | 3                    |                |        | 2.5 |      |
|                          |                  | V <sub>IN</sub> = 5 V   | 1                    |                |        | 1.5 |      |
|                          |                  |   | 2                    |                |        | 1.5 |      |
|                          |                  |   | 3                    |                |        | 2.5 |      |
| Negative supply current  | -I <sub>CC</sub> | V <sub>IN</sub> = 5 V   | 1                    | 01             | -5.0   |     | mA   |
|                          |                  |   | 2                    |                | -5.0   |     |      |
|                          |                  |   | 3                    |                | -8.0   |     |      |
|                          |                  | V <sub>IN</sub> = 0 V   | 1                    |                | -5.0   |     |      |
|                          |                  |   | 2                    |                | -5.0   |     |      |
|                          |                  |   | 3                    |                | -8.0   |     |      |
| Logic supply current     | I <sub>L</sub>   | V <sub>IN</sub> = 0 V and V <sub>IN</sub> = 5 V   | 1                    | 01             |        | 4.5 | mA   |
|                          |                  |   | 2                    |                |        | 4.5 |      |
|                          |                  |   | 3                    |                |        | 7.5 |      |
| Reference supply current | I <sub>R</sub>   | V <sub>IN</sub> = 0 V and V <sub>IN</sub> = 5 V   | 1                    | 01             | -2.0   |     | mA   |
|                          |                  |   | 2                    |                | -2.0   |     |      |
|                          |                  |   | 3                    |                | -2.5   |     |      |

See footnotes at end of table.

|   |                  |                            |                   |
|---|------------------|----------------------------|-------------------|
| <b>STANDARD<br/>MICROCIRCUIT DRAWING</b><br>DEFENSE SUPPLY CENTER COLUMBUS<br>COLUMBUS, OHIO 43216-5000 | SIZE<br><b>A</b> |                            | <b>5962-87673</b> |
|   |                  | REVISION LEVEL<br><b>B</b> | SHEET<br><b>6</b> |

TABLE I. Electrical performance characteristics – Continued.

| Test             | Symbol           | Conditions <u>1/</u><br>-55°C ≤ T <sub>A</sub> ≤ +125°C<br>unless otherwise specified | Group A<br>subgroups | Device<br>type | Limits |     | Unit |
|------------------|------------------|---|----------------------|----------------|--------|-----|------|
|                  |                  |   |                      |                | Min    | Max |      |
| Functional tests |                  | See 4.3.1c  | 7                    | 01             |        |     |      |
| Turn on time     | t <sub>ON</sub>  | See figure 4  | 9                    | 01             |        | 400 | ns   |
|                  |                  |   | 10 <u>2/</u>         |                |        | 600 |      |
|                  |                  |   | 11 <u>2/</u>         |                |        | 400 |      |
| Turn off time    | t <sub>OFF</sub> | See figure 4  | 9                    | 01             |        | 250 | ns   |
|                  |                  |   | 10,11 <u>2/</u>      |                |        | 350 |      |

1/ Unless otherwise specified, +V<sub>CC</sub> = +15 V, -V<sub>CC</sub> = -15 V, V<sub>L</sub> = 5 V.

2/ If not tested, shall be guaranteed to the limits specified in table I herein.

4. QUALITY ASSURANCE PROVISIONS

4.1 Sampling and inspection. Sampling and inspection procedures shall be in accordance with MIL-PRF-38535, appendix A.

4.2 Screening. Screening shall be in accordance with method 5004 of MIL-STD-883, and shall be conducted on all devices prior to quality conformance inspection. The following additional criteria shall apply:

a. Burn-in test, method 1015 of MIL-STD-883.

(1) Test condition A or C. The test circuit shall be maintained by the manufacturer under document revision level control and shall be made available to the preparing or acquiring activity upon request. The test circuit shall specify the inputs, outputs, biases, and power dissipation, as applicable, in accordance with the intent specified in test method 1015 of MIL-STD-883.

(2) T<sub>A</sub> = +125°C, minimum.

b. Interim and final electrical test parameters shall be as specified in table II herein, except interim electrical parameter tests prior to burn-in are optional at the discretion of the manufacturer.

|   |                  |                            |                   |
|---|------------------|----------------------------|-------------------|
| <b>STANDARD<br/>MICROCIRCUIT DRAWING</b><br>DEFENSE SUPPLY CENTER COLUMBUS<br>COLUMBUS, OHIO 43216-5000 | SIZE<br><b>A</b> |                            | <b>5962-87673</b> |
|   |                  | REVISION LEVEL<br><b>B</b> | SHEET<br><b>7</b> |

|                 |                  |                  |                  |
|-----------------|------------------|------------------|------------------|
| Device type     | 01               |                  |                  |
| Case outlines   | A and X          | C                | I                |
| Terminal number | Terminal symbol  |                  |                  |
| 1               | S <sub>1</sub>   | S <sub>1</sub>   | S <sub>1</sub>   |
| 2               | D <sub>1</sub>   | D <sub>1</sub>   | D <sub>1</sub>   |
| 3               | NC               | NC               | IN <sub>1</sub>  |
| 4               | NC               | NC               | +V <sub>CC</sub> |
| 5               | IN <sub>1</sub>  | IN <sub>1</sub>  | V <sub>L</sub>   |
| 6               | +V <sub>CC</sub> | +V <sub>CC</sub> | V <sub>R</sub>   |
| 7               | V <sub>L</sub>   | V <sub>L</sub>   | -V <sub>CC</sub> |
| 8               | V <sub>R</sub>   | V <sub>R</sub>   | IN <sub>2</sub>  |
| 9               | -V <sub>CC</sub> | -V <sub>CC</sub> | D <sub>2</sub>   |
| 10              | IN <sub>2</sub>  | IN <sub>2</sub>  | S <sub>2</sub>   |
| 11              | NC               | NC               | ---              |
| 12              | NC               | NC               | ---              |
| 13              | D <sub>2</sub>   | D <sub>2</sub>   | ---              |
| 14              | S <sub>2</sub>   | S <sub>2</sub>   | ---              |

NC = No connection

FIGURE 1. Terminal connections.

|       |        |
|-------|--------|
| LOGIC | SWITCH |
| 0     | ON     |
| 1     | OFF    |

Logic "0" ≤ 0.8 V

Logic "1" ≥ 2.0 V

FIGURE 2. Truth table.

|   |                  |                            |                   |
|---|------------------|----------------------------|-------------------|
| <b>STANDARD<br/>MICROCIRCUIT DRAWING</b><br>DEFENSE SUPPLY CENTER COLUMBUS<br>COLUMBUS, OHIO 43216-5000 | SIZE<br><b>A</b> |                            | <b>5962-87673</b> |
|   |                  | REVISION LEVEL<br><b>B</b> | SHEET<br><b>8</b> |



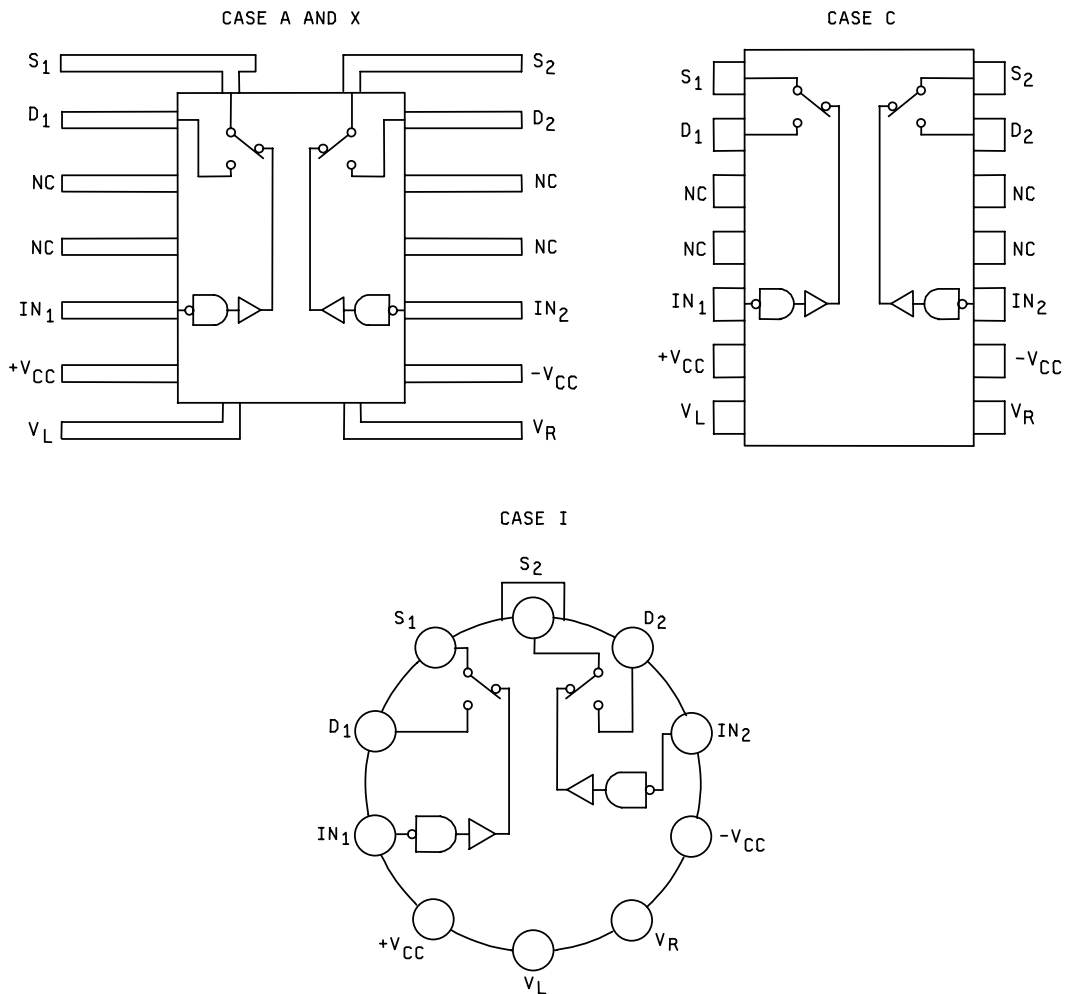

FIGURE 3. Logic diagram.

**STANDARD  
MICROCIRCUIT DRAWING**  
DEFENSE SUPPLY CENTER COLUMBUS  
COLUMBUS, OHIO 43216-5000

SIZE  
**A**

**5962-87673**

REVISION LEVEL  
**B**

SHEET  
**9**

LOGIC INPUT FOR OFF TO ON CONDITION

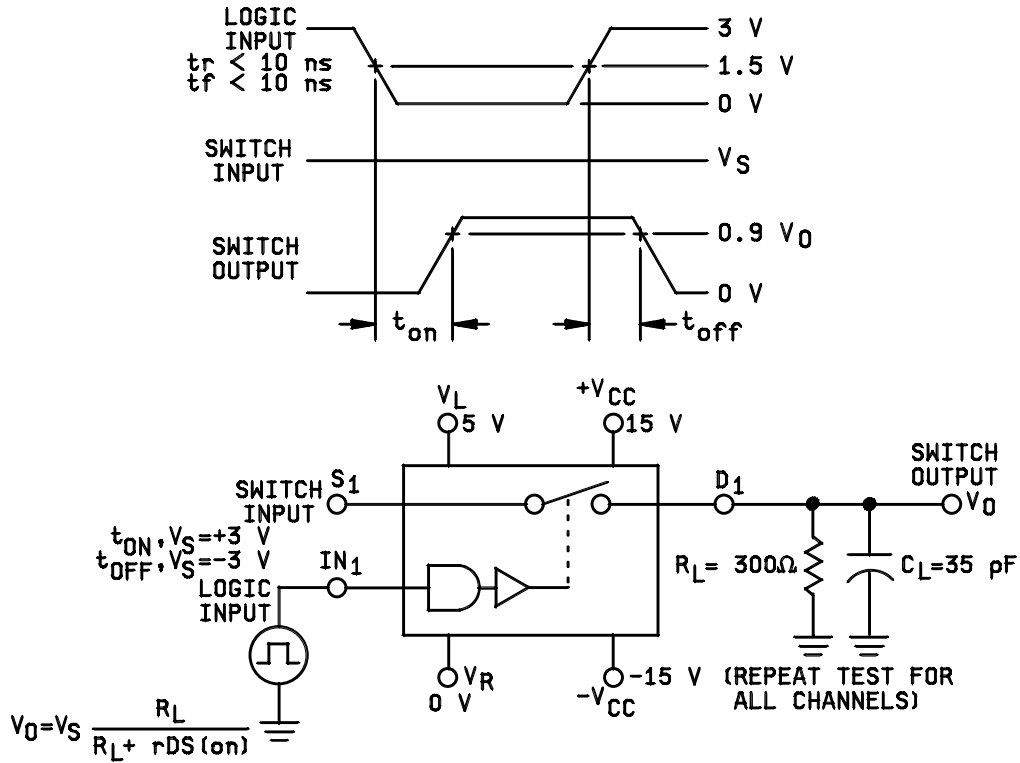

$V_O$  is the steady state output with the switch on. Feedthrough via switch capacitance may result in spikes at the leading and trailing edge of the output waveform. Switch output waveform shown for  $V_S = \text{constant}$  with logic input waveform as shown. Note that  $V_S$  may be + or - as per switching time test circuit.

FIGURE 4. AC switching diagram.

|   |                  |                            |                    |
|---|------------------|----------------------------|--------------------|
| <b>STANDARD<br/>MICROCIRCUIT DRAWING</b><br>DEFENSE SUPPLY CENTER COLUMBUS<br>COLUMBUS, OHIO 43216-5000 | SIZE<br><b>A</b> |                            | <b>5962-87673</b>  |
|   |                  | REVISION LEVEL<br><b>B</b> | SHEET<br><b>10</b> |

TABLE II. Electrical test requirements.

| MIL-STD-883 test requirements                                      | Subgroups<br>(in accordance with<br>MIL-STD-883, method 5005,<br>table I) |
|--|---|
| Interim electrical parameters<br>(method 5004)                     | 1   |
| Final electrical test parameters<br>(method 5004)                  | 1*,2,3,7,9  |
| Group A test requirements<br>(method 5005)                         | 1,2,3,7,9,10**,11**   |
| Groups C and D end-point<br>electrical parameters<br>(method 5005) | 1   |

\* PDA applies to subgroup 1.

\*\* Subgroups 10 and 11, if not tested, shall be guaranteed to the limits as specified in table I.

4.3 Quality conformance inspection. Quality conformance inspection shall be in accordance with method 5005 of MIL-STD-883 including groups A, B, C, and D inspections. The following additional criteria shall apply.

4.3.1 Group A inspection.

- a. Tests shall be as specified in table II herein.
- b. Subgroups 4, 5, 6, and 8 in table I, method 5005 of MIL-STD-883 shall be omitted.
- c. Subgroup 7 shall include verification of the truth table.

4.3.2 Groups C and D inspections.

- a. End-point electrical parameters shall be as specified in table II herein.
- b. Steady-state life test conditions, method 1005 of MIL-STD-883.
  - (1) Test condition A or C. The test circuit shall be maintained by the manufacturer under document revision level control and shall be made available to the preparing or acquiring activity upon request. The test circuit shall specify the inputs, outputs, biases, and power dissipation, as applicable, in accordance with the intent specified in test method 1005 of MIL-STD-883.
  - (2)  $T_A = +125^\circ\text{C}$ , minimum.
  - (3) Test duration: 1,000 hours, except as permitted by method 1005 of MIL-STD-883.

5. PACKAGING

5.1 Packaging requirements. The requirements for packaging shall be in accordance with MIL-PRF-38535, appendix A.

|   |                  |                            |                    |
|---|------------------|----------------------------|--------------------|
| <b>STANDARD<br/>MICROCIRCUIT DRAWING</b><br>DEFENSE SUPPLY CENTER COLUMBUS<br>COLUMBUS, OHIO 43216-5000 | SIZE<br><b>A</b> |                            | <b>5962-87673</b>  |
|   |                  | REVISION LEVEL<br><b>B</b> | SHEET<br><b>11</b> |

6. NOTES

6.1 Intended use. Microcircuits conforming to this drawing are intended for use for Government microcircuit applications (original equipment), design applications, and logistics purposes.

6.2 Replaceability. Microcircuits covered by this drawing will replace the same generic device covered by a contractor-prepared specification or drawing.

6.3 Configuration control of SMD's. All proposed changes to existing SMD's will be coordinated with the users of record for the individual documents. This coordination will be accomplished using DD Form 1692, Engineering Change Proposal.

6.4 Record of users. Military and industrial users shall inform Defense Supply Center Columbus when a system application requires configuration control and the applicable SMD. DSCC will maintain a record of users and this list will be used for coordination and distribution of changes to the drawings. Users of drawings covering microelectronics devices (FSC 5962) should contact DSCC-VA, telephone (614) 692-0544.

6.5 Comments. Comments on this drawing should be directed to DSCC-VA, Columbus, Ohio 43216-5000, or telephone (614) 692-0547.

6.6 Approved sources of supply. Approved sources of supply are listed in MIL-HDBK-103. The vendors listed in MIL-HDBK-103 have agreed to this drawing and a certificate of compliance (see 3.6 herein) has been submitted to and accepted by DSCC-VA.

|   |                  |                            |                    |
|---|------------------|----------------------------|--------------------|
| <b>STANDARD<br/>MICROCIRCUIT DRAWING</b><br>DEFENSE SUPPLY CENTER COLUMBUS<br>COLUMBUS, OHIO 43216-5000 | SIZE<br><b>A</b> |                            | <b>5962-87673</b>  |
|   |                  | REVISION LEVEL<br><b>B</b> | SHEET<br><b>12</b> |

STANDARD MICROCIRCUIT DRAWING BULLETIN

DATE: 02-09-23

Approved sources of supply for SMD 5962-87673 are listed below for immediate acquisition information only and shall be added to MIL-HDBK-103 and QML-38535 during the next revision. MIL-HDBK-103 and QML-38535 will be revised to include the addition or deletion of sources. The vendors listed below have agreed to this drawing and a certificate of compliance has been submitted to and accepted by DSCC-VA. This bulletin is superseded by the next dated revision of MIL-HDBK-103 and QML-38535.

| Standard microcircuit drawing<br>PIN <u>1/</u> | Vendor CAGE<br>number | Vendor similar<br>PIN <u>2/</u> |
|--|-----------------------|---------------------------------|
| 5962-8767301AA                                 | <u>3/</u>             | DG180AL/883                     |
| 5962-8767301CA                                 | 17856                 | DG180AP/883                     |
| 5962-8767301IA                                 | 17856                 | DG180AA/883                     |
| 5962-8767301XA                                 | 17856                 | DG180AL/883                     |

- 1/ The lead finish shown for each PIN representing a hermetic package is the most readily available from the manufacturer listed for that part. If the desired lead finish is not listed contact the vendor to determine its availability.
- 2/ Caution. Do not use this number for item acquisition. Items acquired to this number may not satisfy the performance requirements of this drawing.
- 3/ Not available from an approved source of supply.

Vendor CAGE  
number

17856

Vendor name  
and address

Siliconix, Incorporated  
2201 Laurelwood Road  
Santa Clara, CA 95054-1516

The information contained herein is disseminated for convenience only and the Government assumes no liability whatsoever for any inaccuracies in the information bulletin.