

# Lighting Transformer (LT Series)

The compact LT Transformer components offer Safety Extra Low Voltage (SELV) outputs designed for industries and OEM installations of landscape, track, recessed and LED lighting, as well as security systems, in the commercial, consumer and industrial sectors. When SELV outputs are required to operate control equipment and other electronic devices, a step-down transformer is needed to convert from 120V or 277V to 12V. Offering a safer work environment, the SELV isolation provided by Signal's LT Transformer Series eliminates potential shock hazards. The LT277-50-12 is ideal for 480V, 3 phase 4-wire systems, where line voltage to neutral is equal to single phase 277V 50/60 Hz. The LT120-50-12 is designed for single phase 120V 50/60 Hz supplies.



## Features

- UL recognized to North American Harmonized standards: UL5085-1-2 and CSA C22.2 No. 66
- Easy to mount and can be hardwired via standard 1/2" conduit hardware and a straight box connection
- Corrosion-resistant surface coating that is environmentally resilient
- Insulation: Class B (130°C) UL 1446
- Lead Wire Connections: 18AWG UL 1015
- Rugged construction at a reasonable price

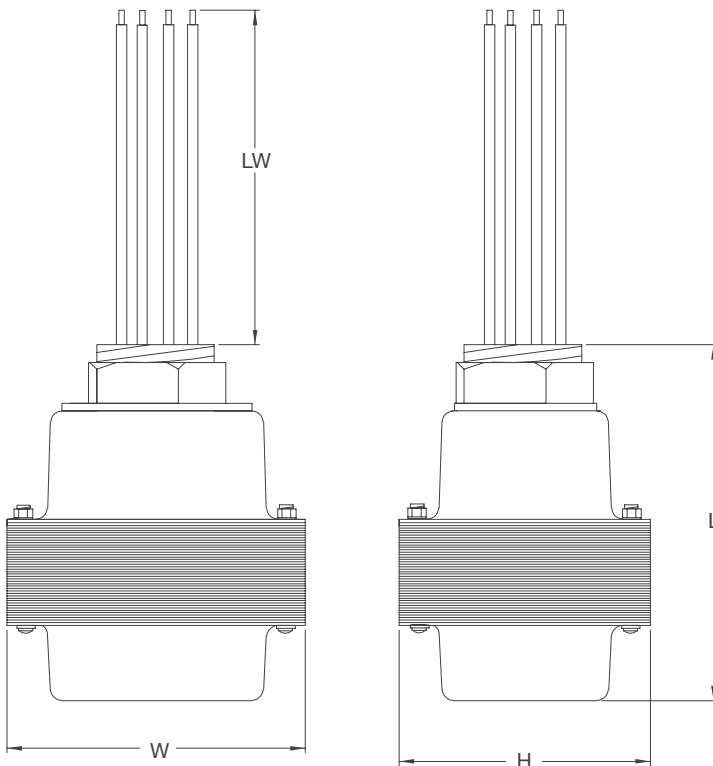

## Applications & Industries

- OEM installations of landscape, track, recessed and LED lighting
- Security systems in the commercial, consumer and industrial sectors

Part No.	VA	Primary Rating	Secondary Rating
LT277-50-12	50	277V, 50/60 Hz	12V @ 4.17 A
LT120-50-12	50	120V, 50/60 Hz	12V @ 4.17 A

VA Size	W	H	L	LW	Weight lbs. (kg)
	Inches (mm)				
50	2.60 (66)	2.18 (55.3)	3.10 (78.7)	6.0 (152)	1.7 (.77)

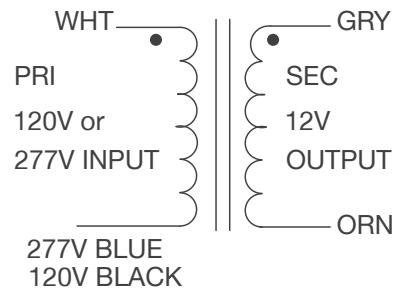

Custom versions available upon request.

© 2020 Signal Transformer Inc. Specifications subject to change without notice. 04.20



128 Atlantic Avenue, Lynbrook, NY 11563  
 Toll Free 866-239-5777 | Tel 516-239-5777 | Fax 516-239-7208  
 sales@signaltransformer.com | techhelp@signaltransformer.com



[belfuse.com/signal](http://belfuse.com/signal)