

LOC	DIST	REVISIONS				
CM	0	REV	DESCRIPTION	DATE	BY	APPV
		C	REVISED PER ECO-12-016930	05OCT12	KH	SM
		C1	ECR-12-016748	30AUG13	M.T	D.Z

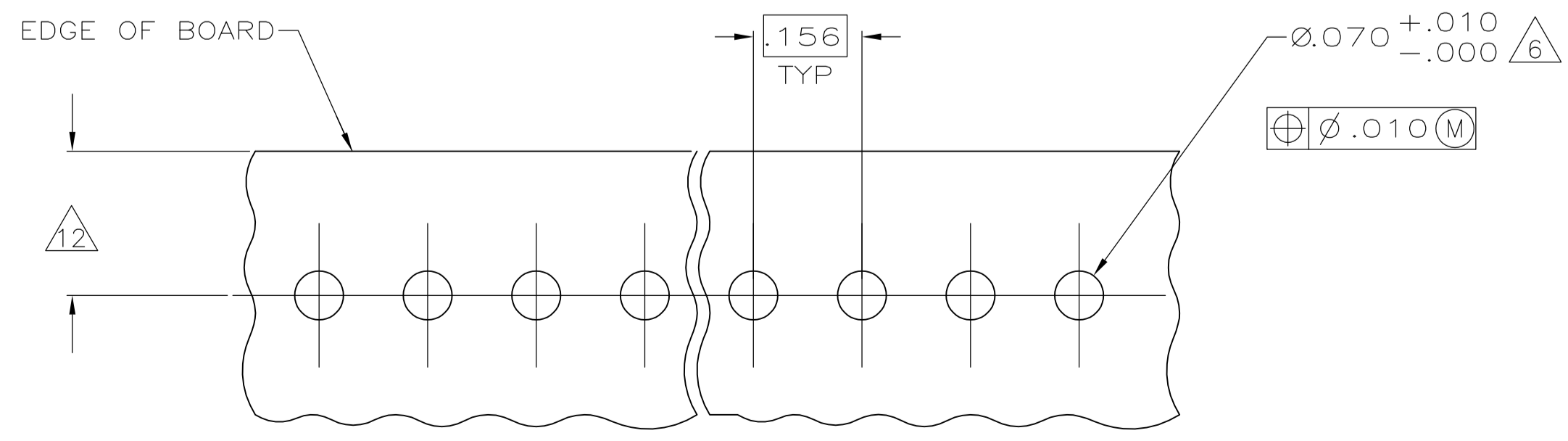
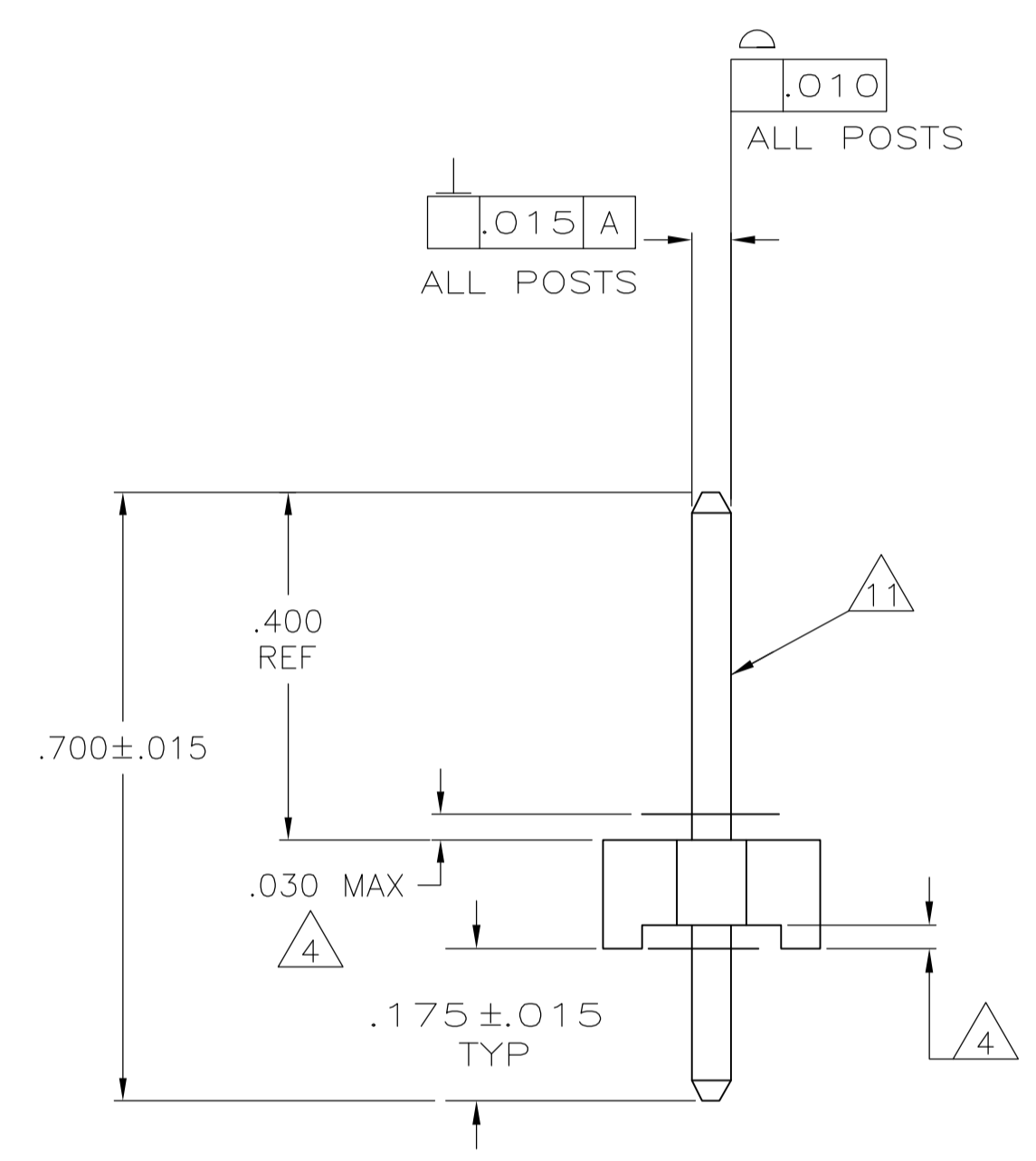
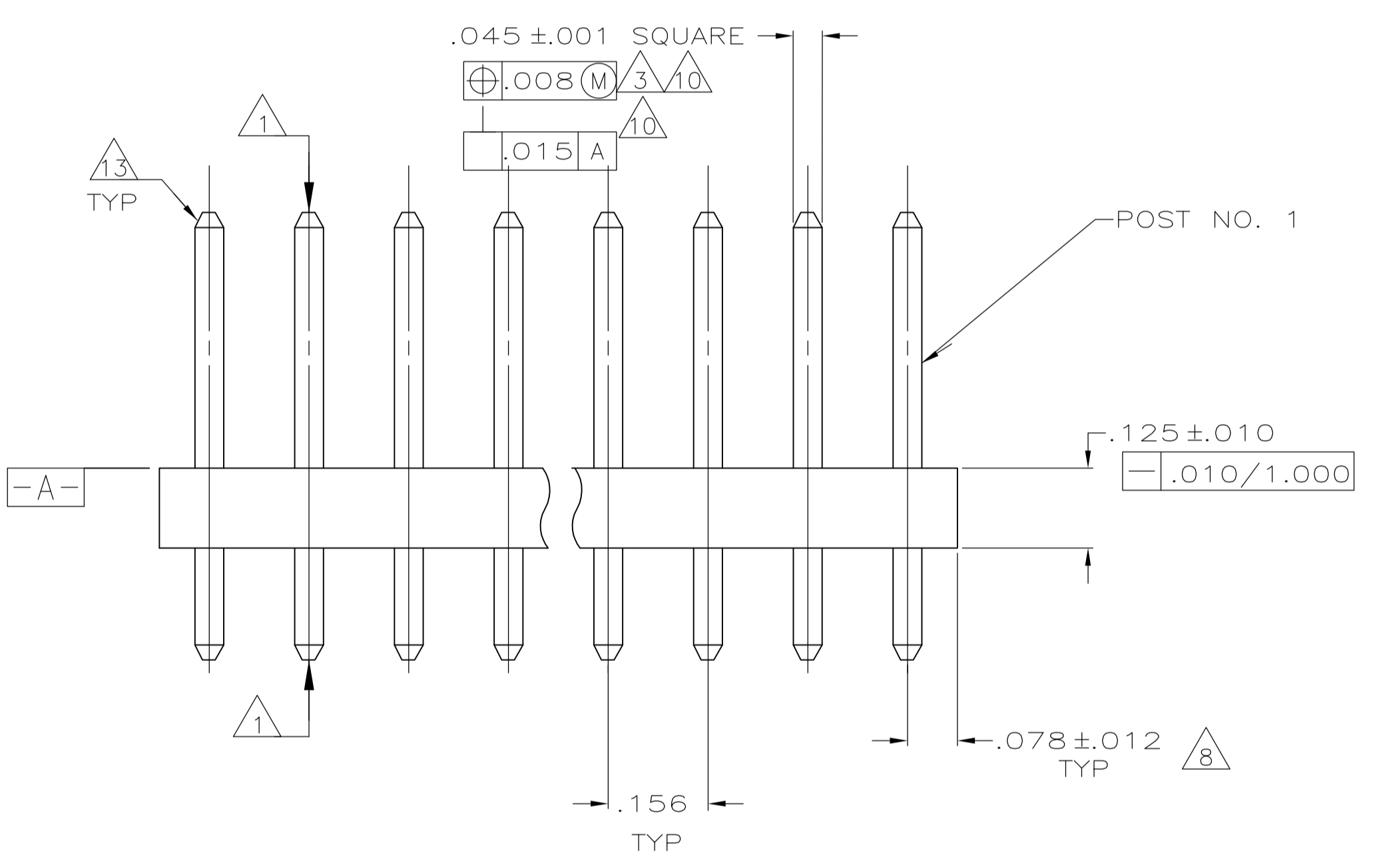
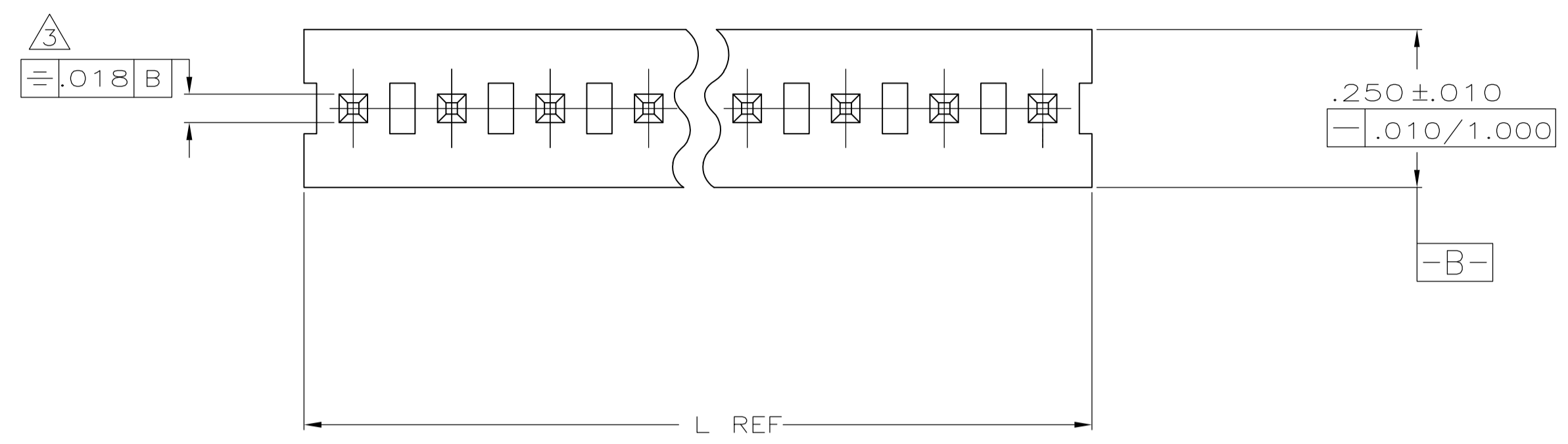

(C1) RECOMMENDED MOUNTING HOLE PATTERN FOR .109±0.016 THICK P.C. BOARD

- 1 POST TO WITHSTAND 13 NEWTONS (3LBS.) MIN. AXIAL FORCE IN BOTH DIRECTIONS SHOWN WITHOUT DISLODGING.
- 2 TOLERANCES APPLY TO SOLDER SIDE OF BOARD.
- 3 MEASURED AT SURFACE -A-
- 4 PLASTIC FLASH PERMITTED IN THIS AREA.
- 5 PARTS COMPLY WITH AMP SOLDERABILITY SPEC. NO. 109-11-2.
- 6 ONE HOLE MAY BE UNDERSIZED (.065/.060 DIA.) FOR ASSEMBLY RETENTION DURING WAVE SOLDERING.
- 7 MATERIAL: HEADER-THERMOPLASTIC POLYESTER GLASS-FILLED 94V-0(NATURAL) POST-COPPER ALLOY (TIN PLATED)
- 8 COORDINATE DIMENSION APPLIES FROM CENTER OF ACTUAL FEATURE.
- 9 PLASTIC BURRS CAUSED BY CUT-OFF TOOLING ARE PERMITTED WITHIN THE MAXIMUM TOLERANCE ENVELOPE.
- 10 POST TO BE MEASURED WHEN STRIP IS HELD FLAT.
- 11 POST MUST WITHSTAND TWO 90° BENDS AGAINST EXTRUSION WITHOUT BREAKING.
- 12 DIMENSION SHOULD BE .140 MIN WHEN MATING WITH A MTA-156 CONNECTOR ASSEMBLY OR A SL-156 CONNECTOR ASSEMBLY.
- 13 PIN BURR OF .005 MAX. VERTICAL AND .003 MAX. HORIZONTAL PERMITTED AT POST TIPS ON BOTH ENDS.

IN	MM	IN	MM
.063	1.60	-	-
.060	1.52	-	-
.045	1.14	1.000	25.40
.030	0.76	.750	19.05
.018	0.46	.450	11.43
.015	0.38	.250	6.35
.012	0.30	.175	4.45
.010	0.25	.156	3.96
.008	0.20	.140	3.56
.005	0.13	.125	3.18
.003	0.08	.078	1.98
.001	0.03	.070	1.78
.000	0.00	.065	1.65
IN	MM	IN	MM

CONVERSION TABLE

IN	MM	NUMBER OF POSITIONS	PART NUMBER
3.744	95.10	24	2-644749-4
3.588	91.14	23	2-644749-3
3.432	87.17	22	2-644749-2
3.276	83.21	21	2-644749-1
3.120	79.25	20	2-644749-0
2.964	75.29	19	1-644749-9
2.808	71.32	18	1-644749-8
2.652	67.36	17	1-644749-7
2.496	63.40	16	1-644749-6
2.340	59.44	15	1-644749-5
2.184	55.47	14	1-644749-4
2.028	51.51	13	1-644749-3
1.872	47.55	12	1-644749-2
1.716	43.59	11	1-644749-1
1.560	39.62	10	1-644749-0
1.404	35.66	9	644749-9
1.248	31.70	8	644749-8
1.092	27.74	7	644749-7
.936	23.77	6	644749-6
.780	19.81	5	644749-5
.624	15.85	4	644749-4
.468	11.89	3	644749-3
.312	7.92	2	644749-2
IN	MM	NUMBER OF POSITIONS	PART NUMBER

THIS DRAWING IS A CONTROLLED DOCUMENT.

DIN L. SMITH 4-19-94
 CHK R. SWING 4-19-94
 APVD D. CLARK 5-06-94
 NAME

MTA-156 HEADER ASSEMBLY, PLAIN, STRAIGHT, .045 SQUARE POST, TIN PLATED, SPECIAL

SIZE: A1
 CASE CODE: 00779
 DRAWING NO: 644749
 WEIGHT: -

CUSTOMER DRAWING SCALE: 5:1 SHEET: 1 of 1 REV: C1