

EM4100

Read Only Contactless Identification Device

Description

The EM4100 (previously named H4100) is a CMOS integrated circuit for use in electronic Read Only RF Transponders. The circuit is powered by an external coil placed in an electromagnetic field, and gets its master clock from the same field via one of the coil terminals. By turning on and off the modulation current, the chip will send back the 64 bits of information contained in a factory pre-programmed memory array.

The programming of the chip is performed by laser fusing of polysilicon links in order to store a unique code on each chip.

The EM4100 has several metal options which are used to define the code type and data rate. Data rates of 64, 32 and 16 periods of carrier frequency per data bit are available. Data can be coded as Manchester, Biphase or PSK.

Due to low power consumption of the logic core, no supply buffer capacitor is required. Only an external coil is needed to obtain the chip function. A parallel resonance capacitor of 74 pF is also integrated.

Features

- 64 bit memory array laser programmable
- Several options of data rate and coding available
- On chip resonance capacitor
- On chip supply buffer capacitor
- On chip voltage limiter
- Full wave rectifier on chip
- Large modulation depth due to a low impedance modulation device
- Operating frequency 100 - 150 kHz
- Very small chip size convenient for implantation
- Very low power consumption

Applications

- Logistics automation
- Anticounterfeiting
- Access control
- Industrial transponder

Typical Operating Configuration

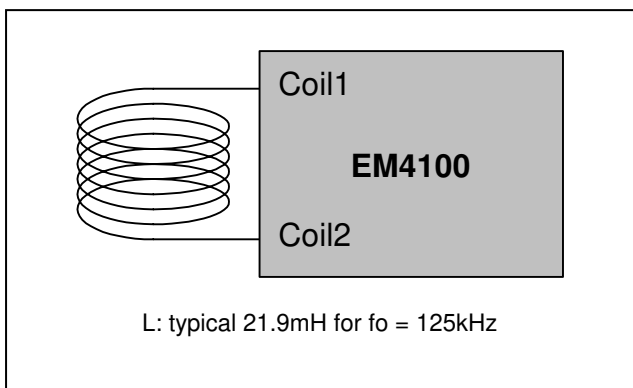

Fig. 1

Pin Assignment

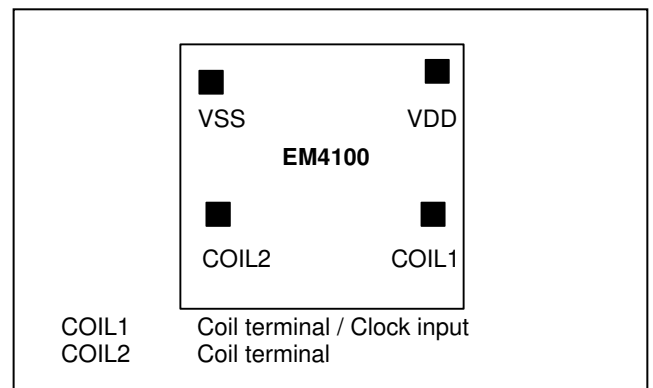

Fig. 2



Absolute Maximum Ratings

Parameter	Symbol	Conditions
Maximum DC Current forced on COIL1 & COIL2	I_{COIL}	$\pm 30\text{mA}$
Power Supply	V_{DD}	-0.3 to 7.5V
Storage Temp. Die form	T_{store}	-55 to +200°C
Storage Temp. PCB form	T_{store}	-55 to +125°C
Electrostatic discharge maximum to MIL-STD-883C method 3015	V_{ESD}	1000V

Stresses above these listed maximum ratings may cause permanent damage to the device. Exposure beyond specified operating conditions may affect device reliability or cause malfunction.

Operating Conditions

Parameter	Symbol	Min.	Typ.	Max.	Units
Operating Temp.	T_{op}	-40		+85	°C
Maximum Coil Current	I_{coil}			10	mA
AC Voltage on Coil	V_{coil}	3	14*		Vpp
Supply Frequency	f_{coil}	100		150	kHz

*) The AC Voltage on Coil is limited by the on chip voltage limitation circuitry. This is according to the parameter I_{coil} in the absolute maximum ratings.

Handling Procedures

This device has built-in protection against high static voltages or electric fields; however due to the unique properties of this device, anti-static precautions should be taken as for any other CMOS component.

System Principle

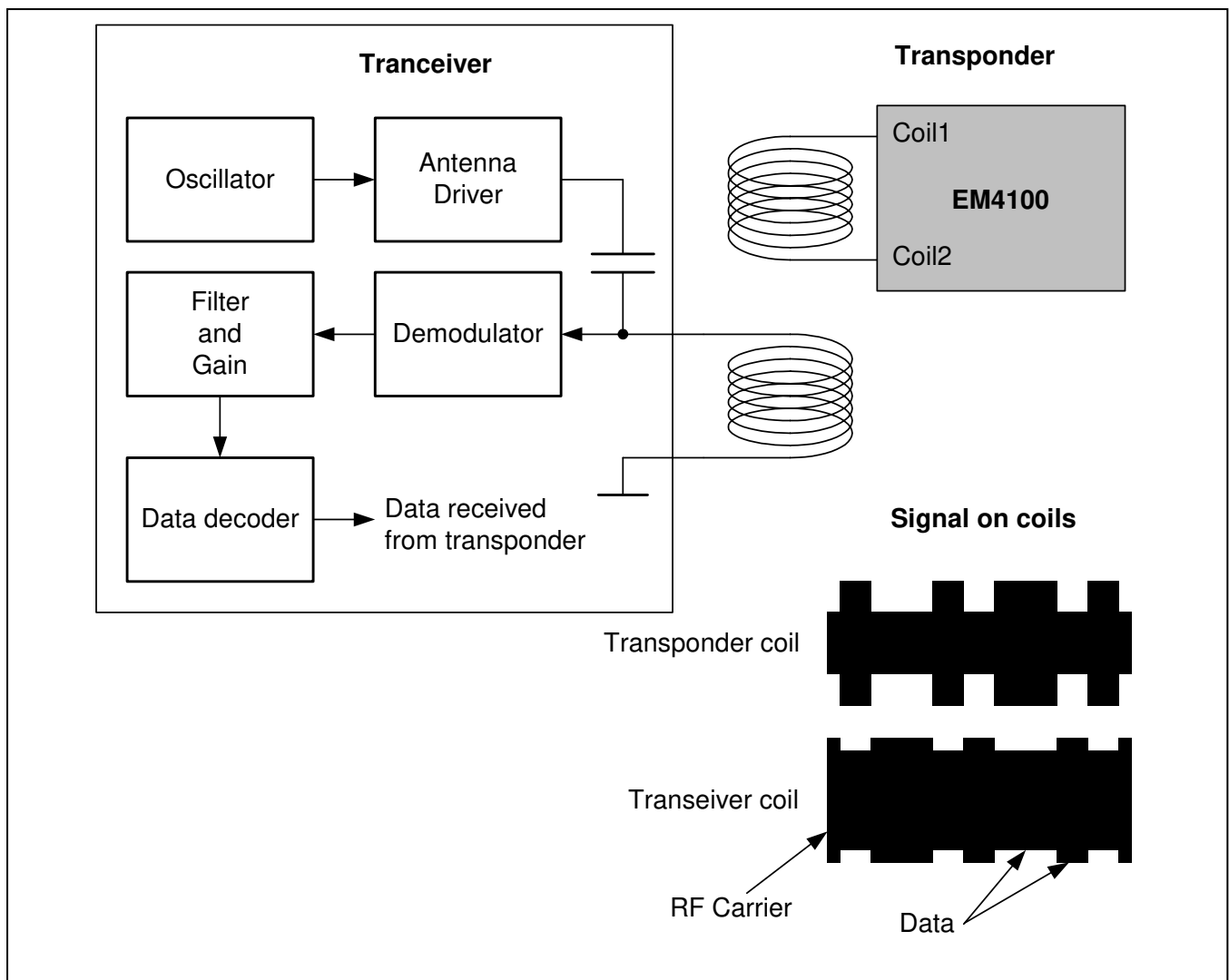

Fig. 3



Electrical Characteristics

$V_{DD} = 1.5V$, $V_{SS} = 0V$, $f_{C1} = 134kHz$ square wave, $T_a = 25^\circ C$

$V_{C1} = 1.0V$ with positive peak at V_{DD} and negative peak at $V_{DD} - 1V$ unless otherwise specified

Parameter	Symbol	Test Conditions	Min.	Typ.	Max.	Units
Supply Voltage	V_{DD}		1.5		1) 1.5	V
Rectified Supply Voltage	V_{DDREC}	$V_{COIL1} - V_{COIL2} = 2.8$ VDC Modulator switch = "ON"	1.5			V
Coil1 - Coil2 Capacitance	C_{res}	$V_{coil} = 100mV_{RMS}$ $f = 10kHz$		74 2)		pF
Power Supply Capacitor	C_{sup}			120		pF
Biphase & Manchester Versions						
Supply Current	I_{DD}			0.63	1.5	μA
C2 pad Modulator ON voltage drop	V_{ONC2}	$V_{DD} = 1.5V$ $I_{VDDC2} = 100\mu A$ with ref. to V_{DD}	0.9	1.1	1.3	V
		$V_{DD} = 5.0V$ $I_{VDDC2} = 1mA$ with ref. to V_{DD}	2.1	2.3	2.8	V
C1 pad Modulator ON voltage drop	V_{ONC1}	$V_{DD} = 5.0V$ $I_{VDDC1} = 1mA$ with ref. to V_{DD}	2.1	2.3	2.8	V
PSK Version						
Supply Current PSK	I_{DDPSK}			0.92	2	μA
C2 pad Modulator ON voltage drop	$V_{ONC2PSK}$	$V_{DD} = 1.5V$ $I_{VDDC2} = 100\mu A$ with ref. to V_{DD}	0.3	0.6	0.9	V

Note 1) The maximum voltage is defined by forcing 10mA on COIL1 - COIL2

Note 2) The tolerance of the resonant capacitor is $\pm 15\%$ over the whole production.

Optional reduced tolerance on request
On a wafer basis, the tolerance is $\pm 2\%$

Timing Characteristics

$V_{DD} = 1.5V$, $V_{SS} = 0V$, $f_{coil} = 134kHz$ square wave, $T_a = 25^\circ C$

$V_{C1} = 1.0V$ with positive peak at V_{DD} and negative peak at $V_{DD} - 1V$ unless otherwise specified

Timings are derived from the field frequency and are specified as a number of RF periods.

Parameter	Symbol	Test Conditions	Value	Units
Read Bit Period	T_{rdB}	depending on option	64, 32, 16	RF periods

Timing Waveforms

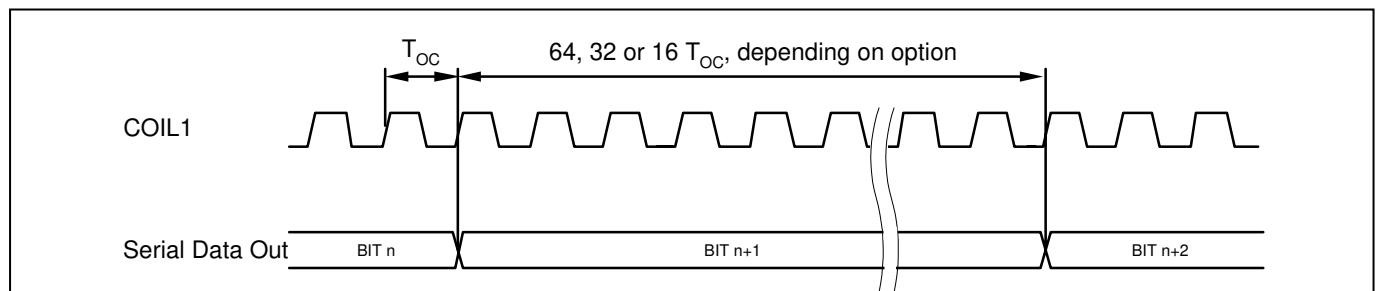

Fig. 4

Block Diagram

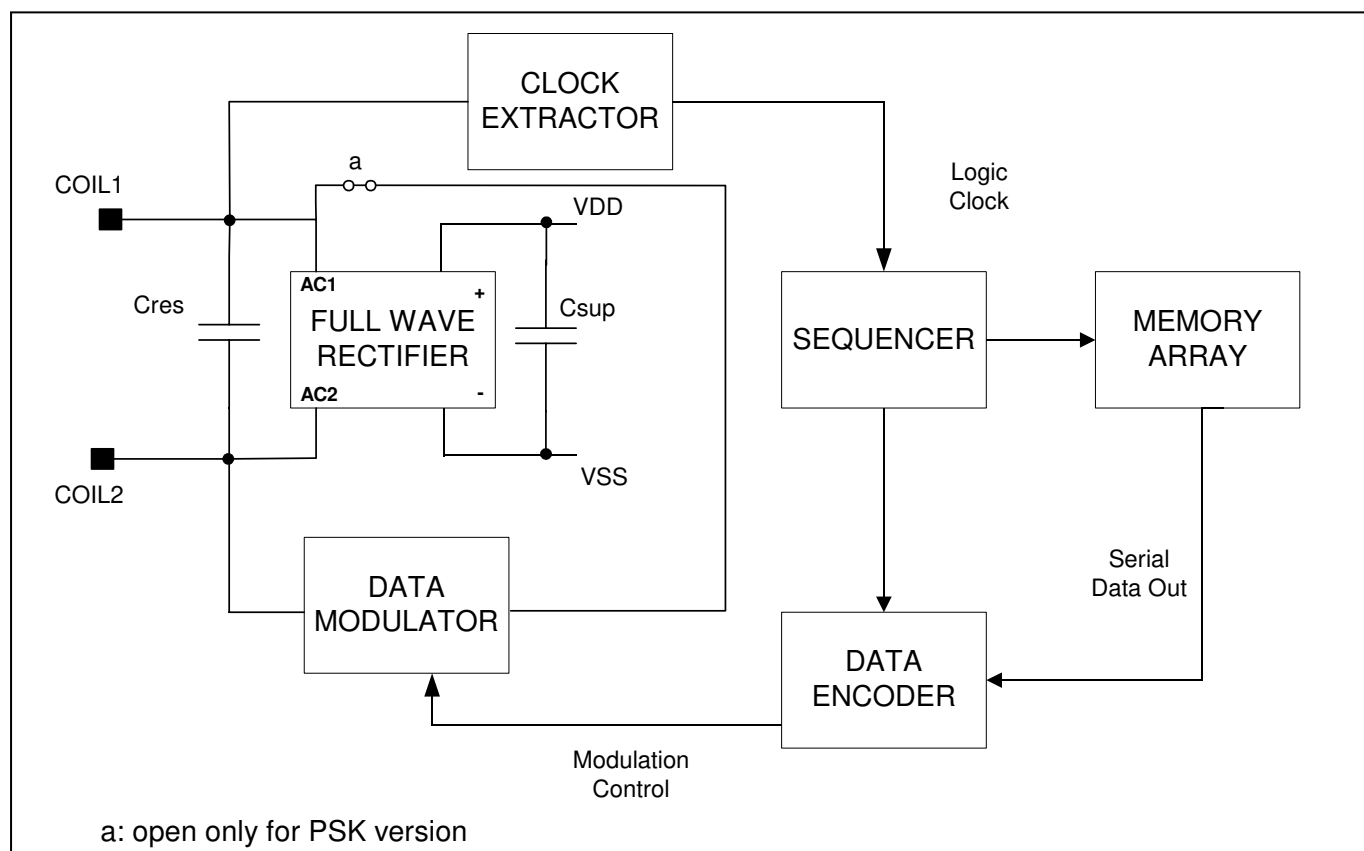

Fig. 5

Functional Description

General

The EM4100 is supplied by means of an electromagnetic field induced on the attached coil. The AC voltage is rectified in order to provide a DC internal supply voltage. When the last bit is sent, the chip will continue with the first bit until the power goes off.

Full Wave Rectifier

The AC input induced in the external coil by an incident magnetic field is rectified by a Graetz bridge. The bridge will limit the internal DC voltage to avoid malfunction in strong fields.

Clock Extractor

One of the coil terminals (COIL1) is used to generate the master clock for the logic function. The output of the clock extractor drives a sequencer.

Sequencer

The sequencer provides all necessary signals to address the memory array and to encode the serial data out.

Three mask programmed encoding versions of logic are available. These three encoding types are Manchester, biphase and PSK. The bit rate for the first and the second type can be 64 or 32 periods of the field frequency. For the PSK version, the bit rate is 16.

The sequencer receives its clock from the COIL1 clock extractor and generates every internal signal controlling the memory and the data encoder logic.

Data Modulator

The data modulator is controlled by the signal Modulation Control in order to induce a high current in the coil. In the PSK version, only COIL2 transistor drives this high current. In the other versions, both coil1 and coil2 transistors drive it to Vdd. This will affect the magnetic field according to the data stored in the memory array.

Resonance Capacitor

This capacitor can be trimmed in factory by 0.5pf steps to achieve the absolute value of 74pf typically. This option, which is on request, allows a smaller capacitor tolerance on the whole of the production.



Memory Array for Manchester & Bi-Phase encoding ICs

The EM4100 contains 64 bits divided in five groups of information. 9 bits are used for the header, 10 row parity bits (P0-P9), 4 column parity bits (PC0-PC3), 40 data bits (D00-D93), and 1 stop bit set to logic 0.

1	1	1	1	1	1	1	1	1	1	9 header bits
8 version bits or customer ID	D00	D01	D02	D03	P0	10 line parity bits				
	D10	D11	D12	D13	P1					
32 data bits	D20	D21	D22	D23	P2					
	D30	D31	D32	D33	P3					
	D40	D41	D42	D43	P4					
	D50	D51	D52	D53	P5					
	D60	D61	D62	D63	P6					
	D70	D71	D72	D73	P7					
	D80	D81	D82	D83	P8					
	D90	D91	D92	D93	P9					
	PC0	PC1	PC2	PC3	S0	4 column parity bits				

The header is composed of the 9 first bits which are all mask programmed to "1". Due to the data and parity organisation, this sequence cannot be reproduced in the data string. The header is followed by 10 groups of 4 data bits allowing 100 billion combinations and 1 even row parity bit. Then, the last group consists of 4 event column parity bits without row parity bit. S0 is a stop bit which is written to "0"

Bits D00 to D03 and bits D10 to D13 are customer specific identification. These 64 bits are outputted serially in order to control the modulator. When the 64 bits data string is outputted, the output sequence is repeated continuously until power goes off.

Memory Array for PSK encoding ICs

The PSK coded IC's are programmed with odd parity for P0 and P1 and always with a logic zero. The parity bits from P2 to P9 are even. The column parity PC0 to PC3 are calculated including the version bits and are even parity bits.

Code Description

Manchester

There is always a transition from ON to OFF or from OFF to ON in the middle of bit period. At the transition from logic bit "1" to logic bit "0" or logic bit "0" to logic bit "1" the phase change. Value high of data stream presented below modulator switch OFF, low represents switch ON (see Fig. 6).

Biphase Code

At the beginning of each bit, a transition will occur. A logic bit "1" will keep its state for the whole bit duration and a logic bit "0" will show a transition in the middle of the bit duration (see Fig. 7).

PSK Code

Modulation switch goes ON and OFF alternately every period of carrier frequency. When a phase shift occurs, a logical "0" is read from the memory. If no shift phase occurs after a data rate cycle, a logical "1" is read (see Fig. 8).

Manchester Code

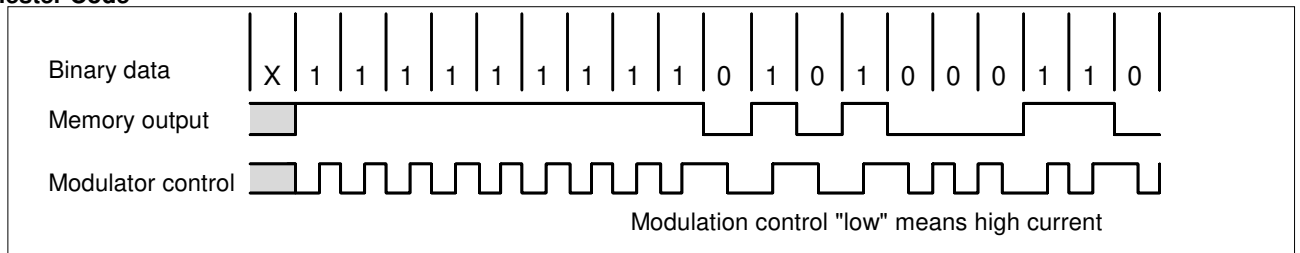

Fig. 6

Biphase Code

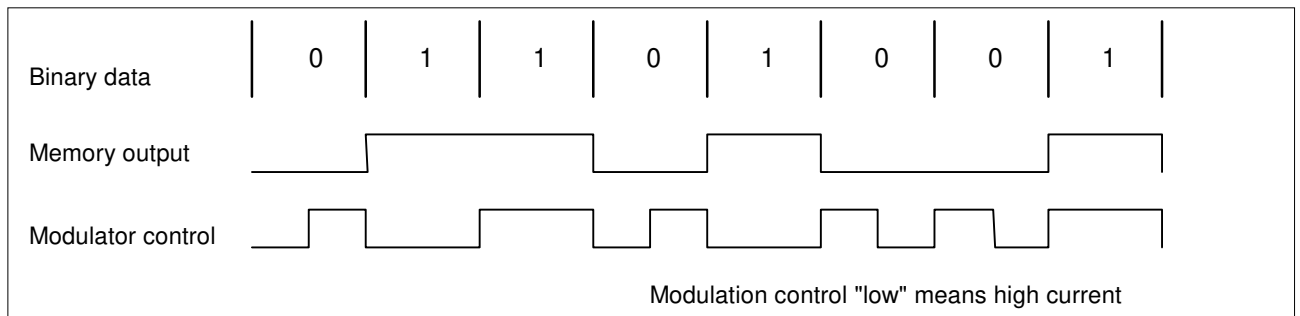

Fig. 7

PSK Code

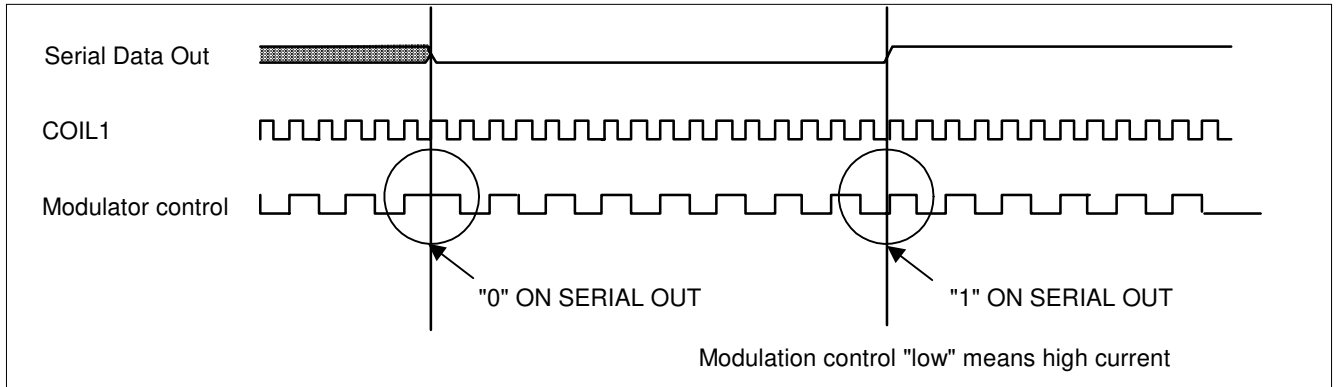

Fig. 8

Typical Performance Characteristics

Typical Capacitor Variation versus Temperature

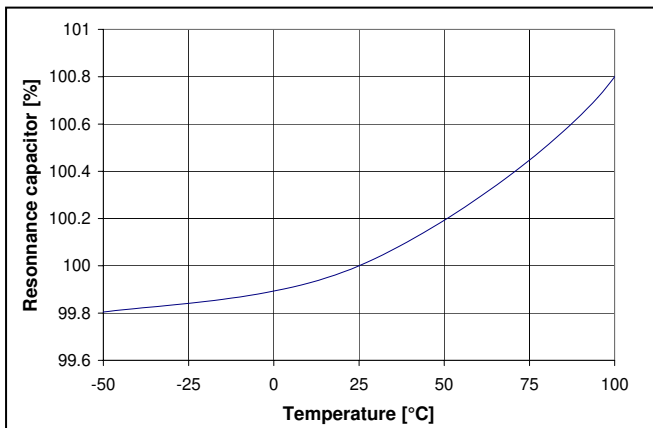

Fig. 9

Dynamic Consumption Versus temperature with Vdd-Vss=1.5V

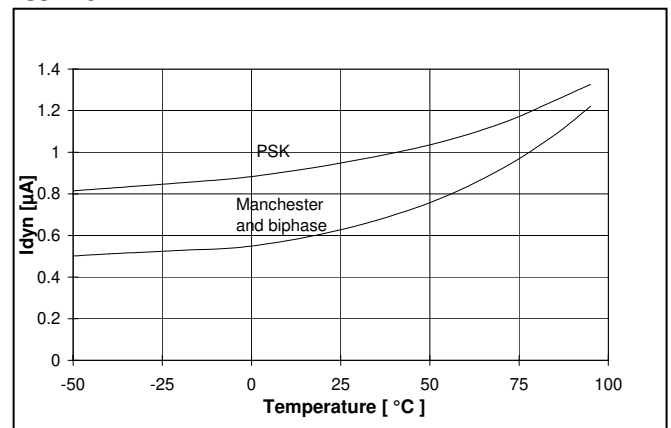

Fig. 10

L versus Resonance Frequency versus for a typical coil capacitance of 74 pf

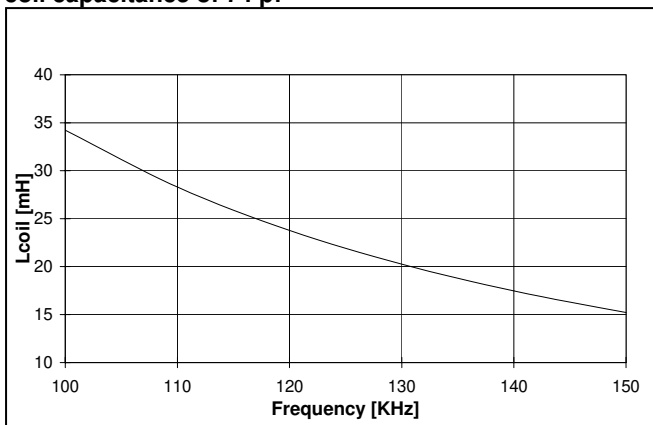

Fig. 11

Rectified Voltage versus temperature for Vcoil2-Vcoil1=2.8V

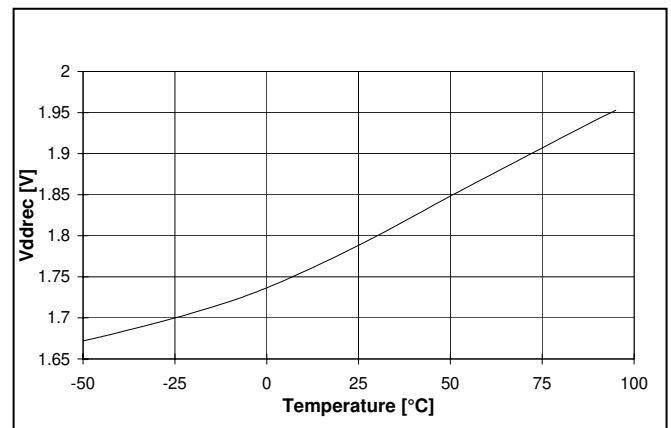

Fig. 12

CHIP Dimensions

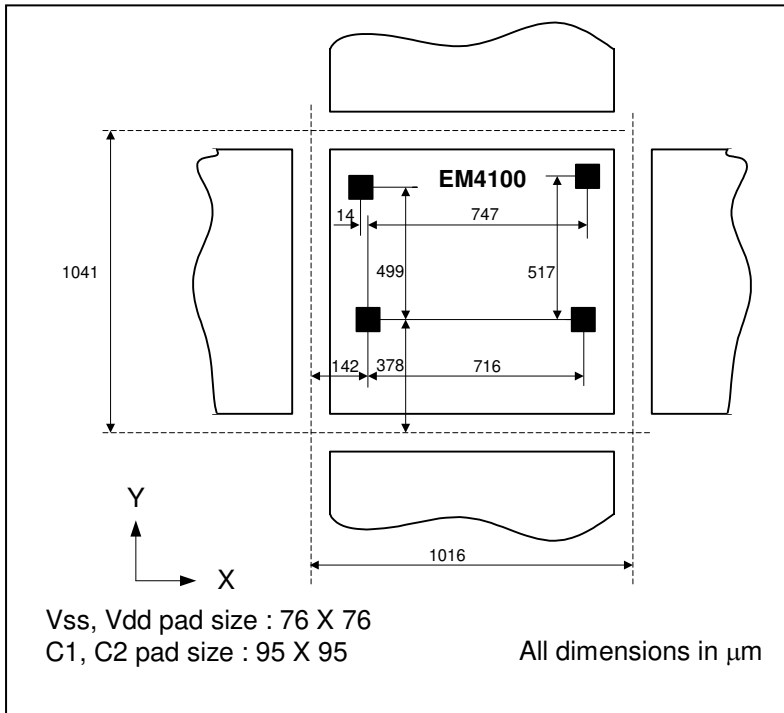

Fig. 13

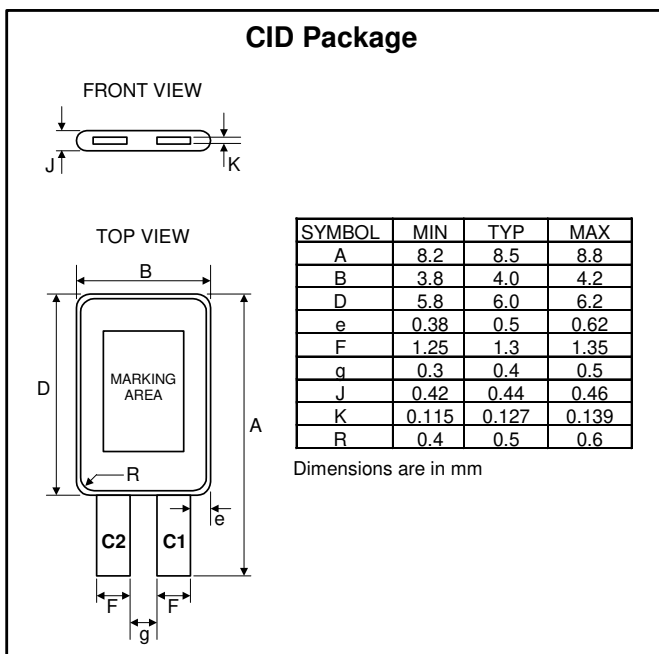

Fig. 14

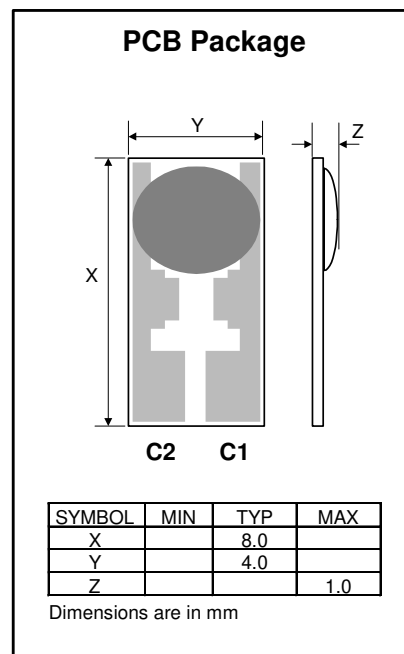

Fig. 15



Ordering Information

Packaged Devices

This chart shows general offering; for detailed Part Number to order, please see the table "Standard Versions" below.

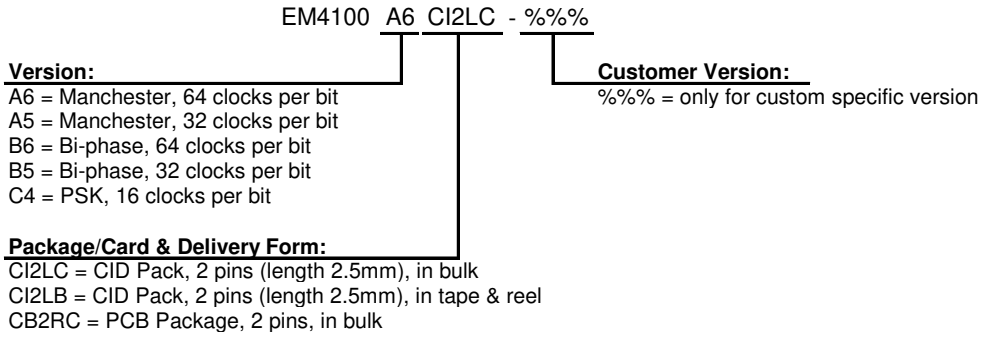

Die Form

This chart shows general offering; for detailed Part Number to order, please see the table "Standard Versions" below.

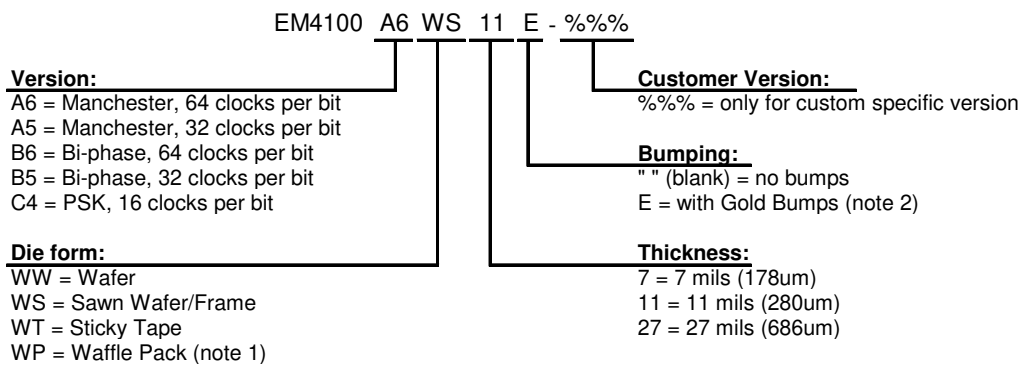

Remarks:

- For ordering please use table of "Standard Version" table below.
- **Note 1:** This is a non-standard package. Please contact EM Microelectronic-Marin S.A for availability.
- **Note 2 :** Direct connection using this version is subject to license.



Standard Versions:

The versions below are considered standards and should be readily available. For other versions or other delivery form, please contact Sales Office. Please make sure to give complete part number when ordering, without spaces.

Part Number	Bit coding	Cycle/ bit	Package/Card/Die Form	Delivery Form / Bumping
EM4100A5CB2RC	Manchester	32	PCB Package, 2 pins	bulk
EM4100A5CI2LC	Manchester	32	CID package, 2 pins (length 2.5mm)	bulk
EM4100A6CB2RC	Manchester	64	PCB Package, 2 pins	bulk
EM4100A6CI2LB	Manchester	64	CID package, 2 pins (length 2.5mm)	tape
EM4100A6CI2LC	Manchester	64	CID package, 2 pins (length 2.5mm)	bulk
EM4100A6WP7	Manchester	64	Die in waffle pack, 7 mils	no bumps
EM4100A6WS7	Manchester	64	Sawn wafer, 7 mils	no bumps
EM4100A6WT7	Manchester	64	Die on sticky tape, 7 mils	no bumps
EM4100A6WW7	Manchester	64	Unsawn wafer, 7 mils	no bumps
EM4100B5CB2RC	Bi-phase	32	PCB Package, 2 pins	bulk
EM4100B5CI2LC	Bi-phase	32	CID package, 2 pins (length 2.5mm)	bulk
EM4100B6CB2RC	Bi-phase	64	PCB Package, 2 pins	bulk
EM4100B6CI2LC	Bi-phase	64	CID package, 2 pins (length 2.5mm)	bulk
EM4100C4WS11	PSK	16	Sawn wafer, 11 mils thickness	no bumps
EM4100XXYYY-%%%	custom		custom	custom