

XU224-1024-FB374 Datasheet

Table of Contents

1	xCORE Multicore Microcontrollers	2
2	XU224-1024-FB374 Features	5
3	Pin Configuration	6
4	Signal Description	7
5	Example Application Diagram	13
6	Product Overview	14
7	PLL	17
8	Boot Procedure	18
9	Memory	21
10	USB PHY	23
11	JTAG	24
12	Board Integration	25
13	DC and Switching Characteristics	29
14	Package Information	33
15	Ordering Information	34
	Appendices	35
A	Configuration of the XU224-1024-FB374	35
B	Processor Status Configuration	38
C	Tile Configuration	49
D	Node Configuration	57
E	USB Node Configuration	65
F	USB PHY Configuration	67
G	JTAG, xSCOPE and Debugging	74
H	Schematics Design Check List	76
I	PCB Layout Design Check List	78
J	Associated Design Documentation	79
K	Related Documentation	79
L	Revision History	80

TO OUR VALUED CUSTOMERS

It is our intention to provide you with accurate and comprehensive documentation for the hardware and software components used in this product. To subscribe to receive updates, visit <http://www.xmos.com/>.

XMOS Ltd. is the owner or licensee of the information in this document and is providing it to you "AS IS" with no warranty of any kind, express or implied and shall have no liability in relation to its use. XMOS Ltd. makes no representation that the information, or any particular implementation thereof, is or will be free from any claims of infringement and again, shall have no liability in relation to any such claims.

XMOS and the XMOS logo are registered trademarks of XMOS Ltd in the United Kingdom and other countries, and may not be used without written permission. Company and product names mentioned in this document are the trademarks or registered trademarks of their respective owners.

1 xCORE Multicore Microcontrollers

The xCORE-200 Series is a comprehensive range of 32-bit multicore microcontrollers that brings the low latency and timing determinism of the xCORE architecture to mainstream embedded applications. Unlike conventional microcontrollers, xCORE multicore microcontrollers execute multiple real-time tasks simultaneously and communicate between tasks using a high speed network. Because xCORE multicore microcontrollers are completely deterministic, you can write software to implement functions that traditionally require dedicated hardware.

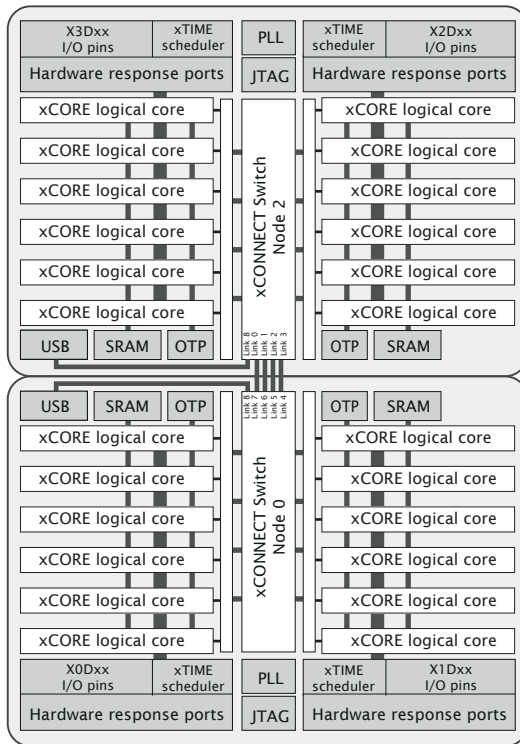

Figure 1:
XU224-1024-
FB374 block
diagram

Key features of the XU224-1024-FB374 include:

- ▶ **Tiles:** Devices consist of one or more xCORE tiles. Each tile contains between five and eight 32-bit xCOREs with highly integrated I/O and on-chip memory.
- ▶ **Logical cores** Each logical core can execute tasks such as computational code, DSP code, control software (including logic decisions and executing a state machine) or software that handles I/O. Section 6.1
- ▶ **xTIME scheduler** The xTIME scheduler performs functions similar to an RTOS, in hardware. It services and synchronizes events in a core, so there is no requirement for interrupt handler routines. The xTIME scheduler triggers cores

on events generated by hardware resources such as the I/O pins, communication channels and timers. Once triggered, a core runs independently and concurrently to other cores, until it pauses to wait for more events. Section [6.2](#)

- ▶ **Channels and channel ends** Tasks running on logical cores communicate using channels formed between two channel ends. Data can be passed synchronously or asynchronously between the channel ends assigned to the communicating tasks. Section [6.5](#)
- ▶ **xCONNECT Switch and Links** Between tiles, channel communications are implemented over a high performance network of xCONNECT Links and routed through a hardware xCONNECT Switch. Section [6.6](#)
- ▶ **Ports** The I/O pins are connected to the processing cores by Hardware Response ports. The port logic can drive its pins high and low, or it can sample the value on its pins optionally waiting for a particular condition. Section [6.3](#)
- ▶ **Clock blocks** xCORE devices include a set of programmable clock blocks that can be used to govern the rate at which ports execute. Section [6.4](#)
- ▶ **Memory** Each xCORE Tile integrates a bank of SRAM for instructions and data, and a block of one-time programmable (OTP) memory that can be configured for system wide security features. Section [9](#)
- ▶ **PLL** The PLL is used to create a high-speed processor clock given a low speed external oscillator. Section [7](#)
- ▶ **USB** The USB PHY provides High-Speed and Full-Speed, device, host, and on-the-go functionality. Data is communicated through ports on the digital node. A library is provided to implement USB device functionality. Section [10](#)
- ▶ **JTAG** The JTAG module can be used for loading programs, boundary scan testing, in-circuit source-level debugging and programming the OTP memory. Section [11](#)

1.1 Software

Devices are programmed using C, C++ or xC (C with multicore extensions). XMOS provides tested and proven software libraries, which allow you to quickly add interface and processor functionality such as USB, Ethernet, PWM, graphics driver, and audio EQ to your applications.

1.2 xTIMEcomposer Studio

The xTIMEcomposer Studio development environment provides all the tools you need to write and debug your programs, profile your application, and write images into flash memory or OTP memory on the device. Because xCORE devices operate deterministically, they can be simulated like hardware within xTIMEcomposer: uniquely in the embedded world, xTIMEcomposer Studio therefore includes a static timing analyzer, cycle-accurate simulator, and high-speed in-circuit instrumentation.

xTIMEcomposer can be driven from either a graphical development environment, or the command line. The tools are supported on Windows, Linux and MacOS X and available at no cost from [xmos.com/downloads](https://www.xmos.com/downloads). Information on using the tools is provided in the xTIMEcomposer User Guide, [X3766](#).

2 XU224-1024-FB374 Features

▶ **Multicore Microcontroller with Advanced Multi-Core RISC Architecture**

- 24 real-time logical cores on 4 xCORE tiles
- Cores share up to 2000 MIPS
 - Up to 4000 MIPS in dual issue mode
- Each logical core has:
 - Guaranteed throughput of between $\frac{1}{5}$ and $\frac{1}{6}$ of tile MIPS
 - 16x32bit dedicated registers
- 167 high-density 16/32-bit instructions
 - All have single clock-cycle execution (except for divide)
 - 32x32→64-bit MAC instructions for DSP, arithmetic and user-definable cryptographic functions

▶ **Dual USB PHY, fully compliant with USB 2.0 specification**

▶ **Programmable I/O**

- 176 general-purpose I/O pins, configurable as input or output
 - Up to 56 x 1bit port, 22 x 4bit port, 13 x 8bit port, 6 x 16bit port, 4 x 32bit port
 - 8 xCONNECT links
- Port sampling rates of up to 60 MHz with respect to an external clock
- 128 channel ends (32 per tile) for communication with other cores, on or off-chip

▶ **Memory**

- 1024KB internal single-cycle SRAM (max 256KB per tile) for code and data storage
- 32KB internal OTP (max 8KB per tile) for application boot code

▶ **Hardware resources**

- 24 clock blocks (6 per tile)
- 40 timers (10 per tile)
- 16 locks (4 per tile)

▶ **JTAG Module for On-Chip Debug**

▶ **Security Features**

- Programming lock disables debug and prevents read-back of memory contents
- AES bootloader ensures secrecy of IP held on external flash memory

▶ **Ambient Temperature Range**

- Commercial qualification: 0°C to 70°C
- Industrial qualification: -40°C to 85°C

▶ **Speed Grade**

- 40: 2000 MIPS

▶ **Power Consumption**

- 1140 mA (typical)

▶ **374-pin FBGA package 0.8 mm pitch**

3 Pin Configuration

	1	2	3	4	5	6	7	8	9	10	11	12	13	14	15	16	17	18	19	20	21		
A	GND	VDDIO	X1D11	X1D02	X1D26	VDDIO_T	X1D41	X0D31	X0D29	TDI	VDDIO	CLK	TDO	X3D32	X3D30	VDDIO_T_2	X2D31	X2D29	X2D32	VDDIO	GND		
B	X0D37	X0D36	X1D10	X1D33	X1D27	X1D42	X1D40	X0D30	X0D28	X2D36	GND	RST_N	TCK	X3D33	X3D31	X3D27	X2D30	X2D28	X2D27	X2D26	X2D35		
C	X0D39	X0D38	VDD	X1D30	X1D28	X1D43	GND	X0D33	X0D32	MODE1	OTP_VCC	TRST_N	X3D10	X3D29	GND	X3D43	X3D41	X2D33	VDD	X2D25	X2D34		
D	X0D41	X0D40	X1D34	X1D01	X1D29	GND	VDDIO	NC	DEBUQ_N	MODE0		TMS	X3D11	X3D28	X3D26	X3D42	X3D40	X2D70	X3D00	X3D01	X2D24		
E	X0D43	X0D42	X1D35	VDD	VDD	GND	VDDIO	VDD	VDD				VDD	VDD	VDDIO	GND	VDD	VDD	VDD	X2D69	X3D08	X3D09	
F	X1D36	VDDIO	GND	VDD	VDD	VDD	VDD	VDD	VDD	PLL_AGND	PLL_AVDD	VDD	VDD	VDD	VDD	VDD	VDD	VDD	VDD	GND	VDDIO	X2D68	
G	X1D49	X1D50	X1D51	NC	NC	NC	NC	NC	NC				NC	NC	NC	NC	NC	NC	NC	X2D67	X2D66	X2D65	
H	X1D53	X1D52	VDD																	VDD	X2D63	X2D64	
J	X1D54	X1D55	VDD		GND	GND	GND	GND	GND				GND	GND	GND	GND	GND	GND		VDD	X2D62	X2D61	
K	X1D58	X1D57	X1D56		GND	GND	GND	GND	GND				GND	GND	GND	GND	GND	GND		X2D56	X2D57	X2D58	
L	VDDIO	GND	X1D61		GND	GND	GND	GND	GND				GND	GND	GND	GND	GND	GND		X2D55	GND	VDDIO	
M	X1D64	X1D63	X1D62		GND	GND	GND	GND	GND				GND	GND	GND	GND	GND	GND		X2D54	X2D53	X2D52	
N	X1D65	X1D66	VDD		GND	GND	GND	GND	GND				GND	GND	GND	GND	GND	GND		VDD	X2D50	X2D51	
P	X1D68	X1D67	VDD																	VDD	X3D06	X3D07	
R	X1D69	X1D70	X1D71	NC	NC	NC	NC	NC	NC				NC	NC	NC	NC	NC	NC	NC	NC	X2D49	X3D04	X3D05
T	X1D38	VDDIO	GND	VDD	VDD	VDD	USB_VDD	VDD	VDD	VDD	GND	VDD	VDD	VDD	VDD	USB_2_VDD-	VDD	VDD	VDD	GND	VDDIO	X3D03	
U	X1D17	X1D16	X1D39	VDD	VDD	GND	VDDIO	NC	VDD		VDDIO		VDD	VDD	VDDIO	GND	VDD	VDD	NC	X2D19	X3D02		
V	X1D19	X1D18	X0D01	X0D02	X0D08	X0D11	USB_ID	X1D14	X1D25	X0D21	NC	X3D23	X3D05	X3D07	USB_2_ID-	NC	X3D15	X3D21	X2D12	X2D17	X2D18		
W	X0D10	X1D22	USB_VDD33	X0D03	X0D09	USB_RTUNE	GND	X1D15	X0D14	X0D12	X0D23	X2D00	X2D04	X2D06	GND	USB_2_RTUNE	X3D14	X3D20	USB_2_VDD33	X2D23	X2D16		
Y	X1D23	X0D00	X0D04	X0D06	X1D12	USB_VBUS	X1D24	X1D20	X0D15	X0D13	GND	X2D11	X2D02	X2D08	X3D13	USB_2_VBUS	X2D14	X2D20	X3D24	X2D13	X2D22		
AA	GND	VDDIO	X0D05	X0D07	X1D13	USB_DM	USB_DP	X1D21	X0D20	X0D22	VDDIO	X3D12	X2D03	X2D09	USB_2_DM	USB_2_DP-	X2D15	X2D21	X3D25	VDDIO	GND		

4 Signal Description

This section lists the signals and I/O pins available on the XU224-1024-FB374. The device provides a combination of 1bit, 4bit, 8bit and 16bit ports, as well as wider ports that are fully or partially (gray) bonded out. All pins of a port provide either output or input, but signals in different directions cannot be mapped onto the same port.

Pins may have one or more of the following properties:

- ▶ PD/PU: The IO pin has a weak pull-down or pull-up resistor. On GPIO pins this resistor can be enabled. This resistor is designed to ensure defined logic input state for unconnected pins. It should not be used to pull external circuitry. Note that the resistors are highly non-linear and only a maximum pull current is specified in Section 13.2.
- ▶ ST: The IO pin has a Schmitt Trigger on its input.
- ▶ IOT: The IO pin is powered from VDDIOT (X1) or VDDIOT_2 (X3), not VDDIO
- ▶ IO: the pin is powered from VDDIO

Power pins (12)			
Signal	Function	Type	Properties
GND	Digital ground	GND	
OTP_VCC	OTP power supply	PWR	
PLL_AGND	Analog ground for PLL	PWR	
PLL_AVDD	Analog PLL power	PWR	
USB_2_VDD	Digital tile power	PWR	
USB_2_VDD33	USB Analog power	PWR	
USB_VDD	Digital tile power	PWR	
USB_VDD33	USB Analog power	PWR	
VDD	Digital tile power	PWR	
VDDIO	Digital I/O power	PWR	
VDDIOT	Digital I/O power (top)	PWR	
VDDIOT_2	Digital I/O power (top, X3)	PWR	

JTAG pins (6)			
Signal	Function	Type	Properties
RST_N	Global reset input	Input	IO, PU, ST
TCK	Test clock	Input	IO, PD, ST
TDI	Test data input	Input	IO, PU
TDO	Test data output	Output	IO, PD
TMS	Test mode select	Input	IO, PU
TRST_N	Test reset input	Input	IO, PU, ST

I/O pins (176)						
Signal	Function				Type	Properties
X0D00	1A ⁰				I/O	IO, PD
X0D01	X ₀ L3 _{out} ²	1B ⁰			I/O	IO, PD
X0D02	4A ⁰ 8A ⁰ 16A ⁰ 32A ²⁰				I/O	IO, PD
X0D03	4A ¹ 8A ¹ 16A ¹ 32A ²¹				I/O	IO, PD
X0D04	4B ⁰ 8A ² 16A ² 32A ²²				I/O	IO, PD
X0D05	4B ¹ 8A ³ 16A ³ 32A ²³				I/O	IO, PD
X0D06	4B ² 8A ⁴ 16A ⁴ 32A ²⁴				I/O	IO, PD
X0D07	4B ³ 8A ⁵ 16A ⁵ 32A ²⁵				I/O	IO, PD
X0D08	4A ² 8A ⁶ 16A ⁶ 32A ²⁶				I/O	IO, PD
X0D09	4A ³ 8A ⁷ 16A ⁷ 32A ²⁷				I/O	IO, PD
X0D10	X ₀ L3 _{out} ³	1C ⁰			I/O	IO, PD
X0D11	1D ⁰				I/O	IO, PD
X0D12	1E ⁰				I/O	IO, PD
X0D13	1F ⁰				I/O	IO, PD
X0D14	4C ⁰ 8B ⁰ 16A ⁸ 32A ²⁸				I/O	IO, PD
X0D15	4C ¹ 8B ¹ 16A ⁹ 32A ²⁹				I/O	IO, PD
X0D20	4C ² 8B ⁶ 16A ¹⁴ 32A ³⁰				I/O	IO, PD
X0D21	4C ³ 8B ⁷ 16A ¹⁵ 32A ³¹				I/O	IO, PD
X0D22	1G ⁰				I/O	IO, PD
X0D23	1H ⁰				I/O	IO, PD
X0D28	4F ⁰ 8C ² 16B ²				I/O	IO, PD
X0D29	4F ¹ 8C ³ 16B ³				I/O	IO, PD
X0D30	4F ² 8C ⁴ 16B ⁴				I/O	IO, PD
X0D31	4F ³ 8C ⁵ 16B ⁵				I/O	IO, PD
X0D32	4E ² 8C ⁶ 16B ⁶				I/O	IO, PD
X0D33	4E ³ 8C ⁷ 16B ⁷				I/O	IO, PD
X0D36	1M ⁰ 8D ⁰ 16B ⁸				I/O	IO, PD
X0D37	X ₀ L0 _{in} ⁴	1N ⁰ 8D ¹ 16B ⁹			I/O	IO, PD
X0D38	X ₀ L0 _{in} ³	1O ⁰ 8D ² 16B ¹⁰			I/O	IO, PD
X0D39	X ₀ L0 _{in} ²	1P ⁰ 8D ³ 16B ¹¹			I/O	IO, PD
X0D40	X ₀ L0 _{in} ¹	8D ⁴ 16B ¹²			I/O	IO, PD
X0D41	X ₀ L0 _{in} ⁰	8D ⁵ 16B ¹³			I/O	IO, PD
X0D42	X ₀ L0 _{out} ⁰	8D ⁶ 16B ¹⁴			I/O	IO, PD
X0D43	X ₀ L0 _{out} ¹	8D ⁷ 16B ¹⁵			I/O	IO, PD
X1D10	1C ⁰				I/O	IOT, PD
X1D11	1D ⁰				I/O	IOT, PD
X1D12	1E ⁰				I/O	IO, PD
X1D13	1F ⁰				I/O	IO, PD
X1D14	4C ⁰ 8B ⁰ 16A ⁸ 32A ²⁸				I/O	IO, PD
X1D15	4C ¹ 8B ¹ 16A ⁹ 32A ²⁹				I/O	IO, PD
X1D16	X ₀ L3 _{in} ¹	4D ⁰ 8B ² 16A ¹⁰			I/O	IO, PD

(continued)

Signal	Function	Type	Properties
X1D17	$X_0L3_{in}^0$ 4D ¹ 8B ³ 16A ¹¹	I/O	IO, PD
X1D18	$X_0L3_{out}^0$ 4D ² 8B ⁴ 16A ¹²	I/O	IO, PD
X1D19	$X_0L3_{out}^0$ 4D ³ 8B ⁵ 16A ¹³	I/O	IO, PD
X1D20	4C ² 8B ⁶ 16A ¹⁴ 32A ³⁰	I/O	IO, PD
X1D21	4C ³ 8B ⁷ 16A ¹⁵ 32A ³¹	I/O	IO, PD
X1D22	$X_0L3_{out}^4$ 1C ⁰	I/O	IO, PD
X1D23	1H ⁰	I/O	IO, PD
X1D24	1I ⁰	I/O	IO, PD
X1D25	1J ⁰	I/O	IO, PD
X1D26	4E ⁰ 8C ⁰ 16B ⁰	I/O	IOT, PD
X1D27	4E ¹ 8C ¹ 16B ¹	I/O	IOT, PD
X1D28	4F ⁰ 8C ² 16B ²	I/O	IOT, PD
X1D29	4F ¹ 8C ³ 16B ³	I/O	IOT, PD
X1D30	4F ² 8C ⁴ 16B ⁴	I/O	IOT, PD
X1D31	4F ³ 8C ⁵ 16B ⁵	I/O	IOT, PD
X1D32	4E ² 8C ⁶ 16B ⁶	I/O	IOT, PD
X1D33	4E ³ 8C ⁷ 16B ⁷	I/O	IOT, PD
X1D34	$X_0L0_{out}^2$ 1K ⁰	I/O	IO, PD
X1D35	$X_0L0_{out}^3$ 1L ⁰	I/O	IO, PD
X1D36	$X_0L0_{out}^4$ 1M ⁰ 8D ⁰ 16B ⁸	I/O	IO, PD
X1D37	$X_0L3_{in}^4$ 1N ⁰ 8D ¹ 16B ⁹	I/O	IO, PD
X1D38	$X_0L3_{in}^3$ 1O ⁰ 8D ² 16B ¹⁰	I/O	IO, PD
X1D39	$X_0L3_{in}^2$ 1P ⁰ 8D ³ 16B ¹¹	I/O	IO, PD
X1D40	8D ⁴ 16B ¹²	I/O	IOT, PD
X1D41	8D ⁵ 16B ¹³	I/O	IOT, PD
X1D42	8D ⁶ 16B ¹⁴	I/O	IOT, PD
X1D43	8D ⁷ 16B ¹⁵	I/O	IOT, PD
X1D49	$X_0L1_{in}^4$ 32A ⁰	I/O	IO, PD
X1D50	$X_0L1_{in}^3$ 32A ¹	I/O	IO, PD
X1D51	$X_0L1_{in}^2$ 32A ²	I/O	IO, PD
X1D52	$X_0L1_{in}^1$ 32A ³	I/O	IO, PD
X1D53	$X_0L1_{in}^0$ 32A ⁴	I/O	IO, PD
X1D54	$X_0L1_{out}^0$ 32A ⁵	I/O	IO, PD
X1D55	$X_0L1_{out}^1$ 32A ⁶	I/O	IO, PD
X1D56	$X_0L1_{out}^2$ 32A ⁷	I/O	IO, PD
X1D57	$X_0L1_{out}^3$ 32A ⁸	I/O	IO, PD
X1D58	$X_0L1_{out}^4$ 32A ⁹	I/O	IO, PD
X1D61	$X_0L2_{in}^4$ 32A ¹⁰	I/O	IO, PD
X1D62	$X_0L2_{in}^3$ 32A ¹¹	I/O	IO, PD
X1D63	$X_0L2_{in}^2$ 32A ¹²	I/O	IO, PD
X1D64	$X_0L2_{in}^1$ 32A ¹³	I/O	IO, PD
X1D65	$X_0L2_{in}^0$ 32A ¹⁴	I/O	IO, PD
X1D66	$X_0L2_{out}^0$ 32A ¹⁵	I/O	IO, PD

(continued)

Signal	Function	Type	Properties
X1D67	$X_0L2_{out}^1$ 32A ¹⁶	I/O	IO, PD
X1D68	$X_0L2_{out}^2$ 32A ¹⁷	I/O	IO, PD
X1D69	$X_0L2_{out}^3$ 32A ¹⁸	I/O	IO, PD
X1D70	$X_0L2_{out}^4$ 32A ¹⁹	I/O	IO, PD
X2D00	1A ⁰	I/O	IO, PD
X2D02	4A ⁰ 8A ⁰ 16A ⁰ 32A ²⁰	I/O	IO, PD
X2D03	4A ¹ 8A ¹ 16A ¹ 32A ²¹	I/O	IO, PD
X2D04	4B ⁰ 8A ² 16A ² 32A ²²	I/O	IO, PD
X2D05	4B ¹ 8A ³ 16A ³ 32A ²³	I/O	IO, PD
X2D06	4B ² 8A ⁴ 16A ⁴ 32A ²⁴	I/O	IO, PD
X2D07	4B ³ 8A ⁵ 16A ⁵ 32A ²⁵	I/O	IO, PD
X2D08	4A ² 8A ⁶ 16A ⁶ 32A ²⁶	I/O	IO, PD
X2D09	4A ³ 8A ⁷ 16A ⁷ 32A ²⁷	I/O	IO, PD
X2D11	1D ⁰	I/O	IO, PD
X2D12	1E ⁰	I/O	IO, PD
X2D13	1F ⁰	I/O	IO, PD
X2D14	4C ⁰ 8B ⁰ 16A ⁸ 32A ²⁸	I/O	IO, PD
X2D15	4C ¹ 8B ¹ 16A ⁹ 32A ²⁹	I/O	IO, PD
X2D16	$X_2L4_{in}^4$ 4D ⁰ 8B ² 16A ¹⁰	I/O	IO, PD
X2D17	$X_2L4_{in}^3$ 4D ¹ 8B ³ 16A ¹¹	I/O	IO, PD
X2D18	$X_2L4_{in}^2$ 4D ² 8B ⁴ 16A ¹²	I/O	IO, PD
X2D19	$X_2L4_{in}^1$ 4D ³ 8B ⁵ 16A ¹³	I/O	IO, PD
X2D20	4C ² 8B ⁶ 16A ¹⁴ 32A ³⁰	I/O	IO, PD
X2D21	4C ³ 8B ⁷ 16A ¹⁵ 32A ³¹	I/O	IO, PD
X2D22	1G ⁰	I/O	IO, PD
X2D23	1H ⁰	I/O	IO, PD
X2D24	$X_2L7_{in}^0$ 1I ⁰	I/O	IO, PD
X2D25	$X_2L7_{out}^0$ 1J ⁰	I/O	IO, PD
X2D26	$X_2L7_{out}^3$ 4E ⁰ 8C ⁰ 16B ⁰	I/O	IO, PD
X2D27	$X_2L7_{out}^4$ 4E ¹ 8C ¹ 16B ¹	I/O	IO, PD
X2D28	4F ⁰ 8C ² 16B ²	I/O	IO, PD
X2D29	4F ¹ 8C ³ 16B ³	I/O	IO, PD
X2D30	4F ² 8C ⁴ 16B ⁴	I/O	IO, PD
X2D31	4F ³ 8C ⁵ 16B ⁵	I/O	IO, PD
X2D32	4E ² 8C ⁶ 16B ⁶	I/O	IO, PD
X2D33	4E ³ 8C ⁷ 16B ⁷	I/O	IO, PD
X2D34	$X_2L7_{out}^1$ 1K ⁰	I/O	IO, PD
X2D35	$X_2L7_{out}^2$ 1L ⁰	I/O	IO, PD
X2D36	1M ⁰ 8D ⁰ 16B ⁸	I/O	IO, PD
X2D49	$X_2L5_{in}^4$ 32A ⁰	I/O	IO, PD
X2D50	$X_2L5_{in}^3$ 32A ¹	I/O	IO, PD
X2D51	$X_2L5_{in}^2$ 32A ²	I/O	IO, PD
X2D52	$X_2L5_{in}^1$ 32A ³	I/O	IO, PD

(continued)

Signal	Function	Type	Properties
X2D53	$X_2L5_{in}^0$ 32A ⁴	I/O	IO, PD
X2D54	$X_2L5_{out}^0$ 32A ⁵	I/O	IO, PD
X2D55	$X_2L5_{out}^1$ 32A ⁶	I/O	IO, PD
X2D56	$X_2L5_{out}^2$ 32A ⁷	I/O	IO, PD
X2D57	$X_2L5_{out}^3$ 32A ⁸	I/O	IO, PD
X2D58	$X_2L5_{out}^4$ 32A ⁹	I/O	IO, PD
X2D61	$X_2L6_{in}^4$ 32A ¹⁰	I/O	IO, PD
X2D62	$X_2L6_{in}^3$ 32A ¹¹	I/O	IO, PD
X2D63	$X_2L6_{in}^2$ 32A ¹²	I/O	IO, PD
X2D64	$X_2L6_{in}^1$ 32A ¹³	I/O	IO, PD
X2D65	$X_2L6_{in}^0$ 32A ¹⁴	I/O	IO, PD
X2D66	$X_2L6_{out}^0$ 32A ¹⁵	I/O	IO, PD
X2D67	$X_2L6_{out}^1$ 32A ¹⁶	I/O	IO, PD
X2D68	$X_2L6_{out}^2$ 32A ¹⁷	I/O	IO, PD
X2D69	$X_2L6_{out}^3$ 32A ¹⁸	I/O	IO, PD
X2D70	$X_2L6_{out}^4$ 32A ¹⁹	I/O	IO, PD
X3D00	$X_2L7_{in}^2$ 1A ⁰	I/O	IO, PD
X3D01	$X_2L7_{in}^1$ 1B ⁰	I/O	IO, PD
X3D02	$X_2L4_{in}^0$ 4A ⁰ 8A ⁰ 16A ⁰ 32A ²⁰	I/O	IO, PD
X3D03	$X_2L4_{out}^0$ 4A ¹ 8A ¹ 16A ¹ 32A ²¹	I/O	IO, PD
X3D04	$X_2L4_{out}^1$ 4B ⁰ 8A ² 16A ² 32A ²²	I/O	IO, PD
X3D05	$X_2L4_{out}^2$ 4B ¹ 8A ³ 16A ³ 32A ²³	I/O	IO, PD
X3D06	$X_2L4_{out}^3$ 4B ² 8A ⁴ 16A ⁴ 32A ²⁴	I/O	IO, PD
X3D07	$X_2L4_{out}^4$ 4B ³ 8A ⁵ 16A ⁵ 32A ²⁵	I/O	IO, PD
X3D08	$X_2L7_{in}^4$ 4A ² 8A ⁶ 16A ⁶ 32A ²⁶	I/O	IO, PD
X3D09	$X_2L7_{in}^3$ 4A ³ 8A ⁷ 16A ⁷ 32A ²⁷	I/O	IO, PD
X3D10	1C ⁰	I/O	IOT, PD
X3D11	1D ⁰	I/O	IOT, PD
X3D12	1E ⁰	I/O	IO, PD
X3D13	1F ⁰	I/O	IO, PD
X3D14	4C ⁰ 8B ⁰ 16A ⁸ 32A ²⁸	I/O	IO, PD
X3D15	4C ¹ 8B ¹ 16A ⁹ 32A ²⁹	I/O	IO, PD
X3D20	4C ² 8B ⁶ 16A ¹⁴ 32A ³⁰	I/O	IO, PD
X3D21	4C ³ 8B ⁷ 16A ¹⁵ 32A ³¹	I/O	IO, PD
X3D23	1H ⁰	I/O	IO, PD
X3D24	1I ⁰	I/O	IO, PD
X3D25	1J ⁰	I/O	IO, PD
X3D26	4E ⁰ 8C ⁰ 16B ⁰	I/O	IOT, PD
X3D27	4E ¹ 8C ¹ 16B ¹	I/O	IOT, PD
X3D28	4F ⁰ 8C ² 16B ²	I/O	IOT, PD
X3D29	4F ¹ 8C ³ 16B ³	I/O	IOT, PD
X3D30	4F ² 8C ⁴ 16B ⁴	I/O	IOT, PD
X3D31	4F ³ 8C ⁵ 16B ⁵	I/O	IOT, PD

(continued)

Signal	Function	Type	Properties
X3D32	4E ² 8C ⁶ 16B ⁶	I/O	IOT, PD
X3D33	4E ³ 8C ⁷ 16B ⁷	I/O	IOT, PD
X3D40	8D ⁴ 16B ¹²	I/O	IOT, PD
X3D41	8D ⁵ 16B ¹³	I/O	IOT, PD
X3D42	8D ⁶ 16B ¹⁴	I/O	IOT, PD
X3D43	8D ⁷ 16B ¹⁵	I/O	IOT, PD

System pins (4)			
Signal	Function	Type	Properties
CLK	PLL reference clock	Input	IO, PD, ST
DEBUG_N	Multi-chip debug	I/O	IO, PU
MODE0	Boot mode select	Input	PU
MODE1	Boot mode select	Input	PU

usb pins (10)			
Signal	Function	Type	Properties
USB_2_DM	USB Serial Data Inverted, node 2	I/O	
USB_2_DP	USB Serial Data, node 2	I/O	
USB_2_ID	USB Device ID (OTG) - Reserved, node 2	I/O	
USB_2_RTUNE	USB resistor, node 2	I/O	
USB_2_VBUS	USB Power Detect Pin, node 2	I/O	
USB_DM	USB Serial Data Inverted	I/O	
USB_DP	USB Serial Data	I/O	
USB_ID	USB Device ID (OTG) - Reserved	I/O	
USB_RTUNE	USB resistor	I/O	
USB_VBUS	USB Power Detect Pin	I/O	

5 Example Application Diagram

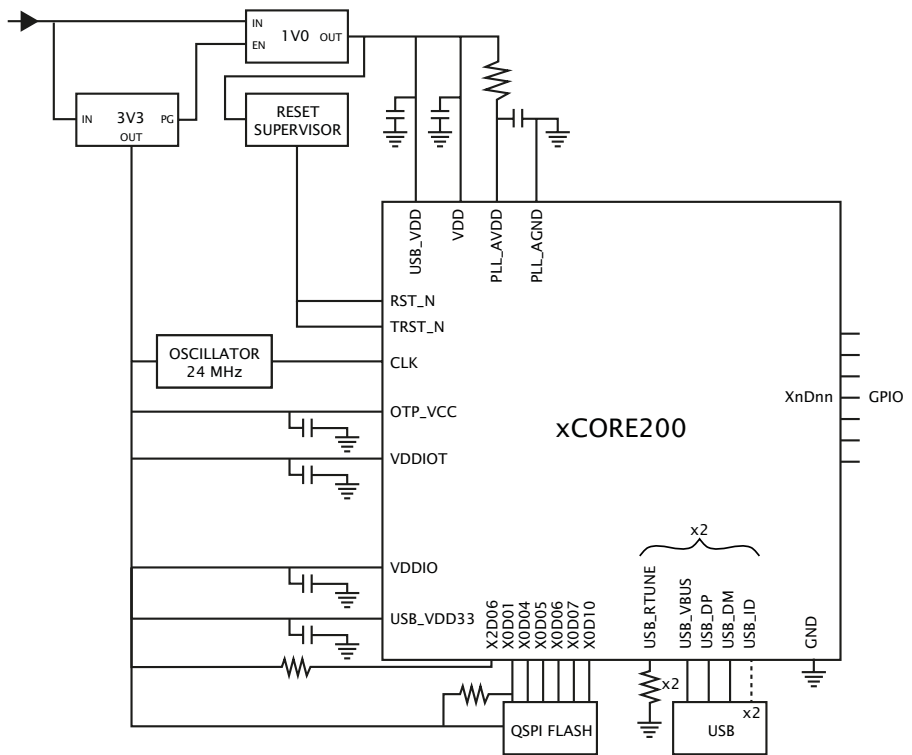

Figure 2:
Simplified
Reference
Schematic

- ▶ see Section 10 for details on the USB PHY
- ▶ see Section 12 for details on the power supplies and PCB design

6 Product Overview

The XU224-1024-FB374 is a powerful device that consists of four xCORE Tiles, each comprising a flexible logical processing cores with tightly integrated I/O and on-chip memory.

6.1 Logical cores

Each tile has 6 active logical cores, which issue instructions down a shared five-stage pipeline. Instructions from the active cores are issued round-robin. If up to five logical cores are active, each core is allocated a fifth of the processing cycles. If more than five logical cores are active, each core is allocated at least $1/n$ cycles (for n cores). Figure 3 shows the guaranteed core performance depending on the number of cores used.

Figure 3:
Logical core
performance

Speed grade	MIPS	Frequency	Minimum MIPS per core (for n cores)							
			1	2	3	4	5	6		
20	2000 MIPS	500 MHz	100	100	100	100	100	83		

There is no way that the performance of a logical core can be reduced below these predicted levels (unless *priority threads* are used: in this case the guaranteed minimum performance is computed based on the number of priority threads as defined in the architecture manual). Because cores may be delayed on I/O, however, their unused processing cycles can be taken by other cores. This means that for more than five logical cores, the performance of each core is often higher than the predicted minimum but cannot be guaranteed.

The logical cores are triggered by events instead of interrupts and run to completion. A logical core can be paused to wait for an event.

6.2 xTIME scheduler

The xTIME scheduler handles the events generated by xCORE Tile resources, such as channel ends, timers and I/O pins. It ensures that all events are serviced and synchronized, without the need for an RTOS. Events that occur at the I/O pins are handled by the Hardware-Response ports and fed directly to the appropriate xCORE Tile. An xCORE Tile can also choose to wait for a specified time to elapse, or for data to become available on a channel.

Tasks do not need to be prioritised as each of them runs on their own logical xCORE. It is possible to share a set of low priority tasks on a single core using cooperative multitasking.

6.3 Hardware Response Ports

Hardware Response ports connect an xCORE tile to one or more physical pins and as such define the interface between hardware attached to the XU224-1024-FB374, and the software running on it. A combination of 1bit, 4bit, 8bit, 16bit and 32bit

ports are available. All pins of a port provide either output or input. Signals in different directions cannot be mapped onto the same port.

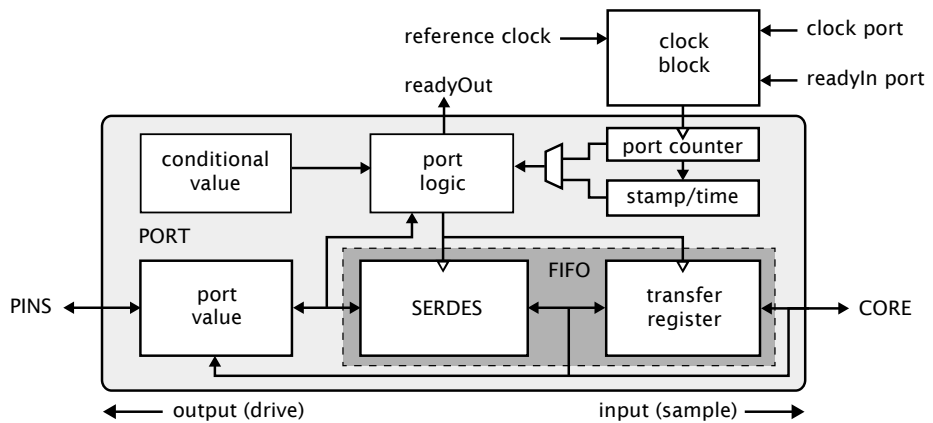

Figure 4:
Port block
diagram

The port logic can drive its pins high or low, or it can sample the value on its pins, optionally waiting for a particular condition. Ports are accessed using dedicated instructions that are executed in a single processor cycle. xCORE-200 IO pins can be used as *open collector* outputs, where signals are driven low if a zero is output, but left high impedance if a one is output. This option is set on a per-port basis.

Data is transferred between the pins and core using a FIFO that comprises a SERDES and transfer register, providing options for serialization and buffered data.

Each port has a 16-bit counter that can be used to control the time at which data is transferred between the port value and transfer register. The counter values can be obtained at any time to find out when data was obtained, or used to delay I/O until some time in the future. The port counter value is automatically saved as a timestamp, that can be used to provide precise control of response times.

The ports and xCONNECT links are multiplexed onto the physical pins. If an xConnect Link is enabled, the pins of the underlying ports are disabled. If a port is enabled, it overrules ports with higher widths that share the same pins. The pins on the wider port that are not shared remain available for use when the narrower port is enabled. Ports always operate at their specified width, even if they share pins with another port.

6.4 Clock blocks

xCORE devices include a set of programmable clocks called clock blocks that can be used to govern the rate at which ports execute. Each xCORE tile has six clock blocks: the first clock block provides the tile reference clock and runs at a default frequency of 100MHz; the remaining clock blocks can be set to run at different frequencies.

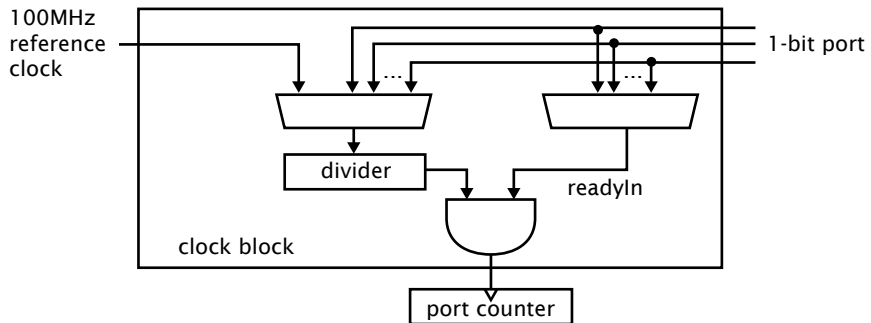

Figure 5:
Clock block
diagram

A clock block can use a 1-bit port as its clock source allowing external application clocks to be used to drive the input and output interfaces. xCORE-200 clock blocks optionally divide the clock input from a 1-bit port.

In many cases I/O signals are accompanied by strobing signals. The xCORE ports can input and interpret strobe (known as readyIn and readyOut) signals generated by external sources, and ports can generate strobe signals to accompany output data.

On reset, each port is connected to clock block 0, which runs from the xCORE Tile reference clock.

6.5 Channels and Channel Ends

Logical cores communicate using point-to-point connections, formed between two channel ends. A channel-end is a resource on an xCORE tile, that is allocated by the program. Each channel-end has a unique system-wide identifier that comprises a unique number and their tile identifier. Data is transmitted to a channel-end by an output-instruction; and the other side executes an input-instruction. Data can be passed synchronously or asynchronously between the channel ends.

6.6 xCONNECT Switch and Links

XMOS devices provide a scalable architecture, where multiple xCORE devices can be connected together to form one system. Each xCORE device has an xCONNECT interconnect that provides a communication infrastructure for all tasks that run on the various xCORE tiles on the system.

The interconnect relies on a collection of switches and XMOS links. Each xCORE device has an on-chip switch that can set up circuits or route data. The switches are connected by xConnect Links. An XMOS link provides a physical connection between two switches. The switch has a routing algorithm that supports many different topologies, including lines, meshes, trees, and hypercubes.

The links operate in either 2 wires per direction or 5 wires per direction mode, depending on the amount of bandwidth required. Circuit switched, streaming

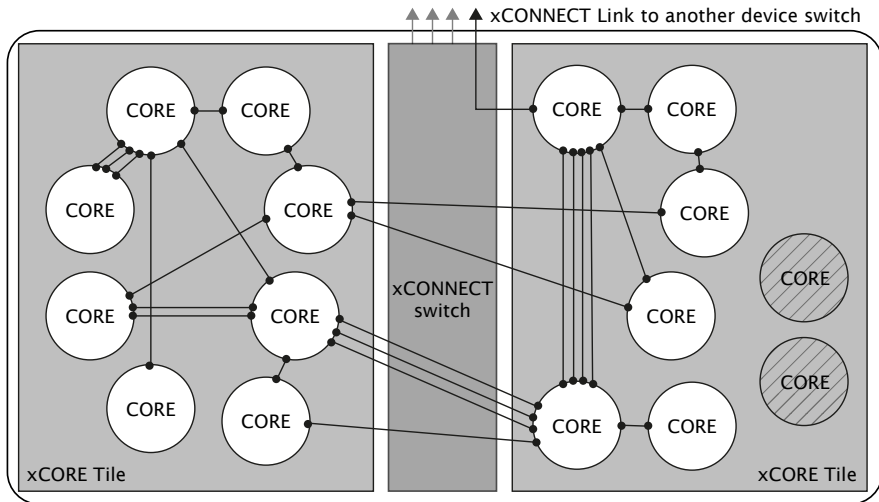

Figure 6:
Switch, links
and channel
ends

and packet switched data can both be supported efficiently. Streams provide the fastest possible data rates between xCORE Tiles (up to 250 MBit/s), but each stream requires a single link to be reserved between switches on two tiles. All packet communications can be multiplexed onto a single link.

Information on the supported routing topologies that can be used to connect multiple devices together can be found in the XS1-U Link Performance and Design Guide, [X2999](#).

7 PLL

The PLL creates a high-speed clock that is used for the switch, tile, and reference clock. The PLL multiplication value is selected through the two MODE pins, and can be changed by software to speed up the tile or use less power. The MODE pins are set as shown in Figure 7:

Oscillator Frequency	MODE		Tile Frequency	PLL Ratio	PLL settings		
	1	0			OD	F	R
3.25-10 MHz	0	0	130-400 MHz	40	1	159	0
9-25 MHz	1	1	144-400 MHz	16	1	63	0
25-50 MHz	1	0	167-400 MHz	8	1	31	0
50-100 MHz	0	1	196-400 MHz	4	1	15	0

Figure 7:
PLL multiplier
values and
MODE pins

Figure 7 also lists the values of OD , F and R , which are the registers that define the ratio of the tile frequency to the oscillator frequency:

$$F_{core} = F_{osc} \times \frac{F+1}{2} \times \frac{1}{R+1} \times \frac{1}{OD+1}$$

OD , F and R must be chosen so that $0 \leq R \leq 63$, $0 \leq F \leq 4095$, $0 \leq OD \leq 7$, and $260\text{MHz} \leq F_{osc} \times \frac{F+1}{2} \times \frac{1}{R+1} \leq 1.3\text{GHz}$. The OD , F , and R values can be modified by writing to the digital node PLL configuration register.

The MODE pins must be held at a static value during and after deassertion of the system reset. If the USB PHY is used, then either a 24 MHz or 12 MHz oscillator must be used.

If a different tile frequency is required (eg, 500 MHz), then the PLL must be reprogrammed after boot to provide the required tile frequency. The XMOS tools perform this operation by default. Further details on configuring the clock can be found in the xCORE-200 Clock Frequency Control document.

8 Boot Procedure

The device is kept in reset by driving RST_N low. When in reset, all GPIO pins have a pull-down enabled. When the device is taken out of reset by releasing RST_N the processor starts its internal reset process. After 15-150 μs (depending on the input clock) the processor boots.

Pin X2D06 must be pulled high with an external pull-up whilst the chip comes out of reset, to ensure that tile 2 will boot from link. X2D04, X2D05, and X2D07 should be kept low whilst the chip comes out of reset.

The xCORE Tile boot procedure is illustrated in Figure 8. If bit 5 of the security register (see §9.1) is set, the device boots from OTP. To get a high value, a 3K3 pull-up resistor should be strapped onto the pin. To assure a low value, a pull-down resistor is required if other external devices are connected to this port.

The boot image has the following format:

- ▶ A 32-bit program size s in words.
- ▶ Program consisting of $s \times 4$ bytes.
- ▶ A 32-bit CRC, or the value 0x0D15AB1E to indicate that no CRC check should be performed.

The program size and CRC are stored least significant byte first. The program is loaded into the lowest memory address of RAM, and the program is started from that address. The CRC is calculated over the byte stream represented by the program size and the program itself. The polynomial used is 0xEDB88320 (IEEE 802.3); the CRC register is initialized with 0xFFFFFFFF and the residue is inverted to produce the CRC.

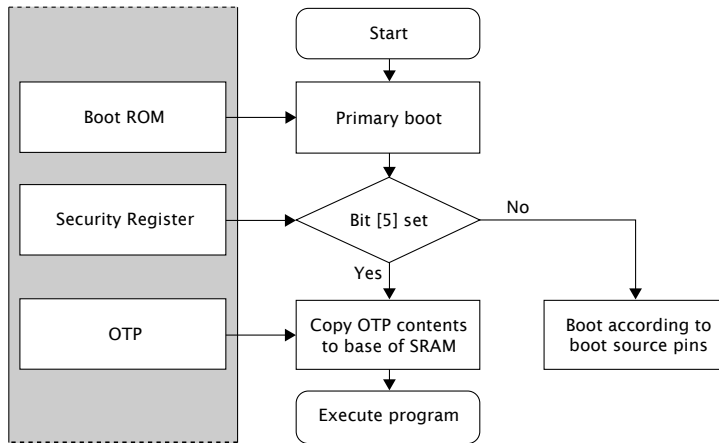

Figure 8:
Boot procedure

X0D06	X0D05	X0D04	Tile 0 boot	Tile 1 boot	Enabled links
0	0	0	QSPI master	Channel end 0	None
0	0	1	SPI master	Channel end 0	None
0	1	0	SPI slave	Channel end 0	None
0	1	1	SPI slave	SPI slave	None
1	0	0	Channel end 0	Channel end 0	XL0 (2w)
1	0	1	Channel end 0	Channel end 0	XL4-XL7 (5w)
1	1	0	Channel end 0	Channel end 0	XL1, XL2, XL5, and XL6 (5w)
1	1	1	Channel end 0	Channel end 0	XL0-XL3 (5w)

Figure 9:
Boot source pins

8.1 Boot from QSPI master

If set to boot from QSPI master, the processor enables the six pins specified in Figure 10, and drives the SPI clock at 50 MHz (assuming a 400 MHz core clock). A READ command is issued with a 24-bit address 0x000000. The clock polarity and phase are 0 / 0.

Pin	Signal	Description
X0D01	SS	Slave Select
X0D04..X0D07	SPIO	Data
X0D10	SCLK	Clock

Figure 10:
QSPI pins

The xCORE Tile expects each byte to be transferred with the *least-significant nibble first*. Programmers who write bytes into an QSPI interface using the most significant nibble first may have to reverse the nibbles in each byte of the image stored in the QSPI device.

The pins used for QSPI boot are hardcoded in the boot ROM and cannot be changed. If required, an QSPI boot program can be burned into OTP that uses different pins.

8.2 Boot from SPI master

If set to boot from SPI master, the processor enables the four pins specified in Figure 11, and drives the SPI clock at 2.5 MHz (assuming a 400 MHz core clock). A READ command is issued with a 24-bit address 0x000000. The clock polarity and phase are 0 / 0.

Figure 11:
SPI master
pins

Pin	Signal	Description
X0D00	MISO	Master In Slave Out (Data)
X0D01	SS	Slave Select
X0D10	SCLK	Clock
X0D11	MOSI	Master Out Slave In (Data)

The xCORE Tile expects each byte to be transferred with the *least-significant bit first*. Programmers who write bytes into an SPI interface using the most significant bit first may have to reverse the bits in each byte of the image stored in the SPI device.

If a large boot image is to be read in, it is faster to first load a small boot-loader that reads the large image using a faster SPI clock, for example 50 MHz or as fast as the flash device supports.

The pins used for SPI boot are hardcoded in the boot ROM and cannot be changed. If required, an SPI boot program can be burned into OTP that uses different pins.

8.3 Boot from SPI slave

If set to boot from SPI slave, the processor enables the three pins specified in Figure 12 and expects a boot image to be clocked in. The supported clock polarity and phase are 0/0 and 1/1.

Figure 12:
SPI slave pins

Pin	Signal	Description
X0D00	SS	Slave Select
X0D10	SCLK	Clock
X0D11	MOSI	Master Out Slave In (Data)

The xCORE Tile expects each byte to be transferred with the *least-significant bit first*. The pins used for SPI boot are hardcoded in the boot ROM and cannot be changed. If required, an SPI boot program can be burned into OTP that uses different pins.

8.4 Boot from xConnect Link

If set to boot from an xConnect Link, the processor enables its link(s) around 2 us after the boot process starts. Enabling the Link switches off the pull-down

resistors on the link, drives all the TX wires low (the initial state for the Link), and monitors the RX pins for boot-traffic; they must be low at this stage. If the internal pull-down is too weak to drain any residual charge, external pull-downs of 10K may be required on those pins.

The boot-rom on the core will then:

1. Allocate channel-end 0.
2. Input a word on channel-end 0. It will use this word as a channel to acknowledge the boot. Provide the null-channel-end 0x0000FF02 if no acknowledgment is required.
3. Input the boot image specified above, including the CRC.
4. Input an END control token.
5. Output an END control token to the channel-end received in step 2.
6. Free channel-end 0.
7. Jump to the loaded code.

8.5 Boot from OTP

If an xCORE tile is set to use secure boot (see Figure 8), the boot image is read from address 0 of the OTP memory in the tile's security module.

This feature can be used to implement a secure bootloader which loads an encrypted image from external flash, decrypts and CRC checks it with the processor, and discontinues the boot process if the decryption or CRC check fails. XMOS provides a default secure bootloader that can be written to the OTP along with secret decryption keys.

Each tile has its own individual OTP memory, and hence some tiles can be booted from OTP while others are booted from SPI or the channel interface. This enables systems to be partially programmed, dedicating one or more tiles to perform a particular function, leaving the other tiles user-programmable.

8.6 Security register

The security register enables security features on the xCORE tile. The features shown in Figure 13 provide a strong level of protection and are sufficient for providing strong IP security.

9 Memory

9.1 OTP

Each xCORE Tile integrates 8 KB one-time programmable (OTP) memory along with a security register that configures system wide security features. The OTP holds

Feature	Bit	Description
Disable JTAG	0	The JTAG interface is disabled, making it impossible for the tile state or memory content to be accessed via the JTAG interface.
Disable Link access	1	Other tiles are forbidden access to the processor state via the system switch. Disabling both JTAG and Link access transforms an xCORE Tile into a “secure island” with other tiles free for non-secure user application code.
Secure Boot	5	The xCORE Tile is forced to boot from address 0 of the OTP, allowing the xCORE Tile boot ROM to be bypassed (<i>see §8</i>).
Redundant rows	7	Enables redundant rows in OTP.
Sector Lock 0	8	Disable programming of OTP sector 0.
Sector Lock 1	9	Disable programming of OTP sector 1.
Sector Lock 2	10	Disable programming of OTP sector 2.
Sector Lock 3	11	Disable programming of OTP sector 3.
OTP Master Lock	12	Disable OTP programming completely: disables updates to all sectors and security register.
Disable JTAG-OTP	13	Disable all (read & write) access from the JTAG interface to this OTP.
Disable Global Debug	14	Disables access to the DEBUG_N pin.
	21..15	General purpose software accessible security register available to end-users.
	31..22	General purpose user programmable JTAG UserID code extension.

Figure 13:
Security register features

data in four sectors each containing 512 rows of 32 bits which can be used to implement secure bootloaders and store encryption keys. Data for the security register is loaded from the OTP on power up. All additional data in OTP is copied from the OTP to SRAM and executed first on the processor.

The OTP memory is programmed using three special I/O ports: the OTP address port is a 16-bit port with resource ID 0x100200, the OTP data is written via a 32-bit port with resource ID 0x200100, and the OTP control is on a 16-bit port with ID 0x100300. Programming is performed through `libotp` and `xburn`.

9.2 SRAM

Each xCORE Tile integrates a single 256KBSRAM bank for both instructions and data. All internal memory is 32 bits wide, and instructions are either 16-bit or 32-bit. Byte (8-bit), half-word (16-bit) or word (32-bit) accesses are supported and are executed within one tile clock cycle. There is no dedicated external memory interface, although data memory can be expanded through appropriate use of the ports.

10 USB PHY

The USB PHY provides High-Speed and Full-Speed, device, host, and on-the-go functionality. The PHY is configured through a set of peripheral registers (Appendix F), and data is communicated through ports on the digital node. A library, libxud_s.a, is provided to implement USB device functionality.

This device has two USB PHYs. One PHY is part of Node 0 and can be connected to either Tile 0 or Tile 1; it uses pins USB_DM, USB_DP, USB_VUBS, USB_ID, and USB_RTUNE. The other PHY is part of Node 2 and can be connected to either Tile 2 or Tile 3; it uses pins USB_2_DM, USB_2_DP, USB_2_VUBS, USB_2_ID, and USB_2_RTUNE. Below we present the configuration of the USB PHY connected to Node 0 (Tiles 0 and 1) an identical configuration is available for Node 2.

The USB PHY is connected to the ports on Tile 0 and Tile 1 as shown in Figure 14. When the USB PHY is enabled on Tile 0, the ports shown can on Tile 0 only be used with the USB PHY. When the USB PHY is enabled on Tile 1, then the ports shown can on Tile 1 only be used with the USB PHY. All other IO pins and ports are unaffected. The USB PHY should not be enabled on both tiles.

An external resistor of 43.2 ohm (1% tolerance) should connect USB_RTUNE to ground, as close as possible to the device.

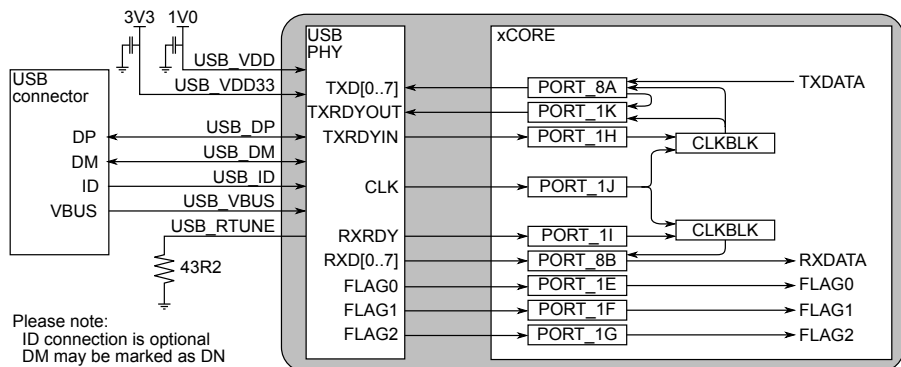

Figure 14:
USB port
functions

Figure 14 shows how two clock blocks can be used to clock the USB ports. One clock block for the TXDATA path, and one clock block for the RXDATA path. Details on how to connect those ports are documented in an application note on USB for xCORE-200.

10.1 Logical Core Requirements

The XMOS XUD software component runs in a single logical core with endpoint and application cores communicating with it via a combination of channel communication and shared memory variables.

Each IN (host requests data from device) or OUT (data transferred from host to device) endpoint requires one logical core.

11 JTAG

The JTAG module can be used for loading programs, boundary scan testing, in-circuit source-level debugging and programming the OTP memory.

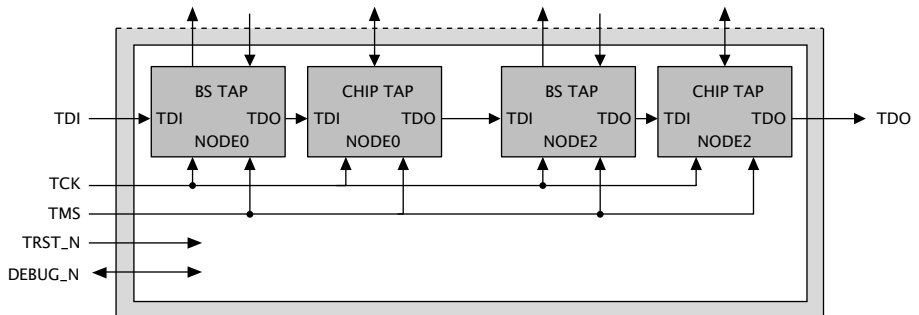

Figure 15:
JTAG chain structure

The JTAG chain structure is illustrated in Figure 15. Directly after reset, two TAP controllers are present in the JTAG chain for each xCORE Tile: the boundary scan TAP and the chip TAP. The boundary scan TAP is a standard 1149.1 compliant TAP that can be used for boundary scan of the I/O pins. The chip TAP provides access into the xCORE Tile, switch and OTP for loading code and debugging.

The TRST_N pin must be asserted low during and after power up for 100 ns. If JTAG is not required, the TRST_N pin can be tied to ground to hold the JTAG module in reset.

The DEBUG_N pin is used to synchronize the debugging of multiple xCORE Tiles. This pin can operate in both output and input mode. In output mode and when configured to do so, DEBUG_N is driven low by the device when the processor hits a debug break point. Prior to this point the pin will be tri-stated. In input mode and when configured to do so, driving this pin low will put the xCORE Tile into debug mode. Software can set the behavior of the xCORE Tile based on this pin. This pin should have an external pull up of 4K7-47KΩ or left not connected in single core applications.

The JTAG device identification register can be read by using the IDCODE instruction. Its contents are specified in Figure 16.

Figure 16:
IDCODE return value

Bit31	Device Identification Register																												Bit0				
Version				Part Number												Manufacturer Identity												1					
0	0	0	0	0	0	0	0	0	0	0	0	0	0	0	0	0	0	0	1	1	0	0	1	1	0	0	1	1	0	0	1	1	1
0				0				0				0				6				6				3				3					

The JTAG usercode register can be read by using the USERCODE instruction. Its contents are specified in Figure 17. The OTP User ID field is read from bits [22:31] of the security register on xCORE Tile 0, *see* §9.1 (all zero on unprogrammed devices).

Figure 17:
USERCODE
return value

Bit31		Usercode Register																								Bit0													
OTP User ID										Unused				Silicon Revision																									
0	0	0	0	0	0	0	0	0	0	0	0	0	0	0	0	0	0	0	0	0	0	0	0	0	0	0	0	0	0	0	0	0	0	0	0	0	0	0	0
0										2				8										0															

12 Board Integration

The device has the following power supply pins:

- ▶ VDD pins for the xCORE Tile, including USB_VDD and USB_2_VDD pins that power the USB PHY
- ▶ VDDIO pins for the I/O lines
- ▶ PLL_AVDD pins for the PLL
- ▶ OTP_VCC pins for the OTP
- ▶ USB_VDD33 and USB_2_VDD33 pins for the analogue supply to the USB-PHY

Several pins of each type are provided to minimize the effect of inductance within the package, all of which must be connected. The power supplies must be brought up monotonically and input voltages must not exceed specification at any time.

The VDD supply must ramp from 0 V to its final value within 10 ms to ensure correct startup.

The VDDIO and OTP_VCC supply must ramp to its final value before VDD reaches 0.4 V.

The PLL_AVDD supply should be separated from the other noisier supplies on the board. The PLL requires a very clean power supply, and a low pass filter (for example, a 2.2 Ω resistor and 100 nF multi-layer ceramic capacitor) is recommended on this pin.

The following ground pins are provided:

- ▶ PLL_AGND for PLL_AVDD
- ▶ GND for all other supplies

All ground pins must be connected directly to the board ground.

The VDD and VDDIO supplies should be decoupled close to the chip by several 100 nF low inductance multi-layer ceramic capacitors between the supplies and GND (for example, 100nF 0402 for every other supply pin). The ground side of the decoupling capacitors should have as short a path back to the GND pins as

possible. A bulk decoupling capacitor of at least 10 μF should be placed on each of these supplies.

RST_N is an active-low asynchronous-assertion global reset signal. Following a reset, the PLL re-establishes lock after which the device boots up according to the boot mode (see §8). RST_N and must be asserted low during and after power up for 100 ns.

12.1 USB connections

USB_VBUS should be connected to the VBUS pin of the USB connector. A 2.2 μF capacitor to ground is required on the VBUS pin. A ferrite bead may be used to reduce HF noise.

For self-powered systems, a bleeder resistor may be required to stop VBUS from floating when no USB cable is attached.

USB_DP and USB_DN should be connected to the USB connector. USB_ID does not need to be connected.

12.2 USB signal routing and placement

The USB_DP and USB_DN lines are the positive and negative data polarities of a high speed USB signal respectively. Their high-speed differential nature implies that they must be coupled and properly isolated. The board design must ensure that the board traces for USB_DP and USB_DN are tightly matched. In addition, according to the USB 2.0 specification, the USB_DP and USB_DN differential impedance must be 90 Ω .

Figure 18:
USB trace separation showing a low speed signal, two differential pairs and a high-speed clock

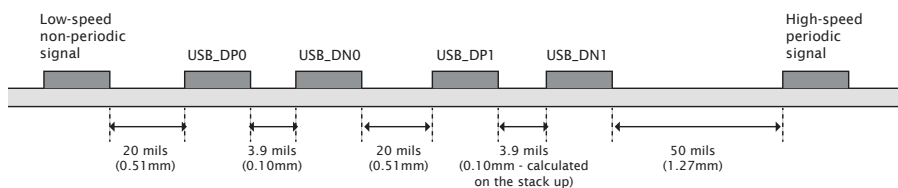

12.2.1 General routing and placement guidelines

The following guidelines will help to avoid signal quality and EMI problems on high speed USB designs. They relate to a four-layer (Signal, GND, Power, Signal) PCB.

For best results, most of the routing should be done on the top layer (assuming the USB connector and XU224-1024-FB374 are on the top layer) closest to GND. Reference planes should be below the transmission lines in order to maintain control of the trace impedance.

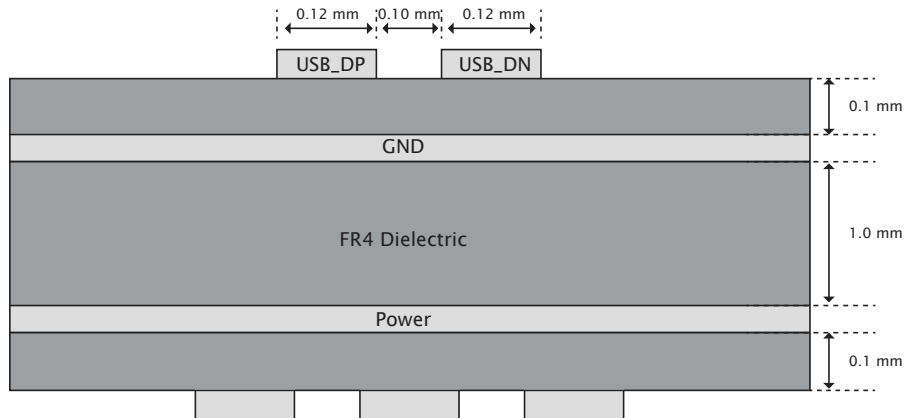

Figure 19:
Example USB
board stack

We recommend that the high-speed clock and high-speed USB differential pairs are routed first before any other routing. When routing high speed USB signals, the following guidelines should be followed:

- ▶ High speed differential pairs should be routed together.
- ▶ High-speed USB signal pair traces should be trace-length matched. Maximum trace-length mismatch should be no greater than 4mm.
- ▶ Ensure that high speed signals (clocks, USB differential pairs) are routed as far away from off-board connectors as possible.
- ▶ High-speed clock and periodic signal traces that run parallel should be at least 1.27mm away from USB_DP/USB_DN (see Figure 18).
- ▶ Low-speed and non-periodic signal traces that run parallel should be at least 0.5mm away from USB_DP/USB_DN (see Figure 18).
- ▶ Route high speed USB signals on the top of the PCB wherever possible.
- ▶ Route high speed USB traces over continuous power planes, with no breaks. If a trade-off must be made, changing signal layers is preferable to crossing plane splits.
- ▶ Follow the $20 \times h$ rule; keep traces $20 \times h$ (the height above the power plane) away from the edge of the power plane.
- ▶ Use a minimum of vias in high speed USB traces.
- ▶ Avoid corners in the trace. Where necessary, rather than turning through a 90 degree angle, use two 45 degree turns or an arc.
- ▶ DO NOT route USB traces near clock sources, clocked circuits or magnetic devices.

- ▶ Avoid stubs on high speed USB signals.

12.3 Land patterns and solder stencils

The package is a 374 ball Fine Ball Grid Array (FBGA) on a 0.8 mm pitch.

The land patterns and solder stencils will depend on the PCB manufacturing process. We recommend you design them with using the IPC specifications "*Generic Requirements for Surface Mount Design and Land Pattern Standards*" [IPC-7351B](#). This standard aims to achieve desired targets of heel, toe and side fillets for solder-joints. The mechanical drawings in Section 14 specify the dimensions and tolerances.

12.4 Ground and Thermal Vias

Vias next to each ground ball into the ground plane of the PCB are recommended for a low inductance ground connection and good thermal performance.

12.5 Moisture Sensitivity

XMOS devices are, like all semiconductor devices, susceptible to moisture absorption. When removed from the sealed packaging, the devices slowly absorb moisture from the surrounding environment. If the level of moisture present in the device is too high during reflow, damage can occur due to the increased internal vapour pressure of moisture. Example damage can include bond wire damage, die lifting, internal or external package cracks and/or delamination.

All XMOS devices are Moisture Sensitivity Level (MSL) 3 - devices have a shelf life of 168 hours between removal from the packaging and reflow, provided they are stored below 30C and 60% RH. If devices have exceeded these values or an included moisture indicator card shows excessive levels of moisture, then the parts should be baked as appropriate before use. This is based on information from *Joint IPC/JEDEC Standard For Moisture/Reflow Sensitivity Classification For Nonhermetic Solid State Surface-Mount Devices* [J-STD-020](#) Revision D.

13 DC and Switching Characteristics

13.1 Operating Conditions

Symbol	Parameter	MIN	TYP	MAX	UNITS	Notes
VDD	Tile DC supply voltage	0.95	1.00	1.05	V	
VDDIO	I/O supply voltage	2.30	3.30	3.60	V	
VDDIOT 3v3	I/O supply voltage	3.135	3.30	3.465	V	
VDDIOT 2v5	I/O supply voltage	2.375	2.50	2.625	V	
USB_VDD	USB tile DC supply voltage	0.95	1.00	1.05	V	
VDD33	Peripheral supply	3.135	3.30	3.465	V	
PLL_AVDD	PLL analog supply	0.95	1.00	1.05	V	
CI	xCORE Tile I/O load capacitance			25	pF	
Ta	Ambient operating temperature (Commercial)	0		70	°C	
	Ambient operating temperature (Industrial)	-40		85	°C	
Tj	Junction temperature			125	°C	
Tstg	Storage temperature	-65		150	°C	

Figure 20:
Operating conditions

13.2 DC Characteristics, VDDIO=3V3

Symbol	Parameter	MIN	TYP	MAX	UNITS	Notes
V(IH)	Input high voltage	2.00		3.60	V	A
V(IL)	Input low voltage	-0.30		0.70	V	A
V(OH)	Output high voltage	2.20			V	B, C
V(OL)	Output low voltage			0.40	V	B, C
I(PU)	Internal pull-up current (Vin=0V)	-100			μA	D
I(PD)	Internal pull-down current (Vin=3.3V)			100	μA	D
I(LC)	Input leakage current	-10		10	μA	

Figure 21:
DC characteristics

A All pins except power supply pins.

B Pins X1D40, X1D41, X1D42, X1D43, X1D26, X1D27, X3D40, X3D41, X3D42, X3D43, X3D26, and X3D27 are nominal 8 mA drivers, the remainder of the general-purpose I/Os are 4 mA.

C Measured with 4 mA drivers sourcing 4 mA, 8 mA drivers sourcing 8 mA.

D Used to guarantee logic state for an I/O when high impedance. The internal pull-ups/pull-downs should not be used to pull external circuitry. In order to pull the pin to the opposite state, a 4K7 resistor is recommended to overcome the internal pull current.

Figure 22:
Typical internal pull-down and pull-up currents

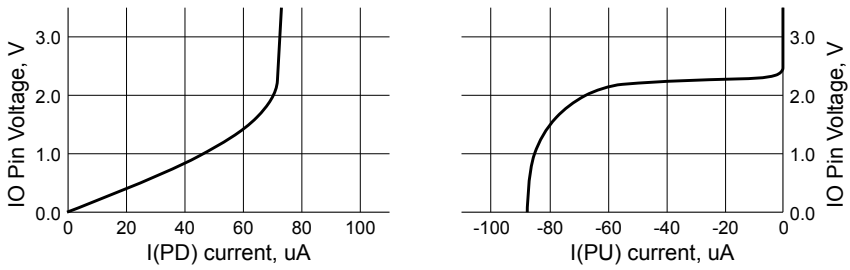

13.3 ESD Stress Voltage

Figure 23:
ESD stress voltage

Symbol	Parameter	MIN	TYP	MAX	UNITS	Notes
HBM	Human body model	-2.00		2.00	KV	
CDM	Charged Device Model	-500		500	V	

13.4 Reset Timing

Figure 24:
Reset timing

Symbol	Parameters	MIN	TYP	MAX	UNITS	Notes
T(RST)	Reset pulse width	5			μs	
T(INIT)	Initialization time			150	μs	A

A Shows the time taken to start booting after RST_N has gone high.

13.5 Power Consumption

Figure 25:
xCORE Tile
currents

Symbol	Parameter	MIN	TYP	MAX	UNITS	Notes
I(DDCQ)	Quiescent VDD current		90		mA	A, B, C
PD	Tile power dissipation		325		μW/MIPS	A, D, E, F
IDD	Active VDD current		1140	1400	mA	A, G
I(ADDPLL)	PLL_AVDD current		5	7	mA	H
I(VDD33)	VDD33 current		53.4		mA	I
I(USB_VDD)	USB_VDD current		16.6		mA	J

A Use for budgetary purposes only.

B Assumes typical tile and I/O voltages with no switching activity.

C Includes PLL current.

D Assumes typical tile and I/O voltages with nominal switching activity.

E Assumes 1 MHz = 1 MIPS.

F PD(TYP) value is the usage power consumption under typical operating conditions.

G Measurement conditions: VDD = 1.0 V, VDDIO = 3.3 V, 25 °C, 500 MHz, average device resource usage.

H PLL_AVDD = 1.0 V

I HS mode transmitting while driving all 0's data (constant JKJK on DP/DM). Loading of 10 pF. Transfers do not include any interpacket delay.

J HS receive mode; no traffic.



The tile power consumption of the device is highly application dependent and should be used for budgetary purposes only.

More detailed power analysis can be found in the XS1-U Power Consumption document,

13.6 Clock

Figure 26:
Clock

Symbol	Parameter	MIN	TYP	MAX	UNITS	Notes
f	Frequency	3.25	24	100	MHz	
SR	Slew rate	0.10			V/ns	
TJ(LT)	Long term jitter (pk-pk)			2	%	A
f(MAX)	Processor clock frequency			500	MHz	B

A Percentage of CLK period.

B Assumes typical tile and I/O voltages with nominal activity.

Further details can be found in the XS1-U Clock Frequency Control document,

13.7 xCORE Tile I/O AC Characteristics

Figure 27:
I/O AC characteristics

Symbol	Parameter	MIN	TYP	MAX	UNITS	Notes
T(XOVALID)	Input data valid window	8			ns	
T(XOINVALID)	Output data invalid window	9			ns	
T(XIFMAX)	Rate at which data can be sampled with respect to an external clock			60	MHz	

The input valid window parameter relates to the capability of the device to capture data input to the chip with respect to an external clock source. It is calculated as the sum of the input setup time and input hold time with respect to the external clock as measured at the pins. The output invalid window specifies the time for which an output is invalid with respect to the external clock. Note that these parameters are specified as a window rather than absolute numbers since the device provides functionality to delay the incoming clock with respect to the incoming data.

Information on interfacing to high-speed synchronous interfaces can be found in the XS1 Port I/O Timing document, [X5821](#).

13.8 xConnect Link Performance

Figure 28:
Link performance

Symbol	Parameter	MIN	TYP	MAX	UNITS	Notes
B(2blinkP)	2b link bandwidth (packetized)			87	MBit/s	A, B
B(5blinkP)	5b link bandwidth (packetized)			217	MBit/s	A, B
B(2blinkS)	2b link bandwidth (streaming)			100	MBit/s	B
B(5blinkS)	5b link bandwidth (streaming)			250	MBit/s	B

A Assumes 32-byte packet in 3-byte header mode. Actual performance depends on size of the header and payload.

B 7.5 ns symbol time.

The asynchronous nature of links means that the relative phasing of CLK clocks is not important in a multi-clock system, providing each meets the required stability criteria.

13.9 JTAG Timing

Figure 29:
JTAG timing

Symbol	Parameter	MIN	TYP	MAX	UNITS	Notes
f(TCK_D)	TCK frequency (debug)			18	MHz	
f(TCK_B)	TCK frequency (boundary scan)			10	MHz	
T(SETUP)	TDO to TCK setup time	5			ns	A
T(HOLD)	TDO to TCK hold time	5			ns	A
T(DELAY)	TCK to output delay			15	ns	B

A Timing applies to TMS and TDI inputs.

B Timing applies to TDO output from negative edge of TCK.

All JTAG operations are synchronous to TCK apart from the global asynchronous reset TRST_N.

14 Package Information

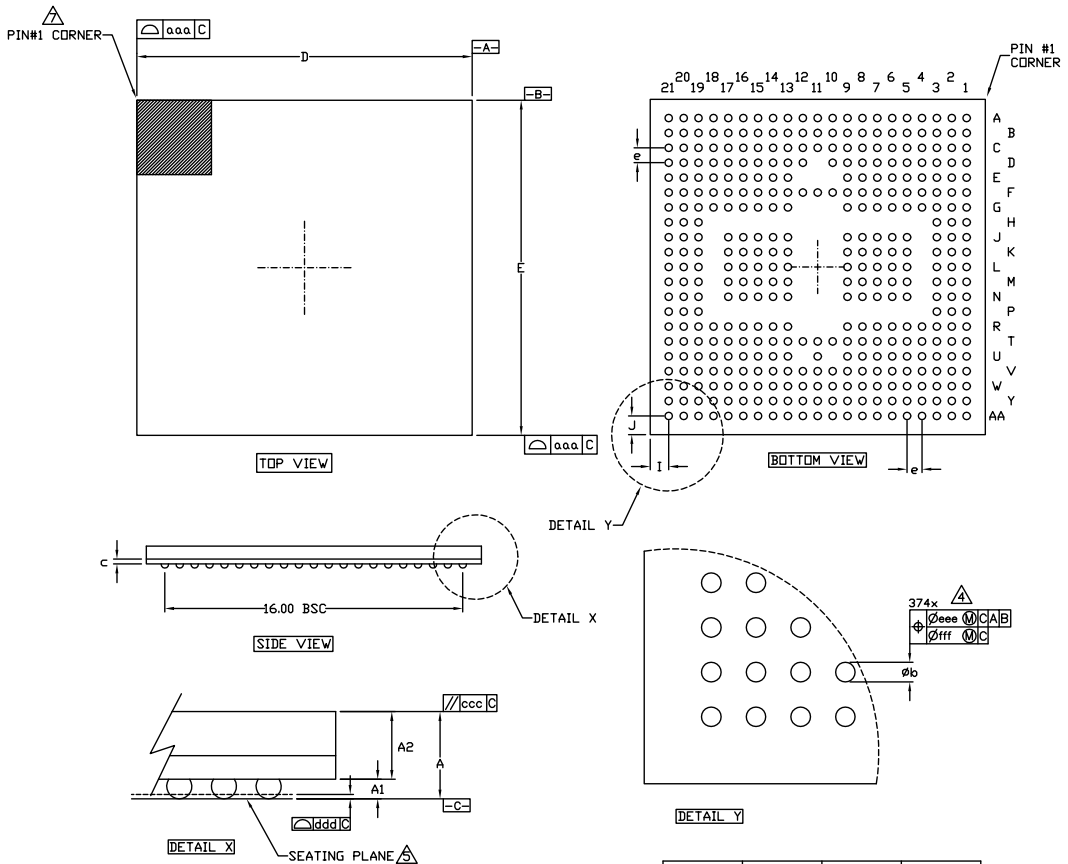

NOTE:

1. ALL DIMENSIONS ARE IN MILLIMETERS.
2. "e" REPRESENTS THE BASIC SOLDER BALL GRID PITCH.
3. "M" REPRESENTS THE MAXIMUM SOLDER BALL MATRIX SIZE.
4. DIMENSIONS "b" IS MEASURED AT THE MAXIMUM SOLDER BALL DIAMETER PARALLEL TO PRIMARY DATUM [C].
5. PRIMARY DATUM [C] AND SEATING PLANE ARE DESIGNED BY THE SPHERICAL CROWNS OF THE SOLDER BALLS.
6. DIMENSIONING AND TOLERANCING PER ASME Y14.5M-1994
7. A1 CORNER MUST BE IDENTIFIED BY LASER MARK.

SYMBOL	MIN.	NOM.	MAX.
A	1.16	1.26	1.36
A1	0.25	0.30	0.35
A2	0.91	0.96	1.01
D	17.90	18.00	18.10
E	17.90	18.00	18.10
I		1.00 REF.	
J		1.00 REF.	
M		21x21<DEPOPULATED>	
aaa			0.15
ccc			0.20
ddd			0.10
eee			0.15
fff			0.08
b	0.35	0.40	0.45
e		0.80 BSC.	
c		0.26 REF.	

14.1 Part Marking

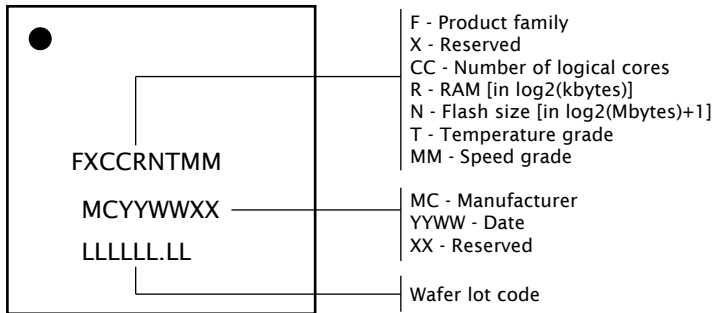

Figure 30:
Part marking scheme

15 Ordering Information

Figure 31:
Orderable part numbers

Product Code	Marking	Qualification	Speed Grade
XU224-1024-FB374-C40	U124A0C40	Commercial	2000 MIPS
XU224-1024-FB374-I40	U124A0I40	Industrial	2000 MIPS

Appendices

A Configuration of the XU224-1024-FB374

The device is configured through banks of registers, as shown in Figure 32.

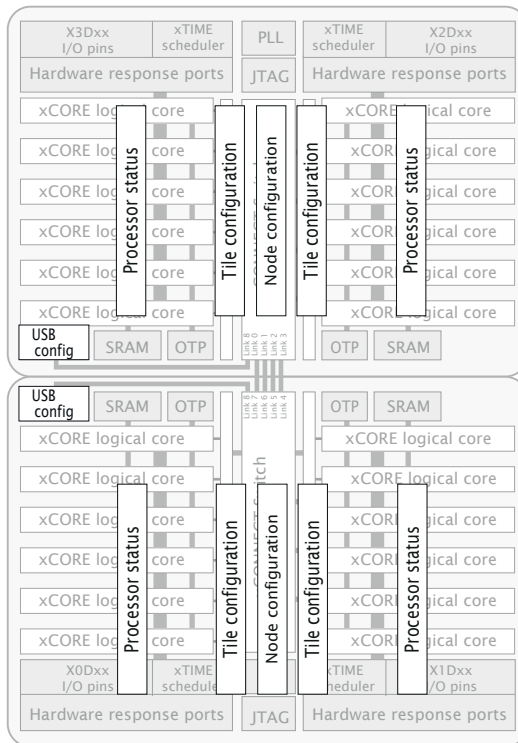

Figure 32:
Registers

The following communication sequences specify how to access those registers. Any messages transmitted contain the most significant 24 bits of the channel-end to which a response is to be sent. This comprises the node-identifier and the channel number within the node. If no response is required on a write operation, supply 24-bits with the last 8-bits set, which suppresses the reply message. Any multi-byte data is sent most significant byte first.

A.1 Accessing a processor status register

The processor status registers are accessed directly from the processor instruction set. The instructions GETPS and SETPS read and write a word. The register number should be translated into a processor-status resource identifier by shifting the register number left 8 places, and ORing it with 0x0B. Alternatively, the functions `getps(reg)` and `setps(reg, value)` can be used from XC.

A.2 Accessing an xCORE Tile configuration register

xCORE Tile configuration registers can be accessed through the interconnect using the functions `write_tile_config_reg(tileref, ...)` and `read_tile_config_reg(tile ↪ ref, ...)`, where `tileref` is the name of the xCORE Tile, e.g. `tile[1]`. These functions implement the protocols described below.

Instead of using the functions above, a channel-end can be allocated to communicate with the xCORE tile configuration registers. The destination of the channel-end should be set to `0xnnnnC20C` where `nnnnn` is the tile-identifier.

A write message comprises the following:

control-token 192	24-bit response channel-end identifier	16-bit register number	32-bit data	control-token 1
----------------------	---	---------------------------	----------------	--------------------

The response to a write message comprises either control tokens 3 and 1 (for success), or control tokens 4 and 1 (for failure).

A read message comprises the following:

control-token 193	24-bit response channel-end identifier	16-bit register number	control-token 1
----------------------	---	---------------------------	--------------------

The response to the read message comprises either control token 3, 32-bit of data, and control-token 1 (for success), or control tokens 4 and 1 (for failure).

A.3 Accessing node configuration

Node configuration registers can be accessed through the interconnect using the functions `write_node_config_reg(device, ...)` and `read_node_config_reg(device, ↪ ...)`, where `device` is the name of the node. These functions implement the protocols described below.

Instead of using the functions above, a channel-end can be allocated to communicate with the node configuration registers. The destination of the channel-end should be set to `0xnnnnC30C` where `nnnn` is the node-identifier.

A write message comprises the following:

control-token 192	24-bit response channel-end identifier	16-bit register number	32-bit data	control-token 1
----------------------	---	---------------------------	----------------	--------------------

The response to a write message comprises either control tokens 3 and 1 (for success), or control tokens 4 and 1 (for failure).

A read message comprises the following:

control-token 193	24-bit response channel-end identifier	16-bit register number	control-token 1
----------------------	---	---------------------------	--------------------

The response to a read message comprises either control token 3, 32-bit of data, and control-token 1 (for success), or control tokens 4 and 1 (for failure).

A.4 Accessing a register of an analogue peripheral

Peripheral registers can be accessed through the interconnect using the functions `write_periph_32(device, peripheral, ...)`, `read_periph_32(device, peripheral, ...)`, `write_periph_8(device, peripheral, ...)`, and `read_periph_8(device, peripheral, ...)`; where `device` is the name of the analogue device, and `peripheral` is the number of the peripheral. These functions implement the protocols described below.

A channel-end should be allocated to communicate with the configuration registers. The destination of the channel-end should be set to `0xnnnnpp02` where `nnnn` is the node-identifier and `pp` is the peripheral identifier.

A write message comprises the following:

control-token 36	24-bit response channel-end identifier	8-bit register number	8-bit size	data	control-token 1
---------------------	---	--------------------------	---------------	------	--------------------

The response to a write message comprises either control tokens 3 and 1 (for success), or control tokens 4 and 1 (for failure).

A read message comprises the following:

control-token 37	24-bit response channel-end identifier	8-bit register number	8-bit size	control-token 1
---------------------	---	--------------------------	---------------	--------------------

The response to the read message comprises either control token 3, data, and control-token 1 (for success), or control tokens 4 and 1 (for failure).

B Processor Status Configuration

The processor status control registers can be accessed directly by the processor using processor status reads and writes (use `getps(reg)` and `setps(reg,value)` for reads and writes).

Number	Perm	Description
0x00	RW	RAM base address
0x01	RW	Vector base address
0x02	RW	xCORE Tile control
0x03	RO	xCORE Tile boot status
0x05	RW	Security configuration
0x06	RW	Ring Oscillator Control
0x07	RO	Ring Oscillator Value
0x08	RO	Ring Oscillator Value
0x09	RO	Ring Oscillator Value
0x0A	RO	Ring Oscillator Value
0x0C	RO	RAM size
0x10	DRW	Debug SSR
0x11	DRW	Debug SPC
0x12	DRW	Debug SSP
0x13	DRW	DGETREG operand 1
0x14	DRW	DGETREG operand 2
0x15	DRW	Debug interrupt type
0x16	DRW	Debug interrupt data
0x18	DRW	Debug core control
0x20 .. 0x27	DRW	Debug scratch
0x30 .. 0x33	DRW	Instruction breakpoint address
0x40 .. 0x43	DRW	Instruction breakpoint control
0x50 .. 0x53	DRW	Data watchpoint address 1
0x60 .. 0x63	DRW	Data watchpoint address 2
0x70 .. 0x73	DRW	Data breakpoint control register
0x80 .. 0x83	DRW	Resources breakpoint mask
0x90 .. 0x93	DRW	Resources breakpoint value
0x9C .. 0x9F	DRW	Resources breakpoint control register

Figure 33:
Summary

B.1 RAM base address: 0x00

This register contains the base address of the RAM. It is initialized to 0x00040000.

0x00: RAM base address	Bits	Perm	Init	Description
	31:2	RW		Most significant 16 bits of all addresses.
	1:0	RO	-	Reserved

B.2 Vector base address: 0x01

Base address of event vectors in each resource. On an interrupt or event, the 16 most significant bits of the destination address are provided by this register; the least significant 16 bits come from the event vector.

0x01: Vector base address	Bits	Perm	Init	Description
	31:18	RW		The event and interrupt vectors.
	17:0	RO	-	Reserved

B.3 xCORE Tile control: 0x02

Register to control features in the xCORE tile

Bits	Perm	Init	Description
31:26	RO	-	Reserved
25:18	RW	0	RGMIITX data delay value (in PLL output cycle increments)
17:9	RW	0	RGMIITX clock divider value. TX clk rises when counter (clocked by PLL output) reaches this value and falls when counter reaches (value»1). Value programmed into this field should be actual divide value required minus 1
8	RW	0	Enable RGMIIT interface periph ports
7:6	RO	-	Reserved
5	RW	0	Select the dynamic mode (1) for the clock divider when the clock divider is enabled. In dynamic mode the clock divider is only activated when all active threads are paused. In static mode the clock divider is always enabled.
4	RW	0	Enable the clock divider. This divides the output of the PLL to facilitate one of the low power modes.
3	RO	-	Reserved
2	RW		Select between UTMI (1) and ULPI (0) mode.
1	RW		Enable the ULPI Hardware support module
0	RO	-	Reserved

0x02:
xCORE Tile
control

B.4 xCORE Tile boot status: 0x03

This read-only register describes the boot status of the xCORE tile.

Bits	Perm	Init	Description
31:24	RO	-	Reserved
23:16	RO		Processor number.
15:9	RO	-	Reserved
8	RO		Overwrite BOOT_MODE.
7:6	RO	-	Reserved
5	RO		Indicates if core1 has been powered off
4	RO		Cause the ROM to not poll the OTP for correct read levels
3	RO		Boot ROM boots from RAM
2	RO		Boot ROM boots from JTAG
1:0	RO		The boot PLL mode pin value.

0x03:
xCORE Tile
boot status

B.5 Security configuration: 0x05

Copy of the security register as read from OTP.

0x05:
Security
configuration

Bits	Perm	Init	Description
31	RW		Disables write permission on this register
30:15	RO	-	Reserved
14	RW		Disable access to XCore's global debug
13	RO	-	Reserved
12	RW		lock all OTP sectors
11:8	RW		lock bit for each OTP sector
7	RW		Enable OTP redundancy
6	RO	-	Reserved
5	RW		Override boot mode and read boot image from OTP
4	RW		Disable JTAG access to the PLL/BOOT configuration registers
3:1	RO	-	Reserved
0	RW		Disable access to XCore's JTAG debug TAP

B.6 Ring Oscillator Control: 0x06

There are four free-running oscillators that clock four counters. The oscillators can be started and stopped using this register. The counters should only be read when the ring oscillator has been stopped for at least 10 core clock cycles (this can be achieved by inserting two nop instructions between the SETPS and GETPS). The counter values can be read using four subsequent registers. The ring oscillators are asynchronous to the xCORE tile clock and can be used as a source of random bits.

0x06:
Ring
Oscillator
Control

Bits	Perm	Init	Description
31:2	RO	-	Reserved
1	RW	0	Core ring oscillator enable.
0	RW	0	Peripheral ring oscillator enable.

B.7 Ring Oscillator Value: 0x07

This register contains the current count of the xCORE Tile Cell ring oscillator. This value is not reset on a system reset.

0x07:
Ring
Oscillator
Value

Bits	Perm	Init	Description
31:16	RO	-	Reserved
15:0	RO	0	Ring oscillator Counter data.

B.8 Ring Oscillator Value: 0x08

This register contains the current count of the xCORE Tile Wire ring oscillator. This value is not reset on a system reset.

0x08:
Ring
Oscillator
Value

Bits	Perm	Init	Description
31:16	RO	-	Reserved
15:0	RO	0	Ring oscillator Counter data.

B.9 Ring Oscillator Value: 0x09

This register contains the current count of the Peripheral Cell ring oscillator. This value is not reset on a system reset.

0x09:
Ring
Oscillator
Value

Bits	Perm	Init	Description
31:16	RO	-	Reserved
15:0	RO	0	Ring oscillator Counter data.

B.10 Ring Oscillator Value: 0x0A

This register contains the current count of the Peripheral Wire ring oscillator. This value is not reset on a system reset.

0x0A:
Ring
Oscillator
Value

Bits	Perm	Init	Description
31:16	RO	-	Reserved
15:0	RO	0	Ring oscillator Counter data.

B.11 RAM size: 0x0C

The size of the RAM in bytes

0x0C:
RAM size

Bits	Perm	Init	Description
31:2	RO		Most significant 16 bits of all addresses.
1:0	RO	-	Reserved

B.12 Debug SSR: 0x10

This register contains the value of the SSR register when the debugger was called.

0x10:
Debug SSR

Bits	Perm	Init	Description
31:11	RO	-	Reserved
10	DRW		Address space identifier
9	DRW		Determines the issue mode (DI bit) upon Kernel Entry after Exception or Interrupt.
8	RO		Determines the issue mode (DI bit).
7	DRW		When 1 the thread is in fast mode and will continually issue.
6	DRW		When 1 the thread is paused waiting for events, a lock or another resource.
5	RO	-	Reserved
4	DRW		1 when in kernel mode.
3	DRW		1 when in an interrupt handler.
2	DRW		1 when in an event enabling sequence.
1	DRW		When 1 interrupts are enabled for the thread.
0	DRW		When 1 events are enabled for the thread.

B.13 Debug SPC: 0x11

This register contains the value of the SPC register when the debugger was called.

0x11:
Debug SPC

Bits	Perm	Init	Description
31:0	DRW		Value.

B.14 Debug SSP: 0x12

This register contains the value of the SSP register when the debugger was called.

0x12: Debug SSP	Bits	Perm	Init	Description
	31:0	DRW		Value.

B.15 DGETREG operand 1: 0x13

The resource ID of the logical core whose state is to be read.

0x13: DGETREG operand 1	Bits	Perm	Init	Description
	31:8	RO	-	Reserved
	7:0	DRW		Thread number to be read

B.16 DGETREG operand 2: 0x14

Register number to be read by DGETREG

0x14: DGETREG operand 2	Bits	Perm	Init	Description
	31:5	RO	-	Reserved
	4:0	DRW		Register number to be read

B.17 Debug interrupt type: 0x15

Register that specifies what activated the debug interrupt.

0x15: Debug interrupt type	Bits	Perm	Init	Description
	31:18	RO	-	Reserved
	17:16	DRW		Number of the hardware breakpoint/watchpoint which caused the interrupt (always 0 for =HOST= and =DCALL=). If multiple breakpoints/watchpoints trigger at once, the lowest number is taken.
	15:8	DRW		Number of thread which caused the debug interrupt (always 0 in the case of =HOST=).
	7:3	RO	-	Reserved
	2:0	DRW	0	Indicates the cause of the debug interrupt 1: Host initiated a debug interrupt through JTAG 2: Program executed a DCALL instruction 3: Instruction breakpoint 4: Data watch point 5: Resource watch point

B.18 Debug interrupt data: 0x16

On a data watchpoint, this register contains the effective address of the memory operation that triggered the debugger. On a resource watchpoint, it contains the resource identifier.

0x16:
Debug
interrupt data

Bits	Perm	Init	Description
31:0	DRW		Value.

B.19 Debug core control: 0x18

This register enables the debugger to temporarily disable logical cores. When returning from the debug interrupts, the cores set in this register will not execute. This enables single stepping to be implemented.

0x18:
Debug core
control

Bits	Perm	Init	Description
31:8	RO	-	Reserved
7:0	DRW		1-hot vector defining which threads are stopped when not in debug mode. Every bit which is set prevents the respective thread from running.

B.20 Debug scratch: 0x20 .. 0x27

A set of registers used by the debug ROM to communicate with an external debugger, for example over JTAG. This is the same set of registers as the [Debug Scratch registers in the xCORE tile configuration](#).

0x20 .. 0x27:
Debug
scratch

Bits	Perm	Init	Description
31:0	DRW		Value.

B.21 Instruction breakpoint address: 0x30 .. 0x33

This register contains the address of the instruction breakpoint. If the PC matches this address, then a debug interrupt will be taken. There are four instruction breakpoints that are controlled individually.

0x30 .. 0x33:
Instruction
breakpoint
address

Bits	Perm	Init	Description
31:0	DRW		Value.

B.22 Instruction breakpoint control: 0x40 .. 0x43

This register controls which logical cores may take an instruction breakpoint, and under which condition.

0x40 .. 0x43:
Instruction
breakpoint
control

Bits	Perm	Init	Description
31:24	RO	-	Reserved
23:16	DRW	0	A bit for each thread in the machine allowing the breakpoint to be enabled individually for each thread.
15:2	RO	-	Reserved
1	DRW	0	When 0 break when PC == IBREAK_ADDR. When 1 = break when PC != IBREAK_ADDR.
0	DRW	0	When 1 the instruction breakpoint is enabled.

B.23 Data watchpoint address 1: 0x50 .. 0x53

This set of registers contains the first address for the four data watchpoints.

0x50 .. 0x53:
Data
watchpoint
address 1

Bits	Perm	Init	Description
31:0	DRW		Value.

B.24 Data watchpoint address 2: 0x60 .. 0x63

This set of registers contains the second address for the four data watchpoints.

0x60 .. 0x63:
Data
watchpoint
address 2

Bits	Perm	Init	Description
31:0	DRW		Value.

B.25 Data breakpoint control register: 0x70 .. 0x73

This set of registers controls each of the four data watchpoints.

0x70 .. 0x73:
Data
breakpoint
control
register

Bits	Perm	Init	Description
31:24	RO	-	Reserved
23:16	DRW	0	A bit for each thread in the machine allowing the breakpoint to be enabled individually for each thread.
15:3	RO	-	Reserved
2	DRW	0	When 1 the breakpoints will be be triggered on loads.
1	DRW	0	Determines the break condition: 0 = A AND B, 1 = A OR B.
0	DRW	0	When 1 the instruction breakpoint is enabled.

B.26 Resources breakpoint mask: 0x80 .. 0x83

This set of registers contains the mask for the four resource watchpoints.

0x80 .. 0x83:
Resources
breakpoint
mask

Bits	Perm	Init	Description
31:0	DRW		Value.

B.27 Resources breakpoint value: 0x90 .. 0x93

This set of registers contains the value for the four resource watchpoints.

0x90 .. 0x93:
Resources
breakpoint
value

Bits	Perm	Init	Description
31:0	DRW		Value.

B.28 Resources breakpoint control register: 0x9C .. 0x9F

This set of registers controls each of the four resource watchpoints.

0x9C .. 0x9F:
Resources
breakpoint
control
register

Bits	Perm	Init	Description
31:24	RO	-	Reserved
23:16	DRW	0	A bit for each thread in the machine allowing the breakpoint to be enabled individually for each thread.
15:2	RO	-	Reserved
1	DRW	0	When 0 break when condition A is met. When 1 = break when condition B is met.
0	DRW	0	When 1 the instruction breakpoint is enabled.

C Tile Configuration

The xCORE Tile control registers can be accessed using configuration reads and writes (use `write_tile_config_reg(tileref, ...)` and `read_tile_config_reg(tileref, ...)` for reads and writes).

Number	Perm	Description
0x00	CRO	Device identification
0x01	CRO	xCORE Tile description 1
0x02	CRO	xCORE Tile description 2
0x04	CRW	Control PSwitch permissions to debug registers
0x05	CRW	Cause debug interrupts
0x06	CRW	xCORE Tile clock divider
0x07	CRO	Security configuration
0x20 .. 0x27	CRW	Debug scratch
0x40	CRO	PC of logical core 0
0x41	CRO	PC of logical core 1
0x42	CRO	PC of logical core 2
0x43	CRO	PC of logical core 3
0x44	CRO	PC of logical core 4
0x45	CRO	PC of logical core 5
0x46	CRO	PC of logical core 6
0x47	CRO	PC of logical core 7
0x60	CRO	SR of logical core 0
0x61	CRO	SR of logical core 1
0x62	CRO	SR of logical core 2
0x63	CRO	SR of logical core 3
0x64	CRO	SR of logical core 4
0x65	CRO	SR of logical core 5
0x66	CRO	SR of logical core 6
0x67	CRO	SR of logical core 7

Figure 34:
Summary

C.1 Device identification: 0x00

This register identifies the xCORE Tile

Bits	Perm	Init	Description
31:24	CRO		Processor ID of this XCore.
23:16	CRO		Number of the node in which this XCore is located.
15:8	CRO		XCore revision.
7:0	CRO		XCore version.

0x00:
Device
identification

C.2 xCORE Tile description 1: 0x01

This register describes the number of logical cores, synchronisers, locks and channel ends available on this xCORE tile.

Bits	Perm	Init	Description
31:24	CRO		Number of channel ends.
23:16	CRO		Number of the locks.
15:8	CRO		Number of synchronisers.
7:0	RO	-	Reserved

0x01:
xCORE Tile
description 1

C.3 xCORE Tile description 2: 0x02

This register describes the number of timers and clock blocks available on this xCORE tile.

Bits	Perm	Init	Description
31:16	RO	-	Reserved
15:8	CRO		Number of clock blocks.
7:0	CRO		Number of timers.

0x02:
xCORE Tile
description 2

C.4 Control PSwitch permissions to debug registers: 0x04

This register can be used to control whether the debug registers (marked with permission CRW) are accessible through the tile configuration registers. When this bit is set, write -access to those registers is disabled, preventing debugging of the xCORE tile over the interconnect.

Bits	Perm	Init	Description
31	CRW	0	When 1 the PSwitch is restricted to RO access to all CRW registers from SSwitch, XCore(PS_DBG_Scratch) and JTAG
30:1	RO	-	Reserved
0	CRW	0	When 1 the PSwitch is restricted to RO access to all CRW registers from SSwitch

0x04:
Control
PSwitch
permissions
to debug
registers

C.5 Cause debug interrupts: 0x05

This register can be used to raise a debug interrupt in this xCORE tile.

Bits	Perm	Init	Description
31:2	RO	-	Reserved
1	CRW	0	1 when the processor is in debug mode.
0	CRW	0	Request a debug interrupt on the processor.

0x05:
Cause debug
interrupts

C.6 xCORE Tile clock divider: 0x06

This register contains the value used to divide the PLL clock to create the xCORE tile clock. The divider is enabled under control of the [tile control register](#)

Bits	Perm	Init	Description
31	CRW	0	Clock disable. Writing '1' will remove the clock to the tile.
30:16	RO	-	Reserved
15:0	CRW	0	Clock divider.

0x06:
xCORE Tile
clock divider

C.7 Security configuration: 0x07

Copy of the security register as read from OTP.

0x07:
Security
configuration

Bits	Perm	Init	Description
31	CRO		Disables write permission on this register
30:15	RO	-	Reserved
14	CRO		Disable access to XCore's global debug
13	RO	-	Reserved
12	CRO		lock all OTP sectors
11:8	CRO		lock bit for each OTP sector
7	CRO		Enable OTP redundancy
6	RO	-	Reserved
5	CRO		Override boot mode and read boot image from OTP
4	CRO		Disable JTAG access to the PLL/BOOT configuration registers
3:1	RO	-	Reserved
0	CRO		Disable access to XCore's JTAG debug TAP

C.8 Debug scratch: 0x20 .. 0x27

A set of registers used by the debug ROM to communicate with an external debugger, for example over the switch. This is the same set of registers as the [Debug Scratch registers in the processor status](#).

0x20 .. 0x27:
Debug
scratch

Bits	Perm	Init	Description
31:0	CRW		Value.

C.9 PC of logical core 0: 0x40

Value of the PC of logical core 0.

0x40:
PC of logical
core 0

Bits	Perm	Init	Description
31:0	CRO		Value.

C.10 PC of logical core 1: 0x41

Value of the PC of logical core 1.

0x41:
PC of logical
core 1

Bits	Perm	Init	Description
31:0	CRO		Value.

C.11 PC of logical core 2: 0x42

Value of the PC of logical core 2.

0x42:
PC of logical
core 2

Bits	Perm	Init	Description
31:0	CRO		Value.

C.12 PC of logical core 3: 0x43

Value of the PC of logical core 3.

0x43:
PC of logical
core 3

Bits	Perm	Init	Description
31:0	CRO		Value.

C.13 PC of logical core 4: 0x44

Value of the PC of logical core 4.

0x44:
PC of logical
core 4

Bits	Perm	Init	Description
31:0	CRO		Value.

C.14 PC of logical core 5: 0x45

Value of the PC of logical core 5.

0x45:
PC of logical
core 5

Bits	Perm	Init	Description
31:0	CRO		Value.

C.15 PC of logical core 6: 0x46

Value of the PC of logical core 6.

0x46:
PC of logical
core 6

Bits	Perm	Init	Description
31:0	CRO		Value.

C.16 PC of logical core 7: 0x47

Value of the PC of logical core 7.

0x47:
PC of logical
core 7

Bits	Perm	Init	Description
31:0	CRO		Value.

C.17 SR of logical core 0: 0x60

Value of the SR of logical core 0

0x60:
SR of logical
core 0

Bits	Perm	Init	Description
31:0	CRO		Value.

C.18 SR of logical core 1: 0x61

Value of the SR of logical core 1

0x61:
SR of logical
core 1

Bits	Perm	Init	Description
31:0	CRO		Value.

C.19 SR of logical core 2: 0x62

Value of the SR of logical core 2

0x62:
SR of logical
core 2

Bits	Perm	Init	Description
31:0	CRO		Value.

C.20 SR of logical core 3: 0x63

Value of the SR of logical core 3

0x63:
SR of logical
core 3

Bits	Perm	Init	Description
31:0	CRO		Value.

C.21 SR of logical core 4: 0x64

Value of the SR of logical core 4

0x64:
SR of logical
core 4

Bits	Perm	Init	Description
31:0	CRO		Value.

C.22 SR of logical core 5: 0x65

Value of the SR of logical core 5

0x65:
SR of logical
core 5

Bits	Perm	Init	Description
31:0	CRO		Value.

C.23 SR of logical core 6: 0x66

Value of the SR of logical core 6

0x66:
SR of logical
core 6

Bits	Perm	Init	Description
31:0	CRO		Value.

C.24 SR of logical core 7: 0x67

Value of the SR of logical core 7

0x67:
SR of logical
core 7

Bits	Perm	Init	Description
31:0	CRO		Value.

D Node Configuration

The digital node control registers can be accessed using configuration reads and writes (use `write_node_config_reg(device, ...)` and `read_node_config_reg(device, ...)` for reads and writes).

Number	Perm	Description
0x00	RO	Device identification
0x01	RO	System switch description
0x04	RW	Switch configuration
0x05	RW	Switch node identifier
0x06	RW	PLL settings
0x07	RW	System switch clock divider
0x08	RW	Reference clock
0x09	R	System JTAG device ID register
0x0A	R	System USERCODE register
0x0C	RW	Directions 0-7
0x0D	RW	Directions 8-15
0x10	RW	DEBUG_N configuration, tile 0
0x11	RW	DEBUG_N configuration, tile 1
0x1F	RO	Debug source
0x20 .. 0x28	RW	Link status, direction, and network
0x40 .. 0x47	RO	PLink status and network
0x80 .. 0x88	RW	Link configuration and initialization
0xA0 .. 0xA7	RW	Static link configuration

Figure 35:
Summary

D.1 Device identification: 0x00

This register contains version and revision identifiers and the mode-pins as sampled at boot-time.

Bits	Perm	Init	Description
31:24	RO	-	Reserved
23:16	RO		Sampled values of BootCtl pins on Power On Reset.
15:8	RO		SSwitch revision.
7:0	RO		SSwitch version.

0x00:
Device
identification

D.2 System switch description: 0x01

This register specifies the number of processors and links that are connected to this switch.

0x01:
System
switch
description

Bits	Perm	Init	Description
31:24	RO	-	Reserved
23:16	RO		Number of SLinks on the SSwitch.
15:8	RO		Number of processors on the SSwitch.
7:0	RO		Number of processors on the device.

D.3 Switch configuration: 0x04

This register enables the setting of two security modes (that disable updates to the PLL or any other registers) and the header-mode.

0x04:
Switch
configuration

Bits	Perm	Init	Description
31	RW	0	0 = SSCTL registers have write access. 1 = SSCTL registers can not be written to.
30:9	RO	-	Reserved
8	RW	0	0 = PLL_CTL_REG has write access. 1 = PLL_CTL_REG can not be written to.
7:1	RO	-	Reserved
0	RW	0	0 = 2-byte headers, 1 = 1-byte headers (reset as 0).

D.4 Switch node identifier: 0x05

This register contains the node identifier.

0x05:
Switch node
identifier

Bits	Perm	Init	Description
31:16	RO	-	Reserved
15:0	RW	0	The unique ID of this node.

D.5 PLL settings: 0x06

An on-chip PLL multiplies the input clock up to a higher frequency clock, used to clock the I/O, processor, and switch, see [Oscillator](#). Note: a write to this register will cause the tile to be reset.

Bits	Perm	Init	Description
31	RW		If set to 1, the chip will not be reset
30	RW		If set to 1, the chip will not wait for the PLL to re-lock. Only use this if a gradual change is made to the PLL
29	DW		If set to 1, set the PLL to be bypassed
28	DW		If set to 1, set the boot mode to boot from JTAG
27:26	RO	-	Reserved
25:23	RW		Output divider value range from 1 (8'h0) to 250 (8'hF9). P value.
22:21	RO	-	Reserved
20:8	RW		Feedback multiplication ratio, range from 1 (8'h0) to 255 (8'hFE). M value.
7	RO	-	Reserved
6:0	RW		Oscillator input divider value range from 1 (8'h0) to 32 (8'h0F). N value.

0x06:
PLL settings

D.6 System switch clock divider: 0x07

Sets the ratio of the PLL clock and the switch clock.

Bits	Perm	Init	Description
31:16	RO	-	Reserved
15:0	RW	0	SSwitch clock generation

0x07:
System
switch clock
divider

D.7 Reference clock: 0x08

Sets the ratio of the PLL clock and the reference clock used by the node.

Bits	Perm	Init	Description
31:16	RO	-	Reserved
15:0	RW	3	Software ref. clock divider

0x08:
Reference
clock

D.8 System JTAG device ID register: 0x09

0x09:
System JTAG
device ID
register

Bits	Perm	Init	Description
31:28	RO		
27:12	RO		
11:1	RO		
0	RO		

D.9 System USERCODE register: 0x0A

0x0A:
System
USERCODE
register

Bits	Perm	Init	Description
31:18	RO		JTAG USERCODE value programmed into OTP SR
17:0	RO		metal fixable ID code

D.10 Directions 0-7: 0x0C

This register contains eight directions, for packets with a mismatch in bits 7..0 of the node-identifier. The direction in which a packet will be routed is governed by the most significant mismatching bit.

0x0C:
Directions
0-7

Bits	Perm	Init	Description
31:28	RW	0	The direction for packets whose dimension is 7.
27:24	RW	0	The direction for packets whose dimension is 6.
23:20	RW	0	The direction for packets whose dimension is 5.
19:16	RW	0	The direction for packets whose dimension is 4.
15:12	RW	0	The direction for packets whose dimension is 3.
11:8	RW	0	The direction for packets whose dimension is 2.
7:4	RW	0	The direction for packets whose dimension is 1.
3:0	RW	0	The direction for packets whose dimension is 0.

D.11 Directions 8-15: 0x0D

This register contains eight directions, for packets with a mismatch in bits 15..8 of the node-identifier. The direction in which a packet will be routed is governed by the most significant mismatching bit.

0x0D:
Directions
8-15

Bits	Perm	Init	Description
31:28	RW	0	The direction for packets whose dimension is F.
27:24	RW	0	The direction for packets whose dimension is E.
23:20	RW	0	The direction for packets whose dimension is D.
19:16	RW	0	The direction for packets whose dimension is C.
15:12	RW	0	The direction for packets whose dimension is B.
11:8	RW	0	The direction for packets whose dimension is A.
7:4	RW	0	The direction for packets whose dimension is 9.
3:0	RW	0	The direction for packets whose dimension is 8.

D.12 DEBUG_N configuration, tile 0: 0x10

Configures the behavior of the DEBUG_N pin.

0x10:
DEBUG_N con-
figuration,
tile 0

Bits	Perm	Init	Description
31:2	RO	-	Reserved
1	RW	0	Set 1 to enable GlobalDebug to generate debug request to XCore.
0	RW	0	Set 1 to enable inDebug bit to drive GlobalDebug.

D.13 DEBUG_N configuration, tile 1: 0x11

Configures the behavior of the DEBUG_N pin.

0x11:
DEBUG_N con-
figuration,
tile 1

Bits	Perm	Init	Description
31:2	RO	-	Reserved
1	RW	0	Set 1 to enable GlobalDebug to generate debug request to XCore.
0	RW	0	Set 1 to enable inDebug bit to drive GlobalDebug.

D.14 Debug source: 0x1F

Contains the source of the most recent debug event.

0x1F:
Debug source

Bits	Perm	Init	Description
31:5	RO	-	Reserved
4	RW		If set, external pin, is the source of last GlobalDebug event.
3:2	RO	-	Reserved
1	RW		If set, XCore1 is the source of last GlobalDebug event.
0	RW		If set, XCore0 is the source of last GlobalDebug event.

D.15 Link status, direction, and network: 0x20 .. 0x28

These registers contain status information for low level debugging (read-only), the network number that each link belongs to, and the direction that each link is part of. The registers control links 0..7.

0x20 .. 0x28:
Link status,
direction, and
network

Bits	Perm	Init	Description
31:26	RO	-	Reserved
25:24	RO		Identify the SRC_TARGET type 0 - SLink, 1 - PLink, 2 - SSCTL, 3 - Undefine.
23:16	RO		When the link is in use, this is the destination link number to which all packets are sent.
15:12	RO	-	Reserved
11:8	RW	0	The direction that this link operates in.
7:6	RO	-	Reserved
5:4	RW	0	Determines the network to which this link belongs, reset as 0.
3	RO	-	Reserved
2	RO		1 when the current packet is considered junk and will be thrown away.
1	RO		1 when the dest side of the link is in use.
0	RO		1 when the source side of the link is in use.

D.16 PLink status and network: 0x40 .. 0x47

These registers contain status information and the network number that each processor-link belongs to.

0x40 .. 0x47:
PLink status
and network

Bits	Perm	Init	Description
31:26	RO	-	Reserved
25:24	RO		Identify the SRC_TARGET type 0 - SLink, 1 - PLink, 2 - SSCTL, 3 - Undefine.
23:16	RO		When the link is in use, this is the destination link number to which all packets are sent.
15:6	RO	-	Reserved
5:4	RW	0	Determines the network to which this link belongs, reset as 0.
3	RO	-	Reserved
2	RO		1 when the current packet is considered junk and will be thrown away.
1	RO		1 when the dest side of the link is in use.
0	RO		1 when the source side of the link is in use.

D.17 Link configuration and initialization: 0x80 .. 0x88

These registers contain configuration and debugging information specific to external links. The link speed and width can be set, the link can be initialized, and the link status can be monitored. The registers control links 0..7.

0x80 .. 0x88:
Link
configuration
and
initialization

Bits	Perm	Init	Description
31	RW		Write to this bit with '1' will enable the XLink, writing '0' will disable it. This bit controls the muxing of ports with overlapping xlinks.
30	RW	0	0: operate in 2 wire mode; 1: operate in 5 wire mode
29:28	RO	-	Reserved
27	RO		Rx buffer overflow or illegal token encoding received.
26	RO	0	This end of the xlink has issued credit to allow the remote end to transmit
25	RO	0	This end of the xlink has credit to allow it to transmit.
24	WO		Clear this end of the xlink's credit and issue a HELLO token.
23	WO		Reset the receiver. The next symbol that is detected will be the first symbol in a token.
22	RO	-	Reserved
21:11	RW	0	Specify min. number of idle system clocks between two continuous symbols within a transmit token -1.
10:0	RW	0	Specify min. number of idle system clocks between two continuous transmit tokens -1.

D.18 Static link configuration: 0xA0 .. 0xA7

These registers are used for static (ie, non-routed) links. When a link is made static, all traffic is forwarded to the designated channel end and no routing is attempted. The registers control links C, D, A, B, G, H, E, and F in that order.

0xA0 .. 0xA7:
Static link
configuration

Bits	Perm	Init	Description
31	RW	0	Enable static forwarding.
30:9	RO	-	Reserved
8	RW	0	The destination processor on this node that packets received in static mode are forwarded to.
7:5	RO	-	Reserved
4:0	RW	0	The destination channel end on this node that packets received in static mode are forwarded to.

E USB Node Configuration

The USB node control registers can be accessed using configuration reads and writes (use `write_node_config_reg(device, ...)` and `read_node_config_reg(device, ...)` for reads and writes).

Number	Perm	Description
0x00	RO	Device identification register
0x04	RW	Node configuration register
0x05	RW	Node identifier
0x51	RW	System clock frequency
0x80	RW	Link Control and Status

Figure 36:
Summary

E.1 Device identification register: 0x00

This register contains version information, and information on power-on behavior.

Bits	Perm	Init	Description
31:24	RO	0x0F	Chip identifier
23:16	RO	-	Reserved
15:8	RO	0x02	Revision number of the USB block
7:0	RO	0x00	Version number of the USB block

0x00:
Device
identification
register

E.2 Node configuration register: 0x04

This register is used to set the communication model to use (1 or 3 byte headers), and to prevent any further updates.

Bits	Perm	Init	Description
31	RW	0	Set to 1 to disable further updates to the node configuration and link control and status registers.
30:1	RO	-	Reserved
0	RW	0	Header mode. 0: 3-byte headers; 1: 1-byte headers.

0x04:
Node
configuration
register

E.3 Node identifier: 0x05

0x05:
Node
identifier

Bits	Perm	Init	Description
31:16	RO	-	Reserved
15:0	RW	0	16-bit node identifier. This does not need to be set, and is present for compatibility with XS1-switches.

E.4 System clock frequency: 0x51

0x51:
System clock
frequency

Bits	Perm	Init	Description
31:7	RO	-	Reserved
6:0	RW	25	Oscillator clock frequency in MHz rounded up to the nearest integer value. Only values between 5 and 100 MHz are valid - writes outside this range are ignored and will be NACKed. This field must be set on start up of the device and any time that the input oscillator clock frequency is changed. It must contain the system clock frequency in MHz rounded up to the nearest integer value.

E.5 Link Control and Status: 0x80

0x80:
Link Control
and Status

Bits	Perm	Init	Description
31:28	RO	-	Reserved
27	RO		Rx buffer overflow or illegal token encoding received.
26	RO	0	This end of the xlink has issued credit to allow the remote end to transmit
25	RO	0	This end of the xlink has credit to allow it to transmit.
24	WO		Clear this end of the xlink's credit and issue a HELLO token.
23	WO		Reset the receiver. The next symbol that is detected will be the first symbol in a token.
22	RO	-	Reserved
21:11	RW	1	Specify min. number of idle system clocks between two continuous symbols within a transmit token -1.
10:0	RW	1	Specify min. number of idle system clocks between two continuous transmit tokens -1.

F USB PHY Configuration

The USB PHY is connected to the ports shown in section 10.

The *USB PHY* is peripheral 1. The control registers are accessed using 32-bit reads and writes (use `write_periph_32(device, 1, ...)` and `read_periph_32(device, ↪ 1, ...)` for reads and writes).

Number	Perm	Description
0x00	WO	UIFM reset
0x04	RW	UIFM IFM control
0x08	RW	UIFM Device Address
0x0C	RW	UIFM functional control
0x10	RW	UIFM on-the-go control
0x14	RO	UIFM on-the-go flags
0x18	RW	UIFM Serial Control
0x1C	RW	UIFM signal flags
0x20	RW	UIFM Sticky flags
0x24	RW	UIFM port masks
0x28	RW	UIFM SOF value
0x2C	RO	UIFM PID
0x30	RO	UIFM Endpoint
0x34	RW	UIFM Endpoint match
0x38	RW	OTG Flags mask
0x3C	RW	UIFM power signalling
0x40	RW	UIFM PHY control

Figure 37:
Summary

F.1 UIFM reset: 0x00

A write to this register with any data resets all UIFM state, but does not otherwise affect the phy.

0x00:
UIFM reset

Bits	Perm	Init	Description
31:0	WO		Value.

F.2 UIFM IFM control: 0x04

General settings of the UIFM IFM state machine.

0x04:
UIFM IFM
control

Bits	Perm	Init	Description
31:8	RO	-	Reserved
7	RW	0	Set to 1 to enable XEVACKMODE mode.
6	RW	0	Set to 1 to enable SOFISTOKEN mode.
5	RW	0	Set to 1 to enable UIFM power signalling mode.
4	RW	0	Set to 1 to enable IF timing mode.
3	RO	-	Reserved
2	RW	0	Set to 1 to enable UIFM linestate decoder.
1	RW	0	Set to 1 to enable UIFM CHECKTOKENS mode.
0	RW	0	Set to 1 to enable UIFM DOTOKENS mode.

F.3 UIFM Device Address: 0x08

The device address whose packets should be received. 0 until enumeration, it should be set to the assigned value after enumeration.

0x08:
UIFM Device
Address

Bits	Perm	Init	Description
31:7	RO	-	Reserved
6:0	RW	0	The enumerated USB device address must be stored here. Only packets to this address are passed on.

F.4 UIFM functional control: 0x0C

0x0C:
UIFM
functional
control

Bits	Perm	Init	Description
31:5	RO	-	Reserved
4:2	RW	1	Set to 0 to disable UIFM to UTMI+ OPMODE mode.
1	RW	1	Set to 1 to switch UIFM to UTMI+ TERMSELECT mode.
0	RW	1	Set to 1 to switch UIFM to UTMI+ XCVRSELECT mode.

F.5 UIFM on-the-go control: 0x10

This register is used to negotiate an on-the-go connection.

0x10:
UIFM
on-the-go
control

Bits	Perm	Init	Description
31:8	RO	-	Reserved
7	RW	0	Set to 1 to switch UIFM to EXTVBUSIND mode.
6	RW	0	Set to 1 to switch UIFM to DRVVBUSEXT mode.
5	RO	-	Reserved
4	RW	0	Set to 1 to switch UIFM to UTMI+ CHRGVBUS mode.
3	RW	0	Set to 1 to switch UIFM to UTMI+ DISCHRGVBUS mode.
2	RW	0	Set to 1 to switch UIFM to UTMI+ DMPULLDOWN mode.
1	RW	0	Set to 1 to switch UIFM to UTMI+ DPPULLDOWN mode.
0	RW	0	Set to 1 to switch UIFM to IDPULLUP mode.

F.6 UIFM on-the-go flags: 0x14

Status flags used for on-the-go negotiation

0x14:
UIFM
on-the-go
flags

Bits	Perm	Init	Description
31:6	RO	-	Reserved
5	RO	0	Value of UTMI+ Bvalid flag.
4	RO	0	Value of UTMI+ IDGND flag.
3	RO	0	Value of UTMI+ HOSTDIS flag.
2	RO	0	Value of UTMI+ VBUSVLD flag.
1	RO	0	Value of UTMI+ SESSVLD flag.
0	RO	0	Value of UTMI+ SESEND flag.

F.7 UIFM Serial Control: 0x18

0x18:
UIFM Serial
Control

Bits	Perm	Init	Description
31:7	RO	-	Reserved
6	RO	0	1 if UIFM is in UTMI+ RXRCV mode.
5	RO	0	1 if UIFM is in UTMI+ RXDM mode.
4	RO	0	1 if UIFM is in UTMI+ RXDP mode.
3	RW	0	Set to 1 to switch UIFM to UTMI+ TXSE0 mode.
2	RW	0	Set to 1 to switch UIFM to UTMI+ TXDATA mode.
1	RW	1	Set to 0 to switch UIFM to UTMI+ TXENABLE mode.
0	RW	0	Set to 1 to switch UIFM to UTMI+ FLSLSSERIAL mode.

F.8 UIFM signal flags: 0x1C

Set of flags that monitor line and error states. These flags normally clear on the next packet, but they may be made sticky by using PER_UIFM_FLAGS_STICKY, in which they must be cleared explicitly.

0x1C:
UIFM signal
flags

Bits	Perm	Init	Description
31:7	RO	-	Reserved
6	RW	0	Set to 1 when the UIFM decodes a token successfully (e.g. it passes CRC5, PID check and has matching device address).
5	RW	0	Set to 1 when linestate indicates an SE0 symbol.
4	RW	0	Set to 1 when linestate indicates a K symbol.
3	RW	0	Set to 1 when linestate indicates a J symbol.
2	RW	0	Set to 1 if an incoming datapacket fails the CRC16 check.
1	RW	0	Set to the value of the UTMI_RXACTIVE input signal.
0	RW	0	Set to the value of the UTMI_RXERROR input signal

F.9 UIFM Sticky flags: 0x20

These bits define the sticky-ness of the bits in the UIFM IFM FLAGS register. A 1 means that bit will be sticky (hold its value until a 1 is written to that bitfield), or normal, in which case signal updates to the UIFM IFM FLAGS bits may be over-written by subsequent changes in those signals.

0x20: UIFM Sticky flags	Bits	Perm	Init	Description
	31:7	RO	-	Reserved
	6:0	RW	0	Stickyness for each flag.

F.10 UIFM port masks: 0x24

Set of masks that identify how port 1N, port 1O and port 1P are affected by changes to the flags in FLAGS

0x24: UIFM port masks	Bits	Perm	Init	Description
	31:24	RW	0	Bit mask that determines which flags in UIFM_IFM_FLAG[6:0] contribute to port 1?. If any flag listed in this bitmask is high, port 1? will be high.
	23:16	RW	0	Bit mask that determines which flags in UIFM_IFM_FLAG[6:0] contribute to port 1P. If any flag listed in this bitmask is high, port 1P will be high.
	15:8	RW	0	Bit mask that determines which flags in UIFM_IFM_FLAG[6:0] contribute to port 1O. If any flag listed in this bitmask is high, port 1O will be high.
	7:0	RW	0	Bit mask that determines which flags in UIFM_IFM_FLAG[6:0] contribute to port 1N. If any flag listed in this bitmask is high, port 1N will be high.

F.11 UIFM SOF value: 0x28

USB Start-Of-Frame counter

0x28: UIFM SOF value	Bits	Perm	Init	Description
	31:11	RO	-	Reserved
	10:8	RW	0	Most significant 3 bits of SOF counter
7:0	RW	0	Least significant 8 bits of SOF counter	

F.12 UIFM PID: 0x2C

The last USB packet identifier received

	Bits	Perm	Init	Description
0x2C: UIFM PID	31:4	RO	-	Reserved
	3:0	RO	0	Value of the last received PID.

F.13 UIFM Endpoint: 0x30

The last endpoint seen

	Bits	Perm	Init	Description
0x30: UIFM Endpoint	31:5	RO	-	Reserved
	4	RO	0	1 if endpoint contains a valid value.
	3:0	RO	0	A copy of the last received endpoint.

F.14 UIFM Endpoint match: 0x34

This register can be used to mark UIFM endpoints as special.

	Bits	Perm	Init	Description
0x34: UIFM Endpoint match	31:16	RO	-	Reserved
	15:0	RW	0	This register contains a bit for each endpoint. If its bit is set, the endpoint will be supplied on the RX port when ORed with 0x10.

F.15 OTG Flags mask: 0x38

	Bits	Perm	Init	Description
0x38: OTG Flags mask	31:0	RW	0	Data

F.16 UIFM power signalling: 0x3C

	Bits	Perm	Init	Description
0x3C: UIFM power signalling	31:9	RO	-	Reserved
	8	RW	0	Valid
	7:0	RW	0	Data

F.17 UIFM PHY control: 0x40

Bits	Perm	Init	Description
31:19	RO	-	Reserved
18	RW	0	Set to 1 to disable pulldowns on ports 8A and 8B.
17:14	RO	-	Reserved
13	RW	0	After an auto-resume, this bit is set to indicate that the resume signalling was for reset (se0). Set to 0 to clear.
12	RW	0	After an auto-resume, this bit is set to indicate that the resume signalling was for resume (K). Set to 0 to clear.
11:8	RW	0	Log-2 number of clocks before any linstestate change is propagated.
7	RW	0	Set to 1 to use the suspend controller handle to resume from suspend. Otherwise, the program has to poll the linstestate_filt field in phy_teststatus.
6:4	RW	0	Control the the conf1,2,3 input pins of the PHY.
3:0	RO	-	Reserved

0x40:
UIFM PHY
control

G JTAG, xSCOPE and Debugging

If you intend to design a board that can be used with the XMOS toolchain and xTAG debugger, you will need an xSYS header on your board. Figure 38 shows a decision diagram which explains what type of xSYS connectivity you need. The three subsections below explain the options in detail.

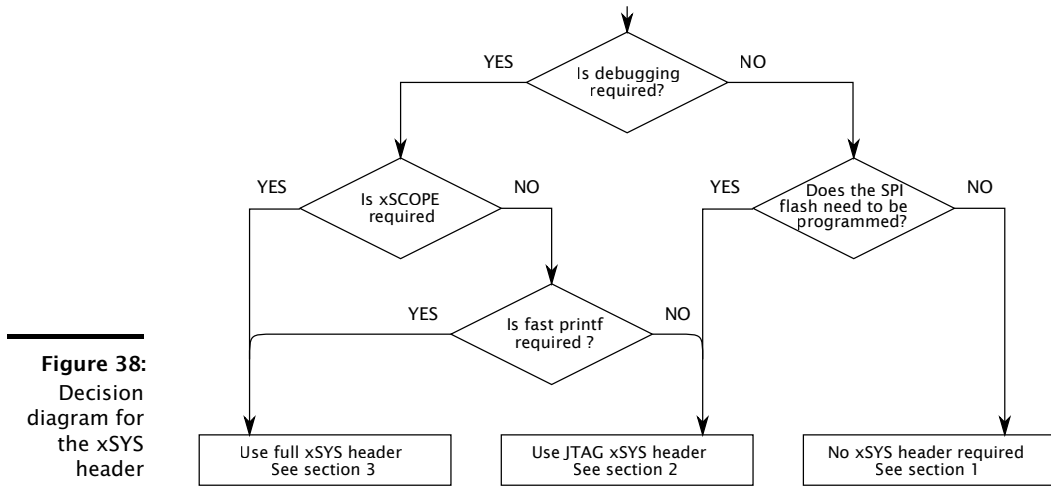

G.1 No xSYS header

The use of an xSYS header is optional, and may not be required for volume production designs. However, the XMOS toolchain expects the xSYS header; if you do not have an xSYS header then you must provide your own method for writing to flash/OTP and for debugging.

G.2 JTAG-only xSYS header

The xSYS header connects to an xTAG debugger, which has a 20-pin 0.1" female IDC header. The design will hence need a male IDC header. We advise to use a boxed header to guard against incorrect plug-ins. If you use a 90 degree angled header, make sure that pins 2, 4, 6, ..., 20 are along the edge of the PCB.

Connect pins 4, 8, 12, 16, 20 of the xSYS header to ground, and then connect:

- ▶ TDI to pin 5 of the xSYS header
- ▶ TMS to pin 7 of the xSYS header
- ▶ TCK to pin 9 of the xSYS header
- ▶ DEBUG_N to pin 11 of the xSYS header

- ▶ TDO to pin 13 of the xSYS header

The RST_N net should be open-drain, active-low, and have a pull-up to VDDIO.

G.3 Full xSYS header

For a full xSYS header you will need to connect the pins as discussed in Section G.2, and then connect a 2-wire xCONNECT Link to the xSYS header. The links can be found in the Signal description table (Section 4): they are labelled XL0, XL1, etc in the function column. The 2-wire link comprises two inputs and outputs, labelled ${}^1_{out}$, ${}^0_{out}$, ${}^0_{in}$, and ${}^1_{in}$. For example, if you choose to use XL0 for xSCOPE I/O, you need to connect up $XL0^1_{out}$, $XL0^0_{out}$, $XL0^0_{in}$, $XL0^1_{in}$ as follows:

- ▶ $XL0^1_{out}$ (X0D43) to pin 6 of the xSYS header with a 33R series resistor close to the device.
- ▶ $XL0^0_{out}$ (X0D42) to pin 10 of the xSYS header with a 33R series resistor close to the device.
- ▶ $XL0^0_{in}$ (X0D41) to pin 14 of the xSYS header.
- ▶ $XL0^1_{in}$ (X0D40) to pin 18 of the xSYS header.

H Schematics Design Check List

- This section is a checklist for use by schematics designers using the XU224-1024-FB374. Each of the following sections contains items to check for each design.

H.1 Power supplies

- VDDIO and OTP_VCC supply is within specification before the VDD (core) supply is turned on. Specifically, the VDDIO and OTP_VCC supply is within specification before VDD (core) reaches 0.4V (Section 12).
- The VDD (core) supply ramps monotonically (rises constantly) from 0V to its final value (0.95V - 1.05V) within 10ms (Section 12).
- The VDD (core) supply is capable of supplying 1400 mA (Section 12 and Figure 21).
- PLL_AVDD is filtered with a low pass filter, for example an RC filter, see Section 12

H.2 Power supply decoupling

- The design has multiple decoupling capacitors per supply, for example at least four 0402 or 0603 size surface mount capacitors of 100nF in value, per supply (Section 12).
- A bulk decoupling capacitor of at least 10uF is placed on each supply (Section 12).

H.3 Power on reset

- The RST_N and TRST_N pins are asserted (low) during or after power up. The device is not used until these resets have taken place.

H.4 Clock

- The CLK input pin is supplied with a clock with monotonic rising edges and low jitter.
- Pins MODE0 and MODE1 are set to the correct value for the chosen oscillator frequency. The MODE settings are shown in the Oscillator section, Section 7. If you have a choice between two values, choose the value with the highest multiplier ratio since that will boot faster.

H.5 Boot

- The device is connected to a QSPI flash for booting, connected to X0D01, X0D04..X0D07, and X0D10 (Section 8). If not, you must boot the device through OTP or JTAG, or set it to boot from SPI and connect a SPI flash.
- The Flash that you have chosen is supported by **xflash**, or you have created a specification file for it.

H.6 JTAG, XScope, and debugging

- You have decided as to whether you need an XSYS header or not (Section G)
- If you have not included an XSYS header, you have devised a method to program the SPI-flash or OTP (Section G).

H.7 GPIO

- You have not mapped both inputs and outputs to the same multi-bit port.
- Pins X0D04, X0D05, X0D06, and X0D07 are output only and are, during and after reset, pulled high and low appropriately (Section 8)
- Pins X2D04, X2D05, X2D06 and X2D07 are output only and during and after reset, X2D06 is pulled high and X2D04, X2D05, and X2D07 are pulled low (Section 8)

H.8 Multi device designs

Skip this section if your design only includes a single XMOS device.

- One device is connected to a QSPI or SPI flash for booting.
- Devices that boot from link have, for example, X0D06 pulled high and have link XL0 connected to a device to boot from (Section 8).

I PCB Layout Design Check List

- This section is a checklist for use by PCB designers using the XS2-U24A-1024-FB374. Each of the following sections contains items to check for each design.

I.1 Ground Plane

- Each ground ball has a via to minimize impedance and conduct heat away from the device. (Section [12.4](#))
- Other than ground vias, there are no (or only a few) vias underneath or closely around the device. This create a good, solid, ground plane.

I.2 Power supply decoupling

- The decoupling capacitors are all placed close to a supply pin (Section [12](#)).
- The decoupling capacitors are spaced around the device (Section [12](#)).
- The ground side of each decoupling capacitor has a direct path back to the center ground of the device.

I.3 PLL_AVDD

- The PLL_AVDD filter (especially the capacitor) is placed close to the PLL_AVDD pin (Section [12](#)).

J Associated Design Documentation

Document Title	Information	Document Number
Estimating Power Consumption For XS1-U Devices	Power consumption	
Programming XC on XMOS Devices	Timers, ports, clocks, cores and channels	X9577
xTIMEcomposer User Guide	Compilers, assembler and linker/mapper Timing analyzer, xScope, debugger Flash and OTP programming utilities	X3766

K Related Documentation

Document Title	Information	Document Number
The XMOS XS1 Architecture	ISA manual	X7879
XS1 Port I/O Timing	Port timings	X5821
xCONNECT Architecture	Link, switch and system information	X4249
XS1-U Link Performance and Design Guidelines	Link timings	
XS1-U Clock Frequency Control	Advanced clock control	

L Revision History

Date	Description
2015-03-20	Preliminary release
2015-04-14	Added RST to pins to be pulled hard, and removed reference to TCK from Errata Removed TRST_N references in packages that have no TRST_N
2015-05-06	Removed references to DEBUG_N
2015-07-09	Updated electrical characteristics - Section 13
2015-08-19	Added I(USB_VDD) - Section 13 Added USB layout guidelines - Section 12
2015-08-27	Updated part marking and product code - Section 15
2015-11-23	Updated status of X2D04, X2D05, X2D06, X2D07 during boot - Section 8 Updated Schematics Design Checklist: GPIO for X2D04, X2D05, X2D06, X2D07 during boot - Section H
2015-12-18	Clarified connectivity of internal and external xCONNECT links - Sections 3 and 4 Made pin names canonical - Sections 3 and 4 Updated JTAG diagram - Section 11 Removed references to 400MHz parts - Section 13
2016-01-05	Updated signal tables to use VDDIO - Section 4 Updated IDD value - Section 13 Updated land pattern description - Section 12.3
2016-04-20	Typical internal pull-up and pull down current diagrams added - Section 13



Copyright © 2016, All Rights Reserved.

Xmos Ltd. is the owner or licensee of this design, code, or Information (collectively, the "Information") and is providing it to you "AS IS" with no warranty of any kind, express or implied and shall have no liability in relation to its use. Xmos Ltd. makes no representation that the Information, or any particular implementation thereof, is or will be free from any claims of infringement and again, shall have no liability in relation to any such claims.