

OPA-X-X-X-XX

PORTS
SINGLE: -S
DOUBLE: -D

FOOTPRINT
BLANK STANDARD

KEY
OPPOSED: -1
ALIGNED: -2

FLANGE
-F: FULL

DO NOT
SCALE FROM
THIS PRINT

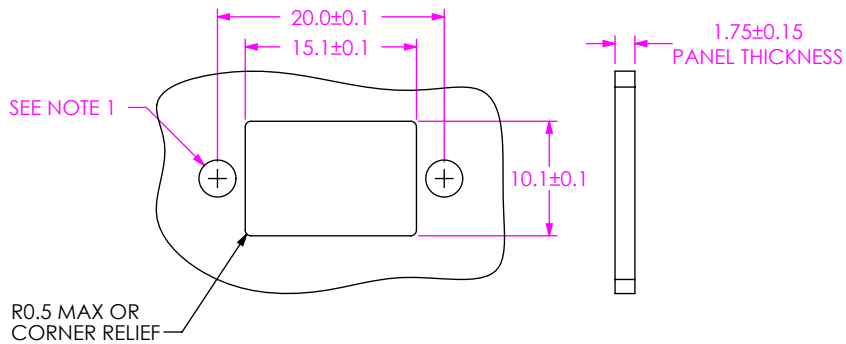
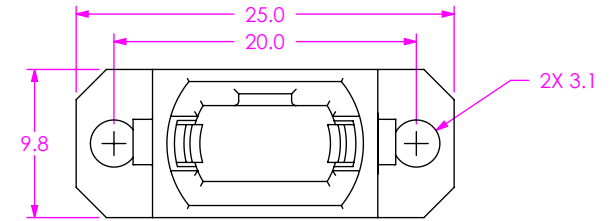
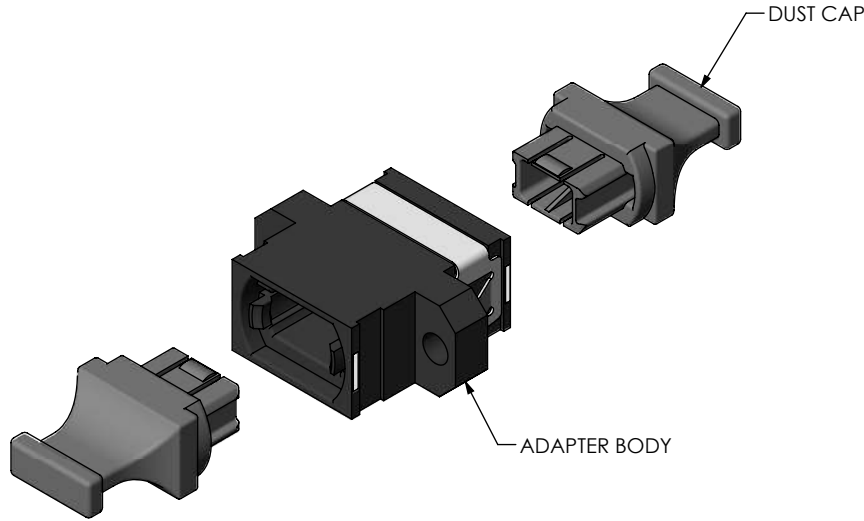

RECOMMENDED MOUNTING CUTOUT
OPA-S-X-F

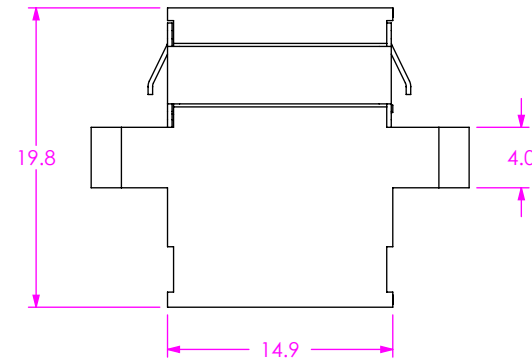

NOTES:
1. RECOMMEND USE OF M2.5 OR 4-40 SCREW, OR SCREW WITH NUT,
SCREW HEAD DIAMETER & NUT WIDTH ≤ 5mm
(SCREW & NUT NOT PROVIDED).
RECOMMEND 2in-lbf TORQUE FOR SCREW
MOUNT APPLICATIONS

F:\DWG\MISC\MKTG\OPA-X-X-X-XX-MKT.SLDDRW

UNLESS OTHERWISE SPECIFIED,
DIMENSIONS ARE IN MILLIMETERS.
TOLERANCES ARE:
DECIMALS ANGLES
X.X: ±0.3 2°
X.XX: ±0.05
X.XXX: ±0.025

PROPRIETARY NOTE

THIS DOCUMENT CONTAINS INFORMATION
CONFIDENTIAL AND PROPRIETARY TO
SAMTEC, INC. AND SHALL NOT BE REPRODUCED
OR TRANSFERRED TO OTHER DOCUMENTS OR
DISCLOSED TO OTHERS OR USED FOR ANY
PURPOSE OTHER THAN THAT WHICH IT WAS
OBTAINED WITHOUT THE EXPRESSED WRITTEN
CONSENT OF SAMTEC, INC.



520 PARK EAST BLVD., NEW ALBANY, IN 47150
PHONE: 812-944-6733 FAX: 812-948-5047
e-Mail: info@SAMTEC.com code 55322

MATERIAL: DO NOT SCALE DRAWING SHEET SCALE: 2:1

DESCRIPTION:
OPTICAL PANEL ADAPTER

DWG. NO.
OPA-X-X-X-XX

BY: JEAN W. 02/05/2015 SHEET 1 OF 3

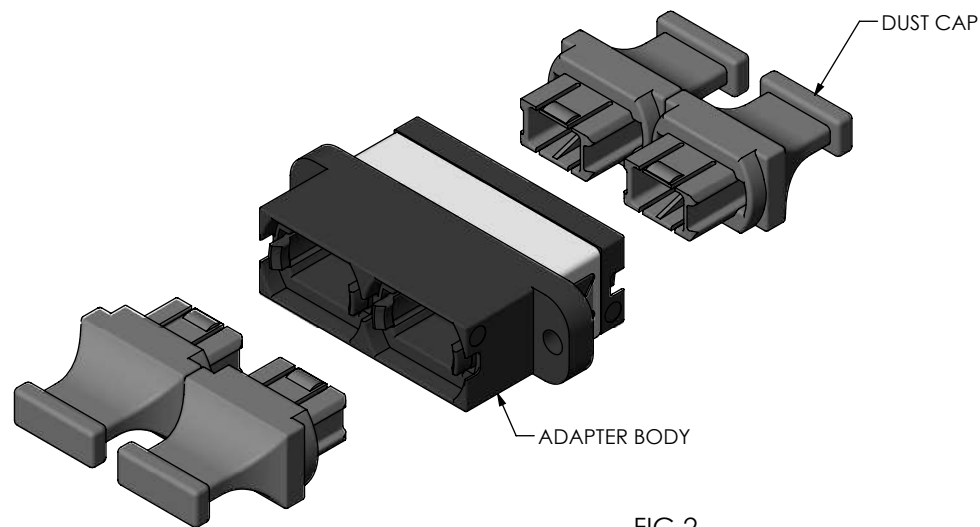
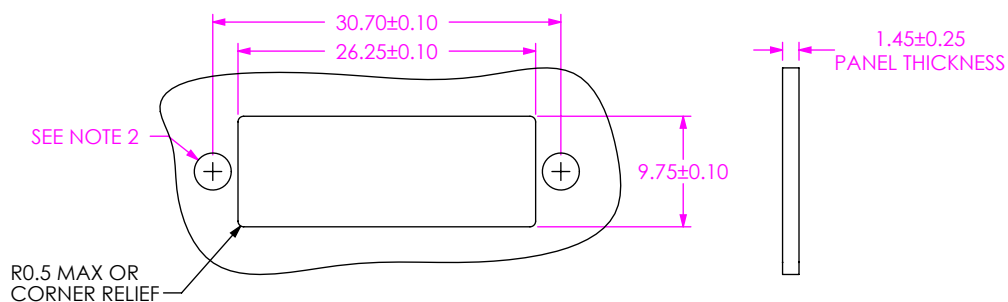
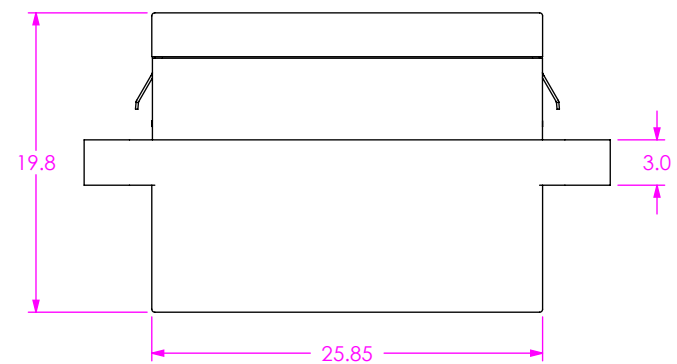
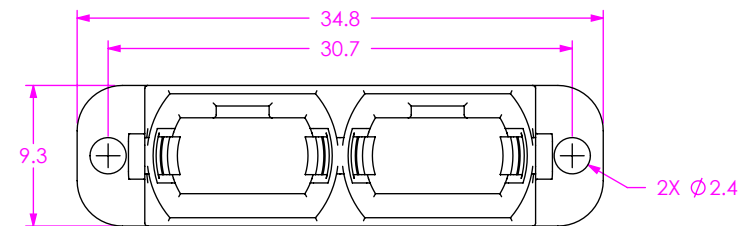

FIG 2
OPA-D-1-F



RECOMMENDED MOUNTING CUTOUT
OPA-D-X-F

- NOTES:
 1. ALSO COMPLIANT WITH FOCIS STANDARD TOLERANCE OF $\pm 0.25\text{mm}$
 2. RECOMMEND USE OF M2 OR 2-56 SCREW, OR SCREW WITH NUT, (SCREW & NUT NOT PROVIDED).
 RECOMMEND 2in-lbf TORQUE FOR SCREW MOUNT APPLICATIONS.

PROPRIETARY NOTE

THIS DOCUMENT CONTAINS INFORMATION CONFIDENTIAL AND PROPRIETARY TO SAMTEC, INC. AND SHALL NOT BE REPRODUCED OR TRANSFERRED TO OTHER DOCUMENTS OR DISCLOSED TO OTHERS OR USED FOR ANY PURPOSE OTHER THAN THAT WHICH IT WAS OBTAINED WITHOUT THE EXPRESSED WRITTEN CONSENT OF SAMTEC, INC.



520 PARK EAST BLVD, NEW ALBANY, IN 47150
 PHONE: 812-944-6733 FAX: 812-948-5047
 e-Mail info@SAMTEC.com code 55322

SHEET SCALE: 2:1

DESCRIPTION: OPTICAL PANEL ADAPTER

DWG. NO. OPA-X-X-X-XX

BY: JEAN W. 02/05/2015 SHEET 2 OF 3

| MATERIALS TABLE | | | |
|-----------------|----------------|-----------------|---------------|
| PART NUMBER | ADAPTER BODY | SPRING CLIP | DUST CAP |
| OPA-S-1-F | POLYETHERIMIDE | STAINLESS STEEL | POLYCARBONATE |
| OPA-S-2-F | POLYETHERIMIDE | STAINLESS STEEL | POLYCARBONATE |
| OPA-D-1-F | POLYETHERIMIDE | STAINLESS STEEL | POLYCARBONATE |
| OPA-D-2-F | POLYETHERIMIDE | STAINLESS STEEL | POLYCARBONATE |

| COLOR TABLE | | |
|-------------|--------------|----------|
| PART NUMBER | ADAPTER BODY | DUST CAP |
| OPA-S-1-F | BLACK | CHARCOAL |
| OPA-S-2-F | GRAY | CHARCOAL |
| OPA-D-1-F | BLACK | CHARCOAL |
| OPA-D-2-F | GRAY | CHARCOAL |

| BOM TABLE | | | | |
|-------------|------------------|------------------|------|----------|
| PART NUMBER | BOM ITEM | DESCRIPTION | QTY | COST QTY |
| OPA-S-1-F | CCS-185473-01-CN | BULKHEAD ADAPTER | 1 | 1 |
| | BAG-SS-06X08-Z | PACKAGING BAG | 0.02 | 0.02 |
| | LABEL-4X2 | LABEL | 0 | 0.00001 |
| OPA-S-2-F | CCS-185473-02-CN | BULKHEAD ADAPTER | 1 | 1 |
| | BAG-SS-06X08-Z | PACKAGING BAG | 0.02 | 0.02 |
| | LABEL-4X2 | LABEL | 0 | 0.00001 |
| OPA-D-1-F | CCS-185473-03-CN | BULKHEAD ADAPTER | 1 | 1 |
| | BAG-SS-06X08-Z | PACKAGING BAG | 0.04 | 0.04 |
| | LABEL-4X2 | LABEL | 0 | 0.00002 |
| OPA-D-2-F | CCS-185473-04-CN | BULKHEAD ADAPTER | 1 | 1 |
| | BAG-SS-06X08-Z | PACKAGING BAG | 0.04 | 0.04 |
| | LABEL-4X2 | LABEL | 0 | 0.00002 |

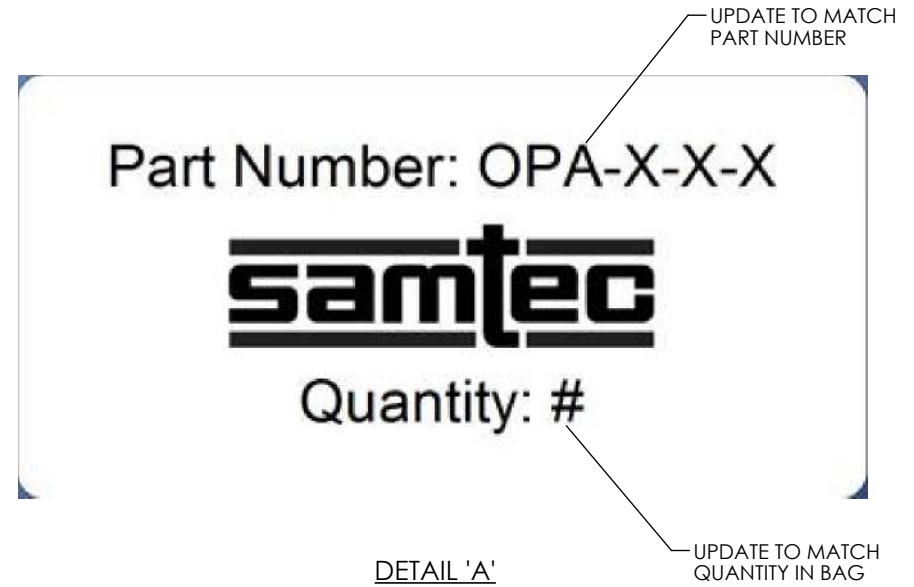
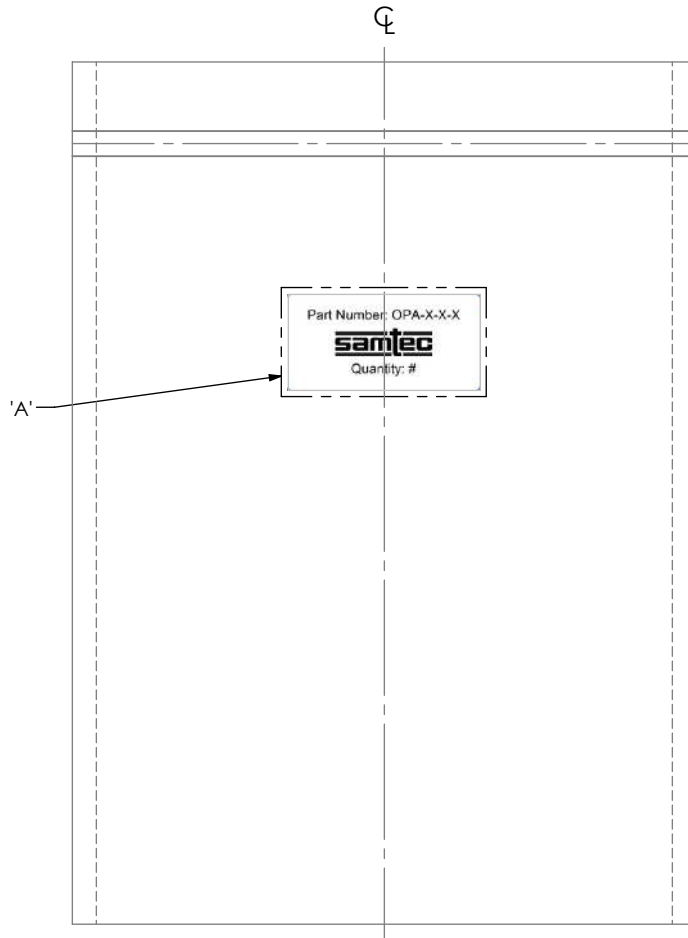

| PACKAGING QUANTITY | |
|--------------------|-------------|
| PART NUMBER | MAX PER BAG |
| OPA-S-1-F | 50 |
| OPA-S-2-F | 50 |
| OPA-D-1-F | 25 |
| OPA-D-2-F | 25 |

| | |
|--|--|
| <p>PROPRIETARY NOTE</p> <p>THIS DOCUMENT CONTAINS INFORMATION CONFIDENTIAL AND PROPRIETARY TO SAMTEC, INC. AND SHALL NOT BE REPRODUCED OR TRANSFERRED TO OTHER DOCUMENTS OR DISCLOSED TO OTHERS OR USED FOR ANY PURPOSE OTHER THAN THAT WHICH IT WAS OBTAINED WITHOUT THE EXPRESSED WRITTEN CONSENT OF SAMTEC, INC.</p> | <p>samtec</p> <p>520 PARK EAST BLVD, NEW ALBANY, IN 47150 PHONE: 812-944-6733 FAX: 812-948-5047 e-Mail info@SAMTEC.com code 55322</p> |
| | <p>DESCRIPTION: OPTICAL PANEL ADAPTER</p> <p>DWG. NO. OPA-X-X-X-XX</p> <p>BY: JEAN W. 02/05/2015 SHEET 3 OF 3</p> |