

4

3

2

1

THIS DRAWING IS UNPUBLISHED. RELEASED FOR PUBLICATION, 19 .
 © COPYRIGHT 19 BY AMP INCORPORATED. ALL RIGHTS RESERVED.

LOC	DIST	REVISIONS			
P	LTR	DESCRIPTION	DATE	DWN	APVD
AF	50	C	REV PER 063A-0428-00	27JUN00	JR GP

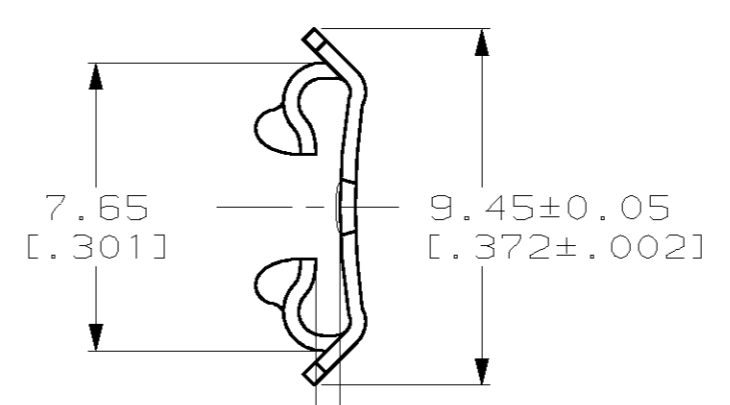
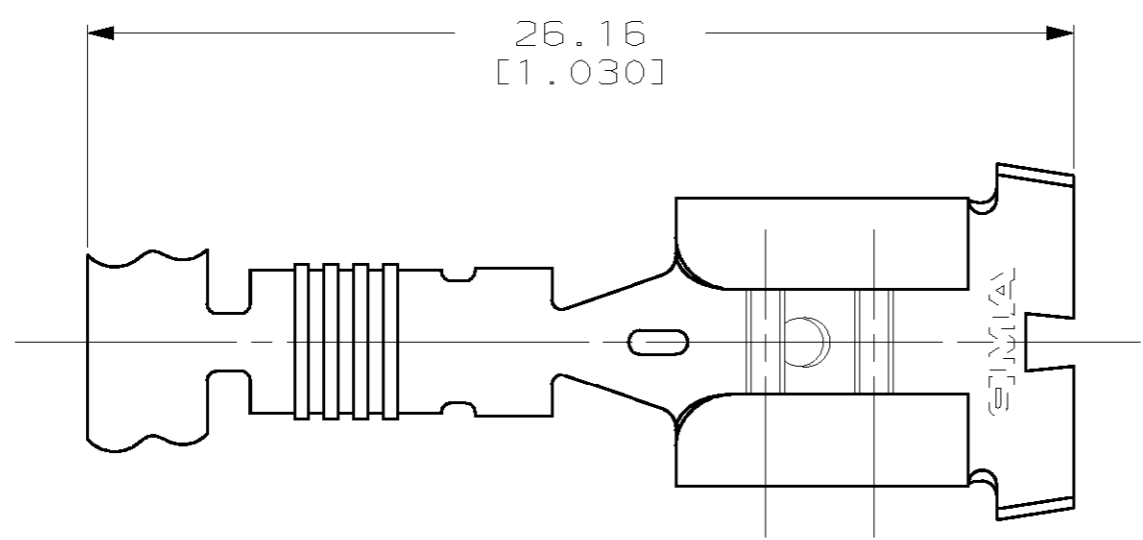

1 CONTINUOUS STRIP ON REEL.

FITS 6.35 [.250] SERIES FASTON™ TAB

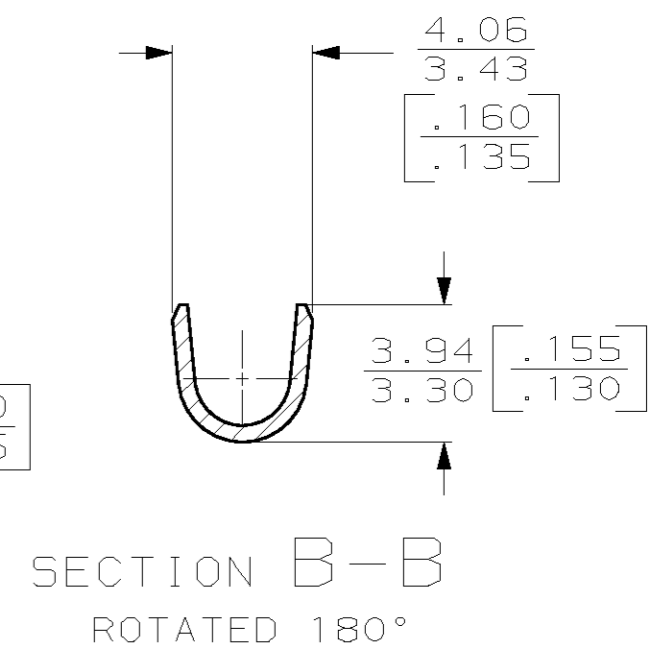
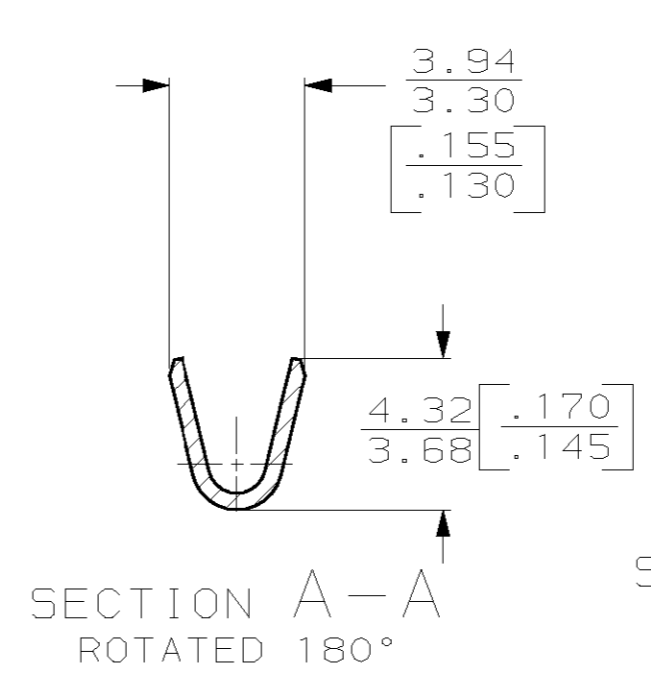
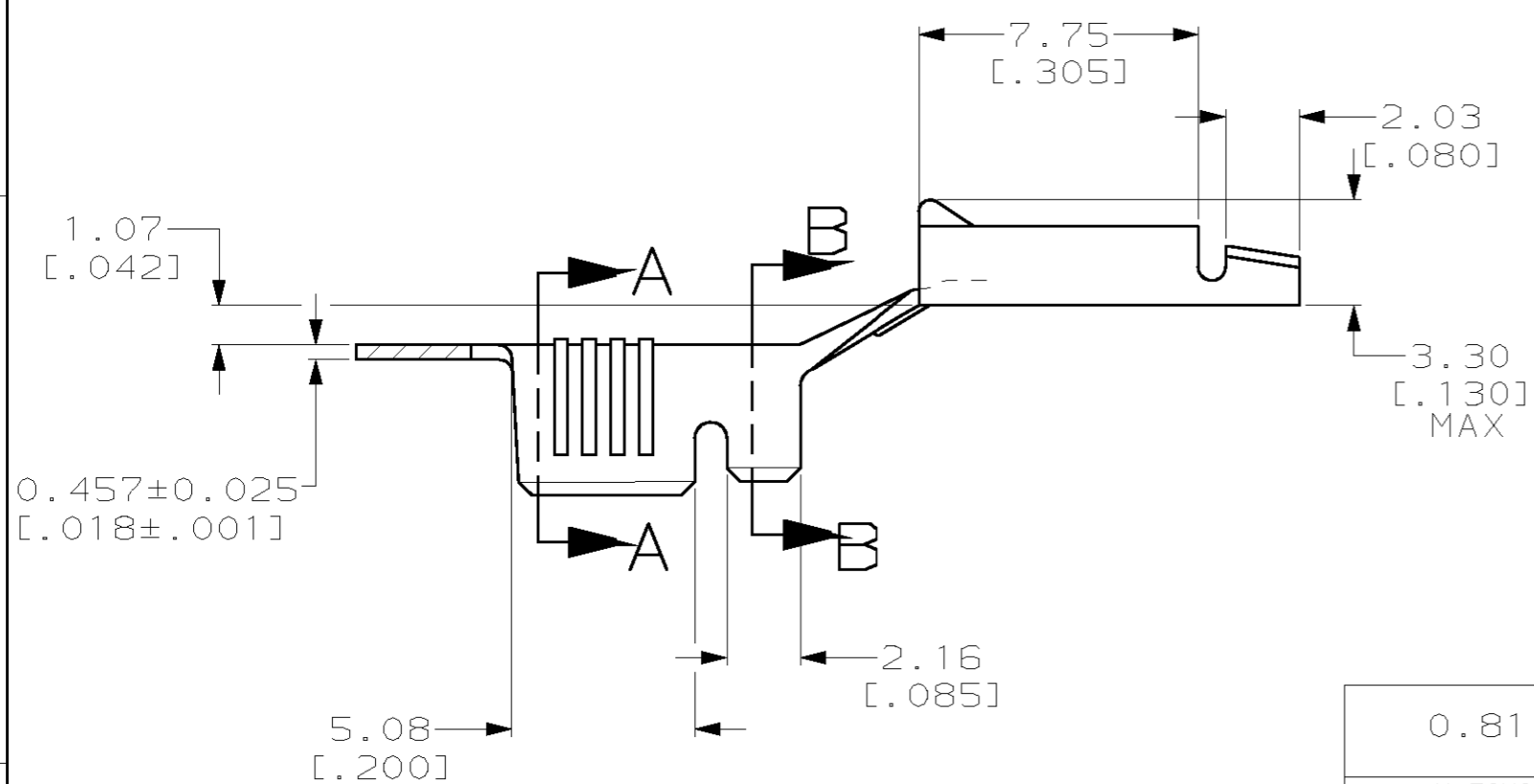

0.81 [.032]	1.52-2.79 [.060-.110] DIA	18-14 AWG	1217158-1
MATING TAB THK ±0.025 [.001]	INSULATION RANGE	WIRE RANGE	PART NUMBER

THIS DRAWING IS A CONTROLLED DOCUMENT.		DWN JR RUTH 20MAY99	AMP AMP Incorporated Harrisburg, PA 17105-3608
DIMENSIONS: mm [INCHES]		CHK MS FEHER 20MAY99	
TOLERANCES UNLESS OTHERWISE SPECIFIED:		APVD DON DECKER 20MAY99	NAME
0 PLC ±-		PRODUCT SPEC	STATOR RECEPTACLE
1 PLC ±-		APPLICATION SPEC	
2 PLC ±0.25 [.010]		WEIGHT -	SIZE A3
3 PLC ±-		CUSTOMER DRAWING	CAGE CODE 00779
4 PLC ±-			DRAWING NO C-1217158
ANGLES ±-			RESTRICTED TO -
MATERIAL #4 HD BRASS	FINISH 0.002032 [.000080] MIN TIN PLATE	SCALE 5:1	SHEET 1 OF 1
		REV C	