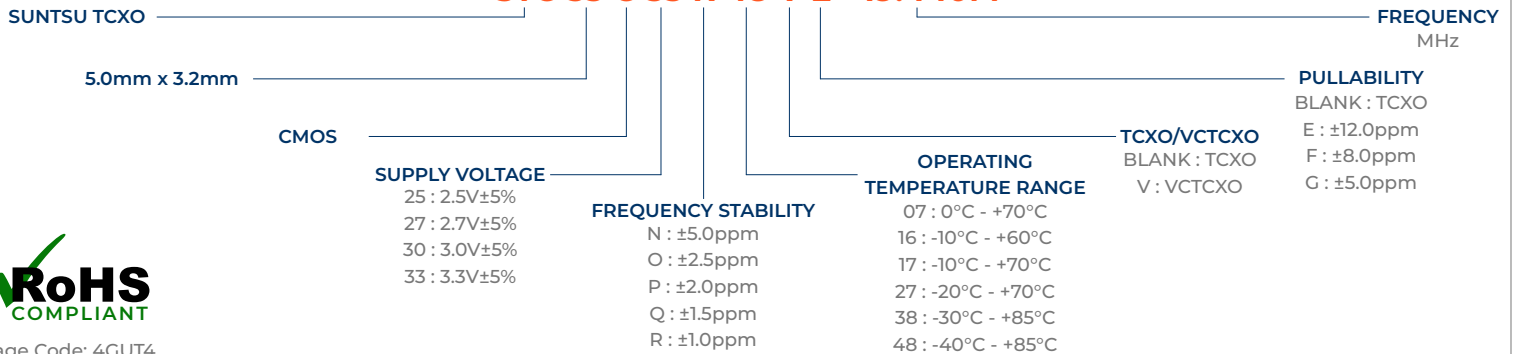

Features
<ul style="list-style-type: none"> <li>±1.0ppm (Frequency Stability) Available</li> <li>CMOS</li> <li>(VC)TCXO</li> <li>Tape and Reel</li> </ul>

Applications
<ul style="list-style-type: none"> <li>Base Stations</li> <li>IP networking</li> <li>Cellular and Cordless Phones</li> </ul>

**Part Numbering Guide**
**STC 53 C 33 R 48 V E - 19.440M**

Cage Code: 4GUT4

To customize your parameters contact a Suntsu representative.

Electrical Parameters	Units	Minimum	Typical	Maximum	Remarks
Frequency Range	MHz	6		40	
Frequency Tolerance at +25°C	ppm	-1.5		+1.5	1 hour after Reflow
Freq. Stability vs. Op Temp.	ppm	-1.0		+1.0	See part numbering guide for options.
Freq. Stability vs. Supply Voltage	ppm	-0.3		+0.3	V <sub>DD</sub> ±5% Change
Freq. Stability vs. Load	ppm	-0.3		+0.3	±5% Change
Freq. Stability vs. Aging	ppm	-1.0		+1.0	1 Year
Operating Temperature	°C	-40		+85	See part numbering guide for options.
Storage Temperature	°C	-55		+125	
Supply Voltage (V <sub>DD</sub> )	V	3.135	3.3	3.465	See part numbering guide for options.
Current (I <sub>DD</sub> )	mA			6	
Current Voltage (VC, VCTCXO)	V	0		V <sub>DD</sub>	Center Voltage: V <sub>DD</sub> *50%
Pullability (VCTCXO)	ppm	±5.0		±12.0	See part numbering guide for options.
Linearity (VCTCXO)	%			10	
Output Load (CMOS)	pF			15	
Output Logic HIGH Level (V <sub>OH</sub> )	V	0.8*V <sub>DD</sub>			
Output Logic LOW Level (V <sub>OL</sub> )	V			0.2*V <sub>DD</sub>	
Rise (T <sub>R</sub> ) And Fall (T <sub>F</sub> ) Time	ns			5	
Symmetry (Duty Cycle)	%	40		60	
Start-Up Time	ms			3	
VC Input Impedance (VCTCXO)	kΩ	100			
Phase Noise (Typical) 10Hz Offset	dBc/Hz		-85		
Phase Noise (Typical) 100Hz Offset	dBc/Hz		-115		
Phase Noise (Typical) 1KHz Offset	dBc/Hz		-135		
Phase Noise (Typical) 10KHz Offset	dBc/Hz		-145		
Phase Noise (Typical) 100KHz Offset	dBc/Hz		-150		

**Outline Drawing & Land Pattern**

All dimensions are in millimeters (mm) unless otherwise noted. Drawings are not to scale.

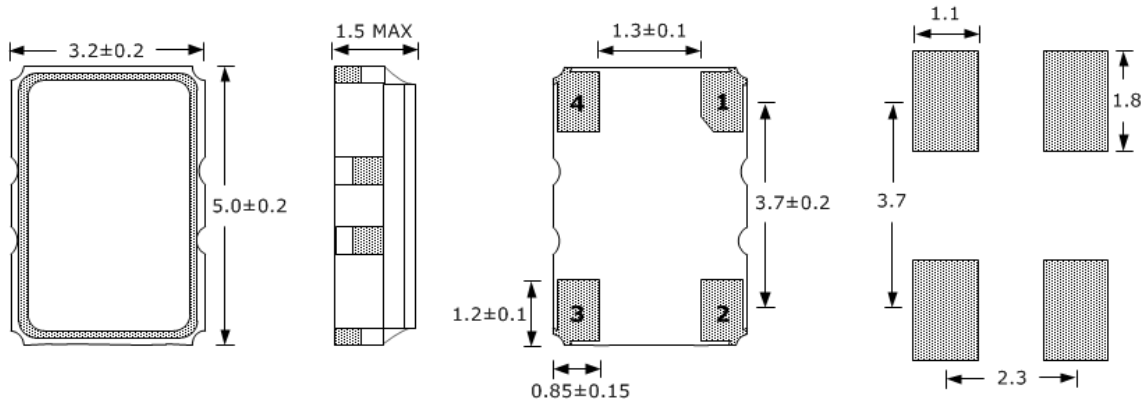

PIN	FUNCTION
1	$V_{CC}$ (VCTCXO) or N/C (TCXO)
2	GND
3	OUTPUT
4	$V_{DD}$

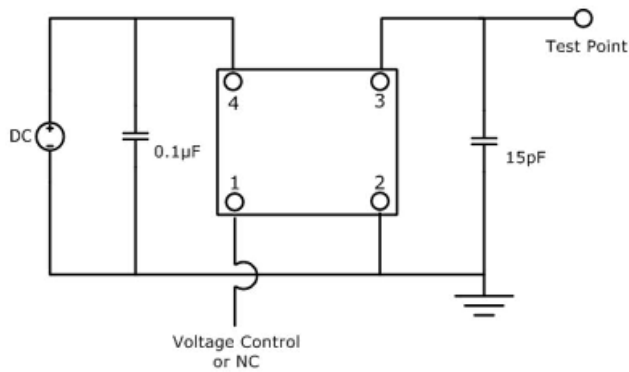
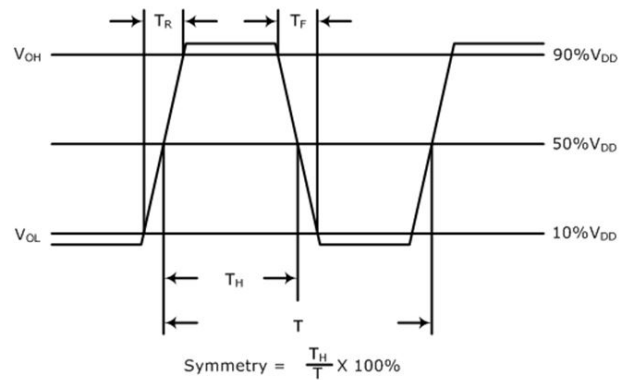
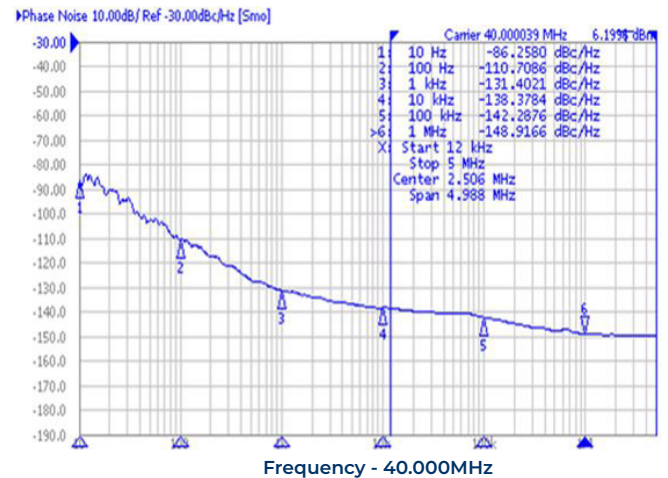
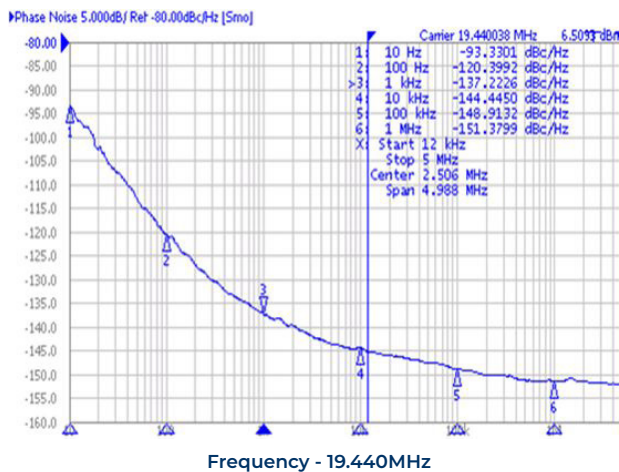
**Test Circuit (CMOS)**

**Waveform (CMOS)**

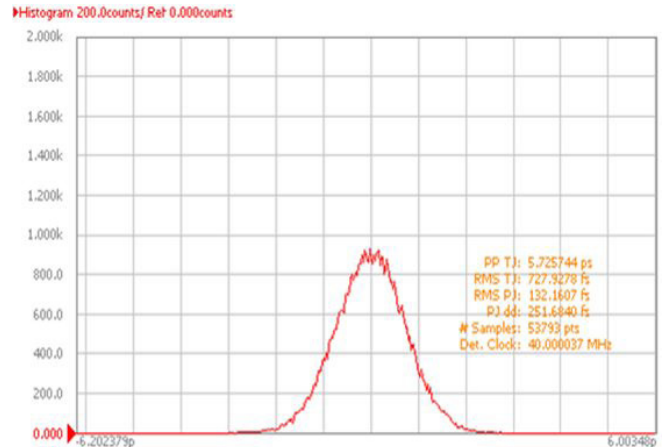
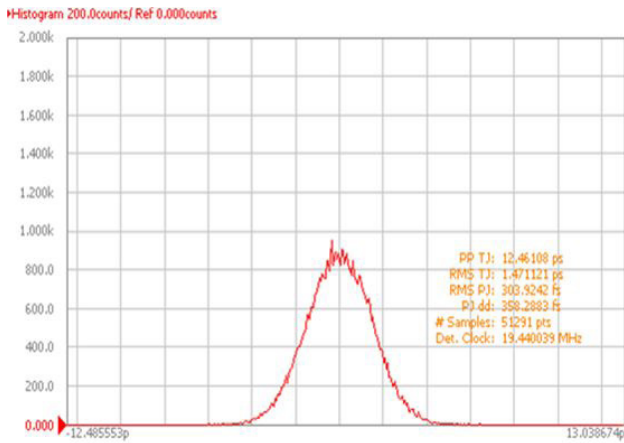
**Typical Phase Noise Performance (Measured By Agilent E5052A)**

Typical Jitter Performance (Measured By Agilent E5052A)

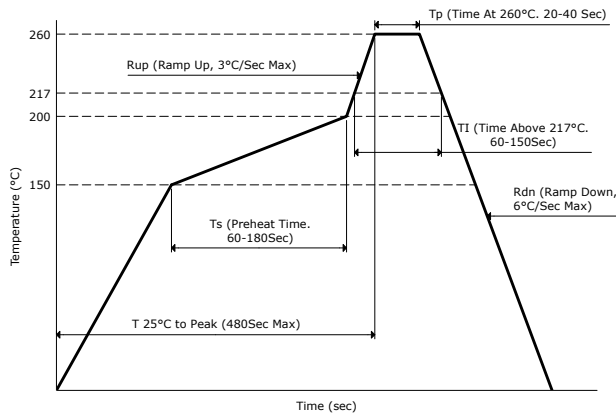

Reflow Profile



Part Marking

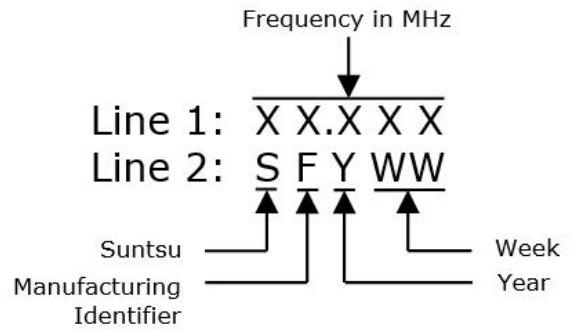

Tape And Reel Dimensions

All dimensions are in millimeters (mm) unless otherwise noted. Drawings are not to scale.

3,000pcs/Reel

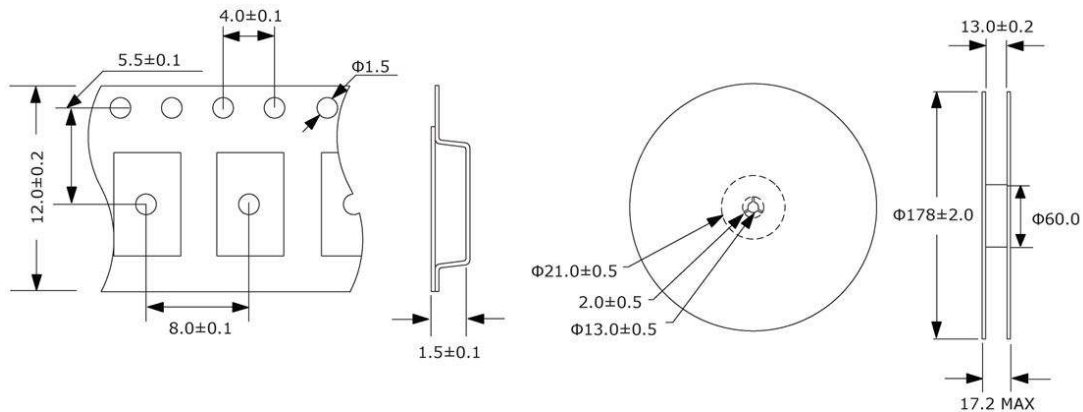

Environmental Specifications		Mechanical Specifications	
Temperature Cycling	MIL-STD-883, Method 1010, Condition B	Mechanical Shock	MIL-STD-202, Method 213, Condition B
Fine Leak Test	MIL-STD-883, Method 1014, Condition A	Vibration	MIL-STD-883, Method 2007, Condition A
Gross Leak Test	MIL-STD-883, Method 1014, Condition C	Moisture Resistance	MIL-STD-883, Method 1004
Solderability	MIL-STD-883, Method 2003	Resistance to Solvents	MIL-STD-202, Method 215
Moisture Sensitivity	J-STD-020, MSL 1	Resistance to Soldering Heat	MIL-STD-202, Method 210, Condition K