

TLS202A1

Demonstration Board Manual

Demonstration Board Manual

Rev. 1.0, 2013-06-12

Automotive Power

1 Introduction

The TLS202A1 application board is a demonstration of the Infineon low drop out linear voltage post regulator. The TLS202A1 is the ideal IC to supply regulated voltage for general ECU's, safety and infotainment applications. The adjustable output voltage makes the TLS202A1 suitable of supplying the majority of standard applications.

This application note contains information for the TLS202A1 Demonstration Board.

1.1 General Description

The TLS202A1 is a monolithic integrated adjustable linear voltage post regulator for load currents up to 150 mA. The IC regulates an input voltage V_I in the range of $2.7\text{ V} \leq V_I \leq 18\text{ V}$ to an adjustable output voltage of 1.2 V to 5.25 V with a precision of $\pm 3\%$. The TLS202A1 is especially designed for applications requiring very low standby currents, e.g. with a permanent connection to preregulators like DCDC converters. The regulator is not designed to operate with a direct connection to the battery. The device is available in a very small surface mounted PG_SCT595 package and is designed for the harsh environment of automotive applications. Therefore it is protected against overload, short circuit and overtemperature conditions by the implemented output current limitation and the overtemperature shutdown circuit. The TLS202A1 can be also used in all other applications requiring a stabilized voltage of 1.2 V to 5.25 V.

By default the Demonstration Board is equipped with a resistor divider adjusting the output voltage to 3.3 V. By connecting the Jumper "JP_1.2V" the output voltage can be configured to the internal reference voltage of 1.2 V, which corresponds to the lowest achievable nominal output voltage.

For more detailed information please see also TLS202A1 data sheet [\[1\]](#).

1.2 TLS202A1 Feature List

- Output Voltage: adjustable between 1.2 V to 5.25 V
- Output Voltage Accuracy of $\pm 3\%$
- Output Currents up to 150 mA
- Extended Input Voltage Operating Range of 2.7 V to 18 V
- Low Dropout Voltage: typ. 290mV
- Very Low Current Consumption: typ. 50 μA
- Very Low Shutdown Current: typ. 0.01 μA
- Very High PSRR: typ. 65dB at 10 kHz
- Output Current Limitation
- Short Circuit protected
- Overtemperature Shutdown
- Wide Temperature Range From $-40\text{ }^\circ\text{C}$ up to $150\text{ }^\circ\text{C}$
- Suitable for Use in Automotive Electronics as Post Regulator
- Green Product (RoHS compliant)
- AEC Qualified

1.3 Block Diagram

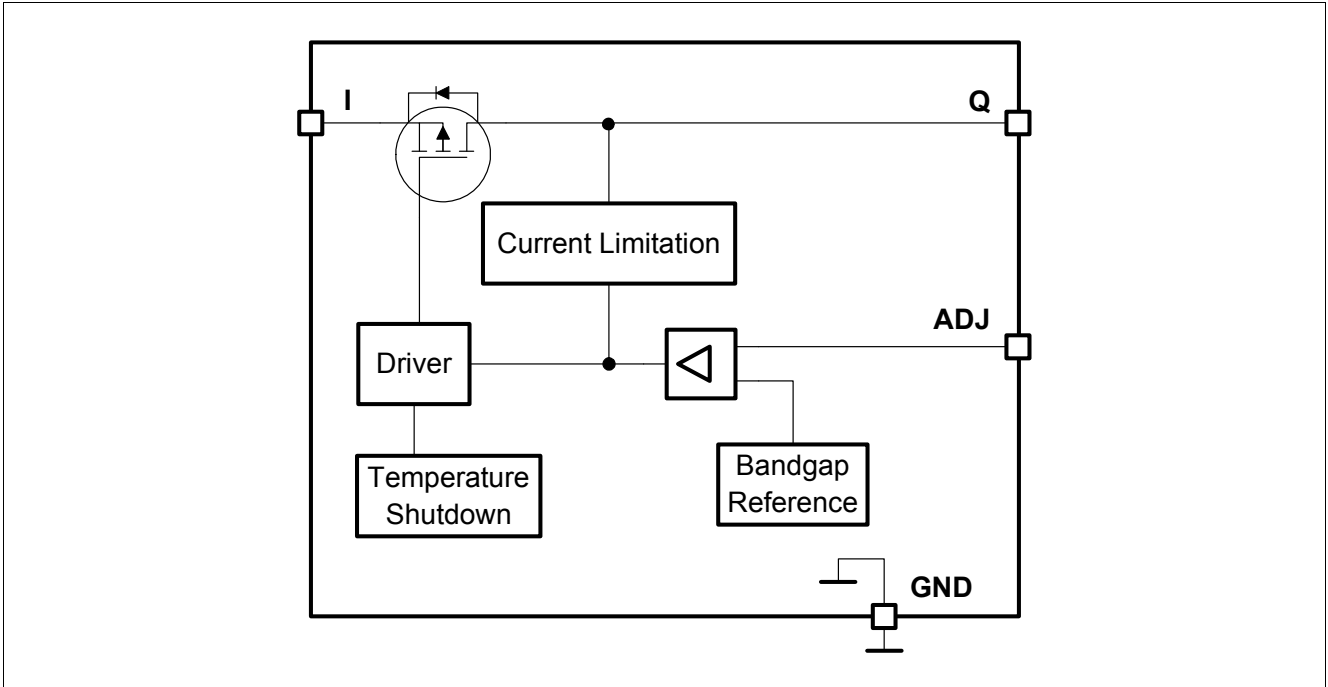

Figure 1 Block Diagram of TLS202A1

2 Demonstration Board

The TLS202A1 Demonstration Board is equipped by default with TLS202A1 and all necessary components.



Figure 2 TLS202A1 Demo Board

2.1 Operating Conditions

To avoid any electrical damage of the Demonstration Board, the maximum operating range defined in [Table 1](#) must be followed.

Table 1 Operating Range¹⁾

Parameter	Symbol	Limit Values		Unit	Note
		Min.	Max.		
Board Supply ²⁾	VIN	0	18	V	Power supply
Regulator Output	VQ	0	5.5 ³⁾	V	Regulated output for loads up to 150mA
Reference Voltage	ADJ	0	1.2	V	Voltage at the ADJ Pin indicates V_{ref}
Ground	GND	0	0	V	System GND

1) The Demonstration Board operates at ambient temperature of 25°C.

2) Functional input voltage range starts from 2.7 V to 18 V.

3) Nominal output voltage depends on the resistor divider applied at the ADJ-Pin of TLS202A1.

2.2 Adjustment of Nominal Output Voltage

The TLS202A1 can be adjusted to any desired output voltage between 1.2 V and 5.25 V by dimensioning the resistor divider at the ADJ-Pin accordingly. The resistor divider for a specific output voltage can be calculated according to [Equation \(1\)](#). The current I_{ADJ} , which flows into the ADJ-Pin, can be neglected, if [Equation \(2\)](#) is observed. V_{ADJ} is typically 1.2 V.

$$\frac{R_1}{R_2} = \frac{V_Q}{V_{ADJ}} - 1 \tag{1}$$

$$R_2 \leq 50k\Omega \tag{2}$$

The following table provides some examples for resistor dividers configuring the device for a special nominal output voltages.

Table 2 Examples for Resistor Dividers using resistors up to E48 series

Desired Output Voltage	Value for R1	Value for R2	Result of $V_{Q,nom}$
1.2 V	Short Circuit / 0 Ω	Open Circuit	1.2 V
1.8 V	24.9 k Ω	50 k Ω	1.798 V
2.85 V	59 k Ω	43 k Ω	2.847 V
3.0 V	75 k Ω	50 k Ω	3.0 V
3.3 V (default)	82 k Ω (E24 1%)	47 k Ω (E24 1%)	3.294 V
5.0 V	147 k Ω	46.4 k Ω	5.002 V

2.3 Signal Adaption

For easy signal adaption e.g. connecting probes for an oscilloscope, test point connectors indicated by "TP_xxx", can be found at the Demonstration Board.

Table 3 Signals

Connector	Accessible Signal
TP_VIN	- I (power supply)
TP_VQ	- Q (output voltage)
TP_EN/ADJ	- ADJ (reference voltage of the IC)
TP_GND	- GND (chip ground connection)

3 Schematic and Layout

3.1 Schematic

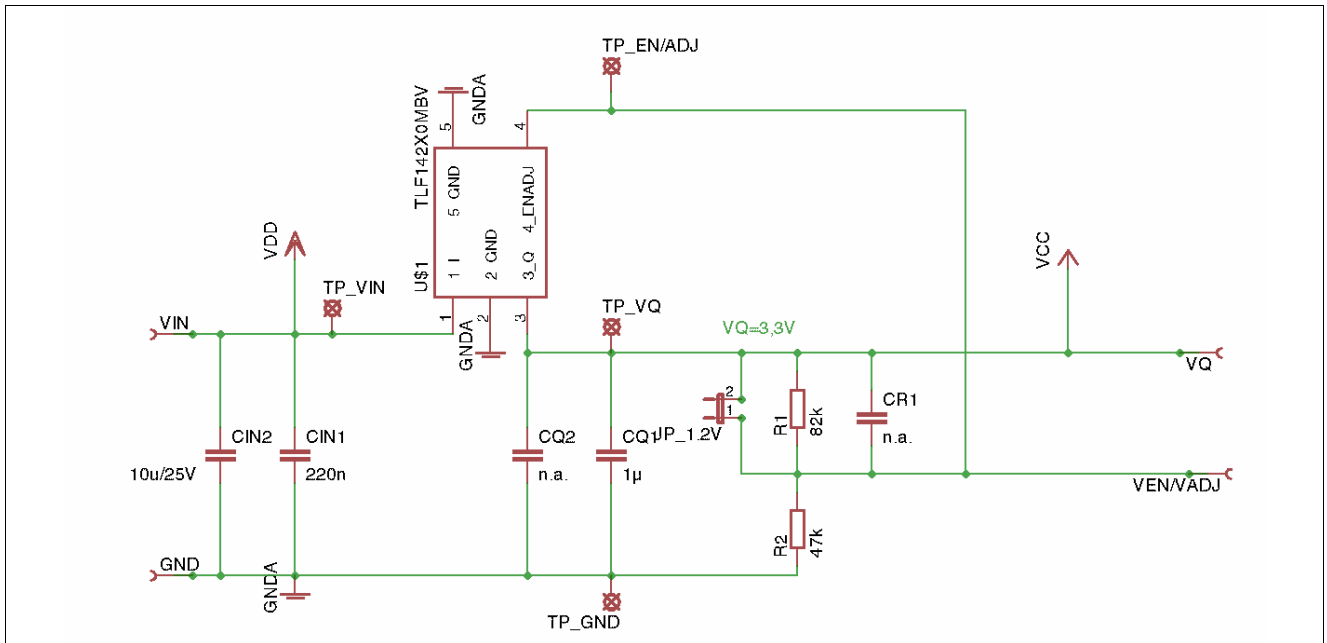

Figure 3 Schematic of TLS202A1 Demonstration Board

3.2 Layout

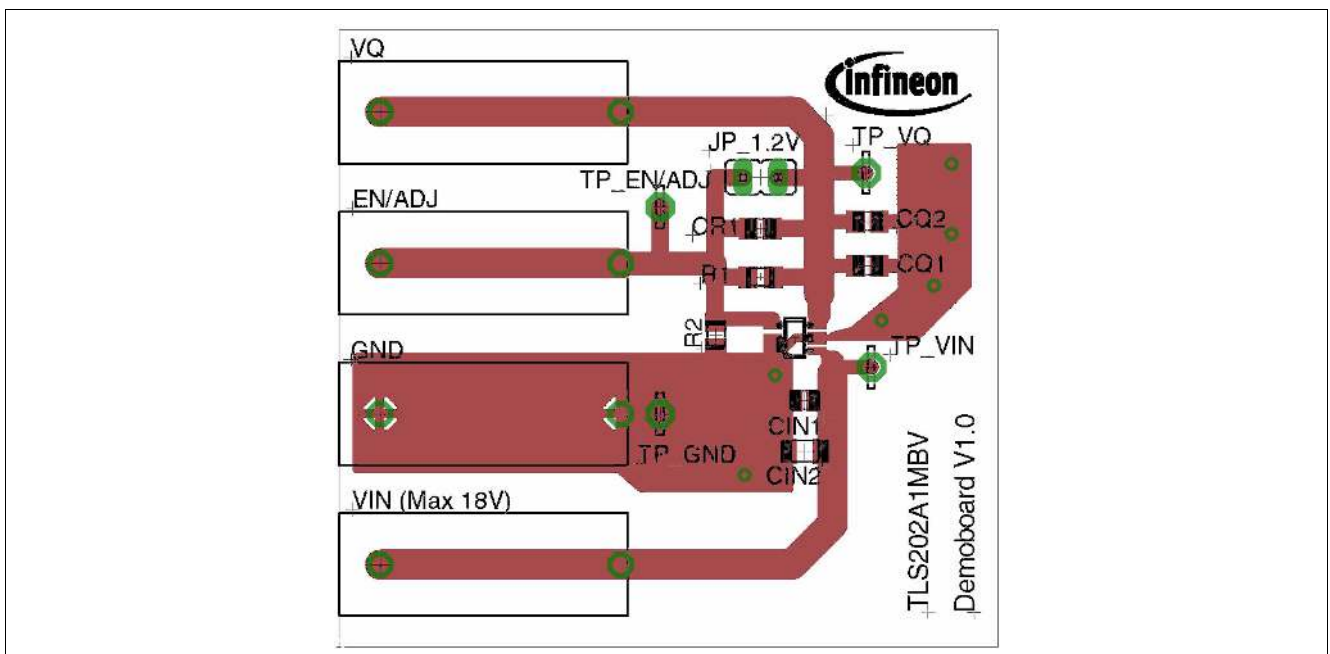

Figure 4 Top Layer of TLS202A1 Demonstration Board

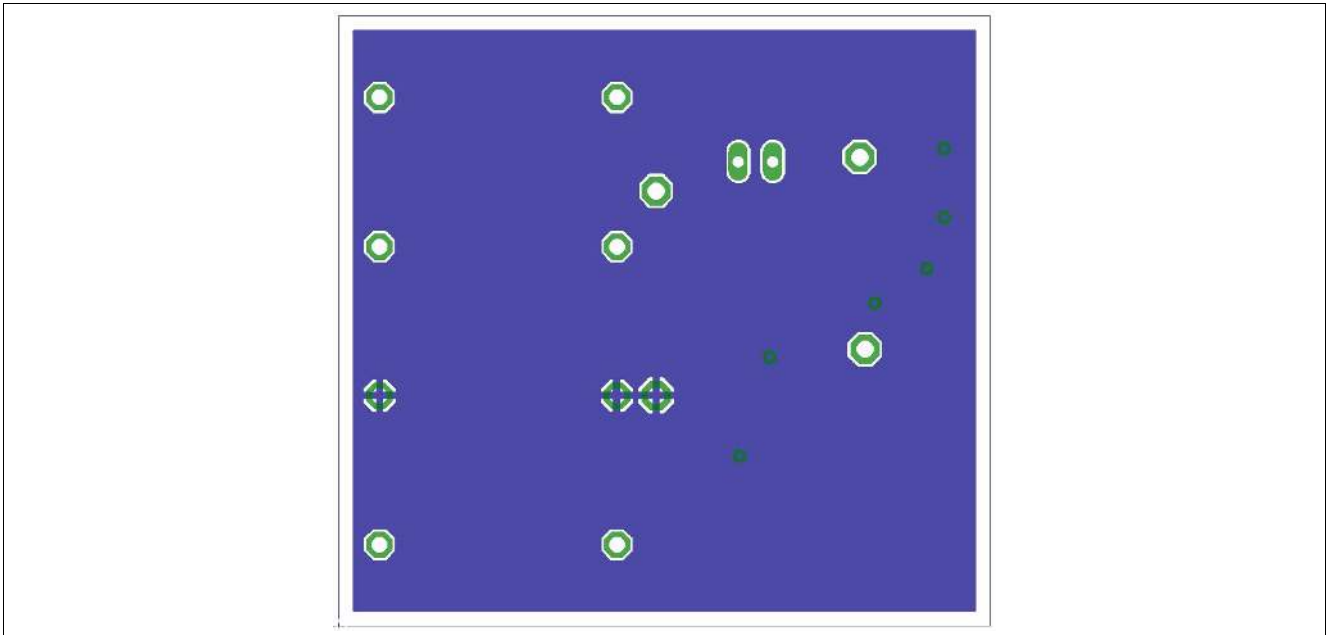

Figure 5 Bottom Layer of TLS202A1 Demonstration Board

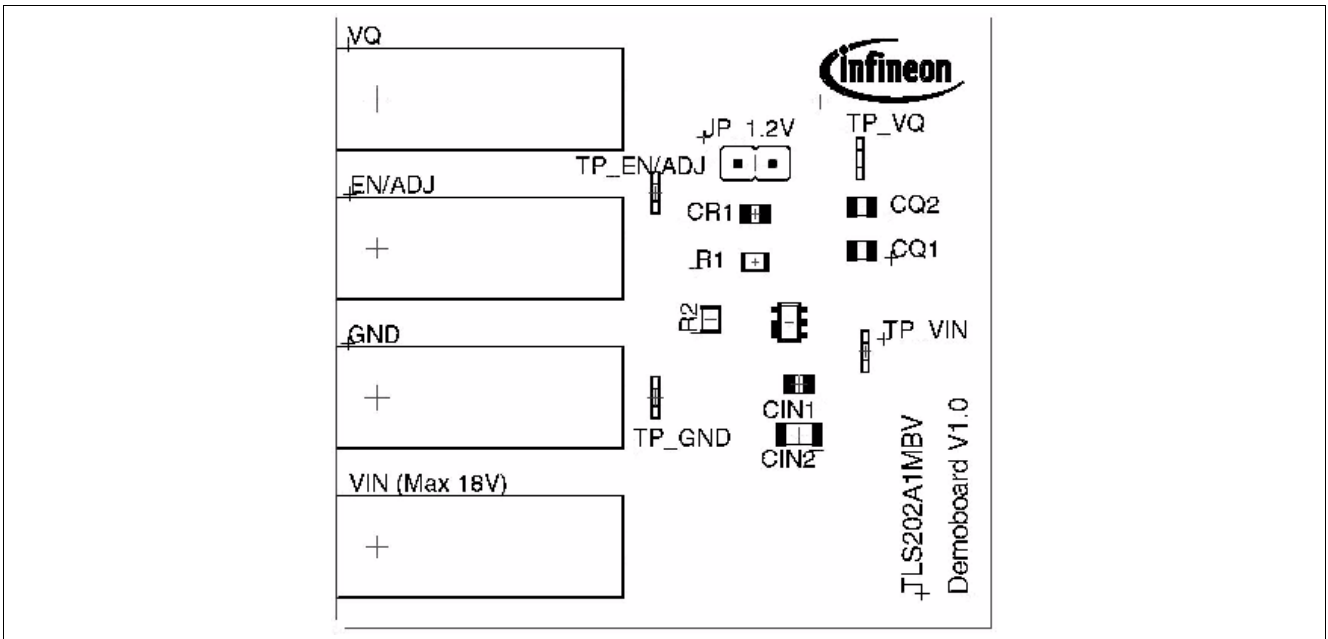

Figure 6 Top Layer components of TLS202A1 Demonstration Board

4 Bill of Material

Table 4 Bill of Material

Part	Value	Package
VIN	Banana jack	BABU4MM
VW	Banana jack	BABU4MM
EN/ADJ	Banana jack	BABU4MM
GND	Banana jack	BABU4MM
R1	82 k Ω (E24 1%)	R0805
R2	47 k Ω (E24 1%)	R0805
CR1	not placed	R0805
CIN1	220 nF / 25 V (X7R)	C0805
CIN2	10 μ F / 25 V (X7R)	C1206
CQ1	1 μ F / 16 V (X7R)	C0805
CQ2	not placed	C0805
TP_VIN		
TP_VQ		
TP_EN/ADJ		
TP_GND		
IC1	TLS202A1MBV33	PG_SCT595

5 General Information

5.1 Restrictions

This Application Board is offering limited features allowing you only to evaluate and test the Infineon products. The Demonstration Board is not an end product (or finished appliance), nor is it intended or authorized by Infineon to be integrated into end products. You are not authorized to use the Demonstration Board in any production system.

5.2 Additional Information

[1] TLS202A1 Data Sheet (For further information you may contact <http://www.infineon.com/>)

5.3 Revision History

Revision	Date	Changes
1.0	2013-05-27	Initial version

Edition 2013-06-12

**Published by
Infineon Technologies AG
81726 Munich, Germany**

**© 2013 Infineon Technologies AG
All Rights Reserved.**

LEGAL DISCLAIMER

THE INFORMATION GIVEN IN THIS APPLICATION NOTE IS GIVEN AS A HINT FOR THE IMPLEMENTATION OF THE INFINEON TECHNOLOGIES COMPONENT ONLY AND SHALL NOT BE REGARDED AS ANY DESCRIPTION OR WARRANTY OF A CERTAIN FUNCTIONALITY, CONDITION OR QUALITY OF THE INFINEON TECHNOLOGIES COMPONENT. THE RECIPIENT OF THIS APPLICATION NOTE MUST VERIFY ANY FUNCTION DESCRIBED HEREIN IN THE REAL APPLICATION. INFINEON TECHNOLOGIES HEREBY DISCLAIMS ANY AND ALL WARRANTIES AND LIABILITIES OF ANY KIND (INCLUDING WITHOUT LIMITATION WARRANTIES OF NON-INFRINGEMENT OF INTELLECTUAL PROPERTY RIGHTS OF ANY THIRD PARTY) WITH RESPECT TO ANY AND ALL INFORMATION GIVEN IN THIS APPLICATION NOTE.

Information

For further information on technology, delivery terms and conditions and prices, please contact the nearest Infineon Technologies Office (www.infineon.com).

Warnings

Due to technical requirements, components may contain dangerous substances. For information on the types in question, please contact the nearest Infineon Technologies Office.

Infineon Technologies components may be used in life-support devices or systems only with the express written approval of Infineon Technologies, if a failure of such components can reasonably be expected to cause the failure of that life-support device or system or to affect the safety or effectiveness of that device or system. Life support devices or systems are intended to be implanted in the human body or to support and/or maintain and sustain and/or protect human life. If they fail, it is reasonable to assume that the health of the user or other persons may be endangered.