

LAN Modular Jack Connectors

XM9B

Compact LAN Modular Jack Connectors

- Category 5e transmission performance met for 1,2-3,6 pairs. (Verified with connection to OMRON XS5W-T421.)
- Models available with and without indicators to match application needs.
- For models with indicators, no space is required on the side of the case to install a separate indicator, which saves you space.
- Structure provides EMI countermeasures.
- Lead-free.
- See the "Standards certification / conformity list" for information on conformity to certification standards.



Model Number Legend

XM9B-1 8 8 4 4 -1 □
 (1) (2) (3) (4) (5) (6) (7)

(1) Number of Plungers

Code	Number of Plungers
1	1 plungers

(2) Number of Poles

Code	No. of Contacts
8	8

(3) Number of Mounted Contacts

Code	Installed Number
8	8

(4) Contact Plating Specification

Code	Specification
4	Gold Flash Plating

(5) Terminal Shape

Code	Shape
4	Side entry (right-angle terminals)

(6) Shielding Plate Specification

Code	Specification
1	With shielding plate

(7) Indicator Specification

Code	Specification
0	Without indicator
1	With indicator

Ratings and Characteristics

Rated current	1.5A
Rated voltage	250 VAC
Contact resistance	20 mΩ max.
Insulation resistance	500 MΩ min.
Withstand voltage	500 VAC for 1 min (leakage current: 0.5 mA max.)
Insertion durability	750 times
Operating temperature	-45 to 80°C (With no icing at low temperature)

Note: Refer to the product specifications for details.

Materials and Finish

Housing	PBT resin (UL94 V-0)/black	
Contacts	Mating end	Phosphor bronze/nickel base, flash gold plated
	Terminals	Phosphor bronze/nickel base, flash gold plated
Shell	Brass/nickel plated	

Note: Refer to the product specifications for details.

Ordering Information

Appearance		
Indicator	Without indicator	With indicator
Model	XM9B-18844-10	XM9B-18844-11

XM9B

Dimensions

(Unit: mm)

XM9B-18844-10

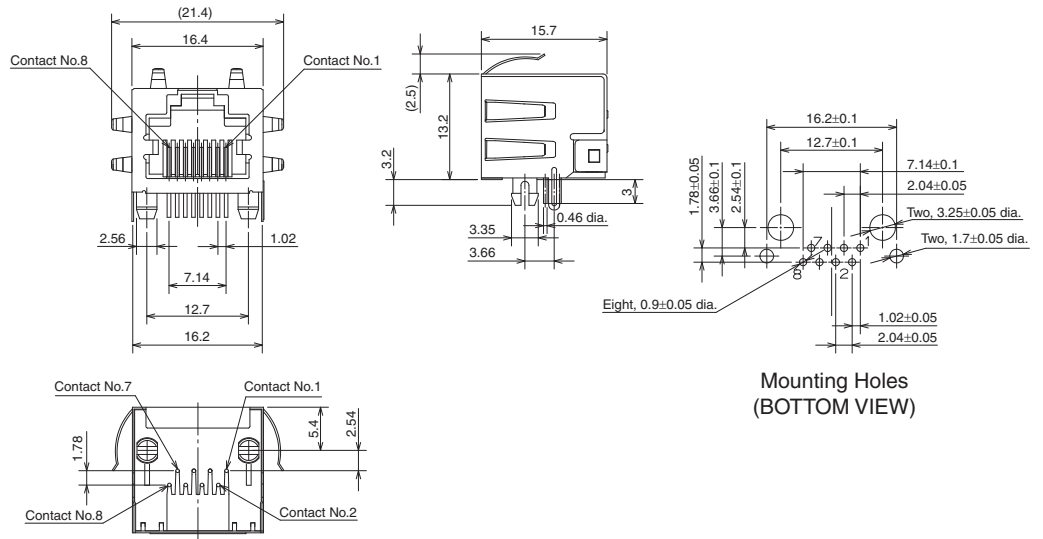

XM9B-18844-11

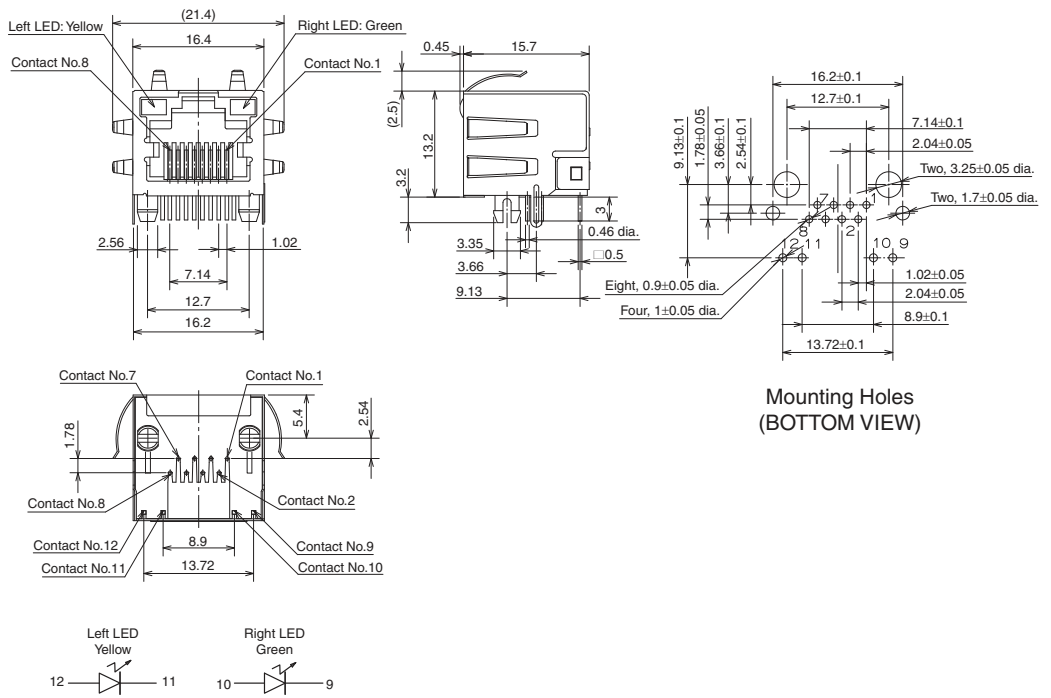

Safety Precautions

Precautions for Correct Use

Do not use the product in any atmosphere or environment that exceeds the ratings.

●Automatic Soldering

Automated Soldering Conditions (Jet Flow)

- (1) Soldering temperature: $250 \pm 5^{\circ}\text{C}$
- (2) Continuous soldering time: within 5 ± 1 s

●Storage

Do not store the Connectors in locations subject to dust or high humidity. Do not store the Connectors in locations close to sources of gasses such ammonia gas or sulfide gas.

●Terminal Shapes

The terminals will deform if they are subjected to an excessive load, which will in turn reduce solderability when mounting. Do not drop the Connectors or handle them carelessly. Do not connect anything when the Connectors are not mounted to a board. Doing so may deform the terminals.

●Using an Automatic Solder Bath

Mask the mating portion with tape before you perform automatic soldering to prevent flux or solder from entering the mating portion of the Connector. Select and use a suitable masking tape.

●Application Precautions

- Confirm that there is no excessive misalignment or inclination in the mating contact portion between the plug and socket before mating the Connector. Make sure that the Connector is mated all the way to the back. If the Connector is not mated all the way to the back, contact reliability may be lost.
- Do not apply an extreme load during Connector insertion or removal. The Connector may be damaged, and contact failure may result. Twist the plug and socket as little as possible when mating the Connector. Not doing so may deform the terminals or housing or crack the housing.
- Do not insert a foreign object, such as tweezers, into the Connector mating contact portion. Doing so may cause the plating to peel off or deform the terminals.

Please check each region's Terms & Conditions by region website.

OMRON Corporation

Electronic and Mechanical Components Company

Regional Contact

Americas

<https://www.components.omron.com/>

Asia-Pacific

<https://ecb.omron.com.sg/>

Korea

<https://www.omron-ecb.co.kr/>

Europe

<http://components.omron.eu/>

China

<https://www.ecb.omron.com.cn/>

Japan

<https://www.omron.co.jp/ecb/>