

# Thermofit<sup>®</sup> Molded Parts Specification Control Drawing

Part Number : 243A012 thru 022  
Description : Boot, 45°, Thick Wall

## NOTES

- All dimensions are in  $\frac{\text{inches}}{[\text{millimeters}]}$  ;  $\frac{\text{lbs}}{[\text{gms}]}$
- Dimensions appearing in table are as follows:  
a - As Supplied  
b - After Unrestricted Recovery
- Coating is optional. As supplied dimensions appearing in table are for uncoated parts. When coating is added, entry diameters will be reduced by .06 max.
- Molding ports are optional. When -00 modification number is specified molding ports will be located as shown.
- Weight shown in table of dimensions is based on polyolefin part.

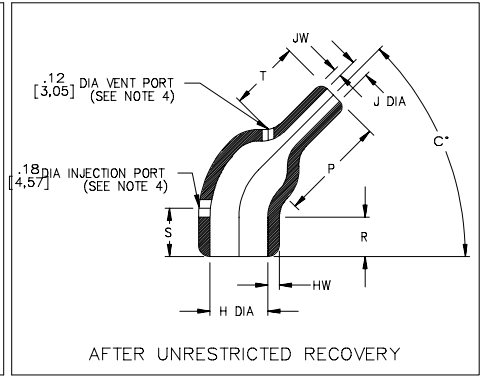
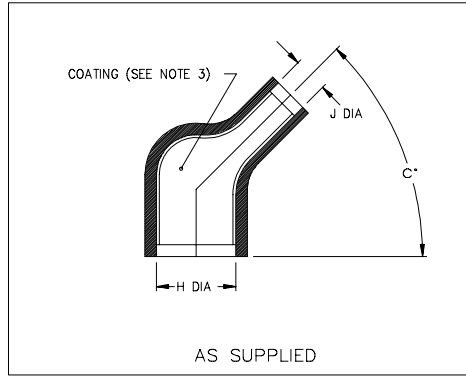

PART NUMBER	H		J		P	R	S	T	HW	JW	C°		Weight
	Min	Max	Min	Max	±10%	±10%	±10%	±10%	±20%	±20%	±10°	±5°	±10%
	a	b	a	b	b	b	b	b	b	b	a	b	b
243A012	.76 [19,3]	.56 [14,2]	.32 [8,1]	.16 [4,1]	.96 [24,4]	.38 [9,7]	.50 [12,7]	.63 [16,0]	.09 [2,29]	.08 [2,03]	45°	45°	.009 [4,1]
243A022	.94 [23,9]	.70 [17,8]	.46 [11,7]	.22 [5,6]	1.07 [27,2]	.38 [9,7]	.50 [12,7]	.85 [21,6]	.11 [2,79]	.075 [1,91]	45°	45°	.015 [6,8]

**Raychem**

RAYCHEM CORPORATION  
300 CONSTITUTION DRIVE  
MENLO PARK, CALIFORNIA 94025

Revision : L  
Date : 3/17/99

Part Number : 243A012 thru 022  
Description : Boot, 45°, Thick Wall

# Thermofit<sup>®</sup> Molded Parts Specification Control Drawing

Part Number : 243A012 thru 022  
Description : Boot, 45°, Thick Wall

MATERIAL DASH NO.	MATERIAL DESCRIPTION	RT SPEC	COATING SLASH NO.	COATING S NO.	COATING DESCRIPTION
-3	Polyolefin, Semi-rigid	RT-301	/42;/86	S-1017;S-1048	Adhesive
-4	Polyolefin, Flexible	RT-1304	/42;/86	S-1017;S-1048	Adhesive
-6	Silicone	RT-602	N/A		
-12	*VITON, Flexible	RT-1312	N/A		
-25	Elastomer, Fluid Resistant	RT-1325	/86	S-1048	Adhesive

\*VITON is a Registered Trademark of Dupont

## ORDERING INFORMATION

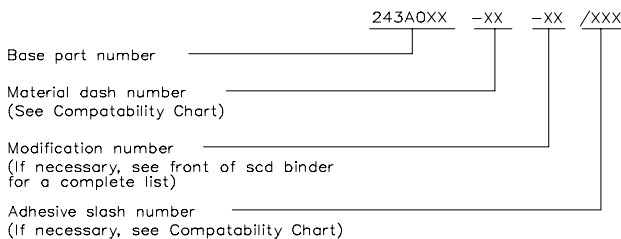

If this document is printed it becomes uncontrolled.  
Check for the latest revision.

THIS DRAWING IS SUBJECT TO CHANGE WITHOUT NOTICE; CONSULT YOUR  
NEAREST FIELD REPRESENTATIVE FOR CURRENT REVISION

**Raychem**

RAYCHEM CORPORATION  
300 CONSTITUTION DRIVE  
MENLO PARK, CALIFORNIA 94025

Revision : L  
Date : 3/17/99

Part Number : 243A012 thru 022  
Description : Boot, 45°, Thick Wall

CAD FILE MP99063