

## Features

- 2-stage operational amplifier as filter
- Built-in noise rejection circuit
- On-chip regulator
- Override function (PT8A2621 only)
- Synchronous with AC 220V/50Hz and 110V/60Hz
- Pulse output (PT8A2611) for TRIAC drive or level output (PT8A2621) for relay drive
- CDS to enable/disable output
- Adjustable output on time duration
- ON/AUTO/OFF selectable by MODE pin
- Auto-reset if the ZC signal disappears over 3 seconds
- 40 seconds warm-up
- Quick check mode for initial installation
- Operating voltage: 5V
- Stand-by current: 80μA
- Package: 16-pin DIP and 16-pin SOP

## Applications

- Energy saving auto-switch in Garden, kitchen, bathroom, corridor, storage or yard
- Auto light in meeting room

## General Description

The PT8A2611 and PT8A2621 are low power mixed signal CMOS LSI designed for the automatic lamp control using PIR sensor as motion detector.

With on chip noise filter and voltage regulator, the IC provides stable operations throughout temperature range. CDS input to disable day time operation is desired.

## Function Comparison

	Override	CDS feedback	Output
<b>PT8A2611</b>	No function	Internal	TRIAC
<b>PT8A2621</b>	Twice	With external components (see Fig. 10, D9 and R15)	RELAY

## Ordering Information

Part Number	Package
PT8A2611P / PT8A2621P	Lead free 16 - Pin DIP
PT8A2611W / PT8A2621W	Lead free and Green 16 - Pin SOIC
PT8A2611DE / PT8A2621DE	Die Form

**Note:** Adding E= Pb-free or Pb-free and Green

Adding X suffix=Tape/Reel

## Block Diagram

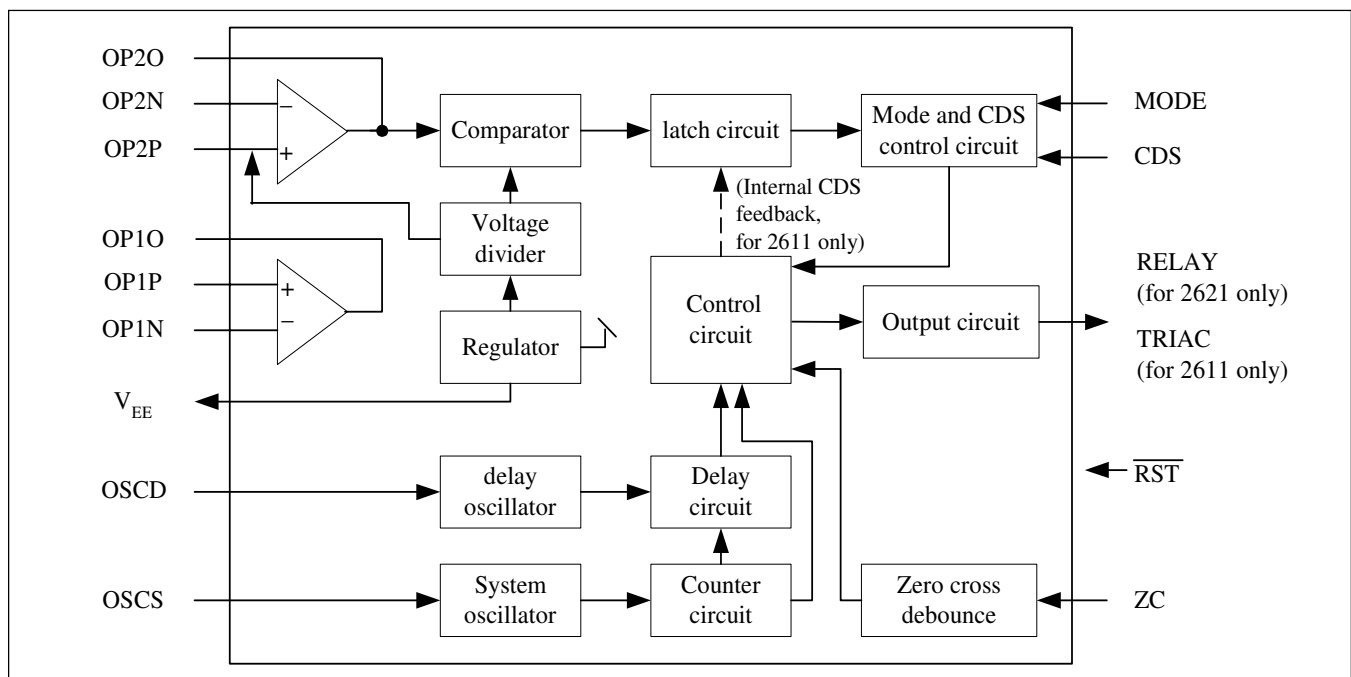

## Pad Location

### Pad Location of PT8A2611DE

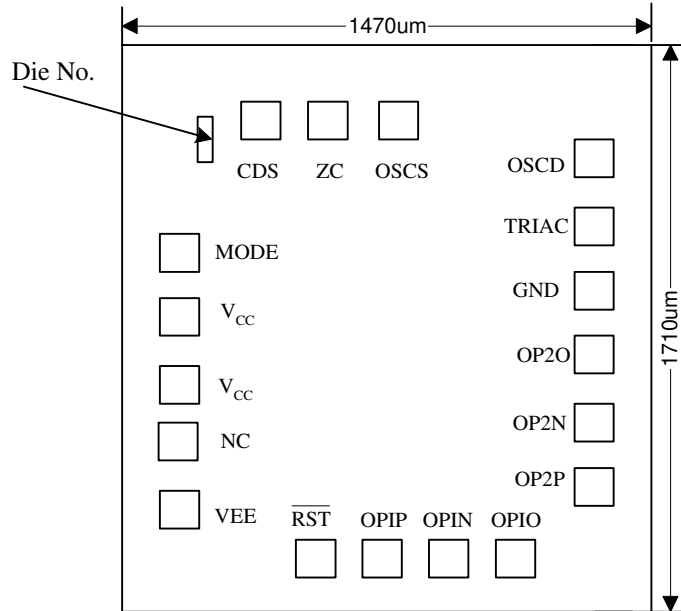

Pad Coordinate					
Pad Name	X Coordinate	Y Coordinate	Pad Name	X Coordinate	Y Coordinate
GND	570	65.4	NC	570	-268.6
TRIAC	570	-101.6	V <sub>EE</sub>	-570	232.4
OSCD	570	399.4	RST	303.9	-687.2
OSCS	570	232.4	OP1P	-44.8	689.2
ZC	-378.8	689.2	OP1N	-211.8	689.2
CDS	-30.1	-687.2	OP1O	-570	-435.6
MODE	570	-435.6	OP2P	-570	-268.6
V <sub>cc</sub>	-197.1	-687.2	OP2N	-570	-101.6
V <sub>cc</sub>	136.9	-687.2	OP2O	-570	65.4

Note: Substrate is connected to GND

Pad Location of PT8A2621DE

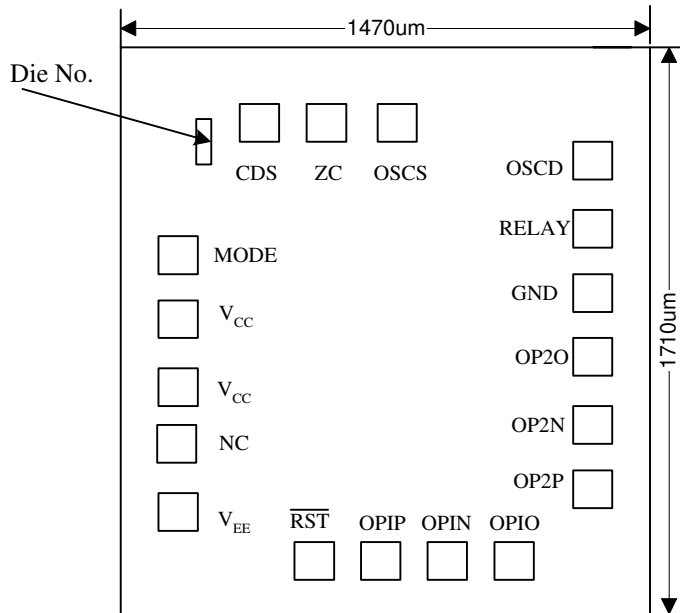

Pad Coordinate					
Pad Name	X Coordinate	Y Coordinate	Pad Name	X Coordinate	Y Coordinate
GND	570	65.4	NC	570	-268.6
RELAY	570	-101.6	V <sub>EE</sub>	-570	232.4
OSCD	570	399.4	RST	303.9	-687.2
OSCS	570	232.4	OP1P	-44.8	689.2
ZC	-378.8	689.2	OP1N	-211.8	689.2
CDS	-30.1	-687.2	OP1O	-570	-435.6
MODE	570	-435.6	OP2P	-570	-268.6
V <sub>cc</sub>	-197.1	-687.2	OP2N	-570	-101.6
V <sub>cc</sub>	136.9	-687.2	OP2O	-570	65.4

Note: Substrate is connected to GND

## Pin Assignment

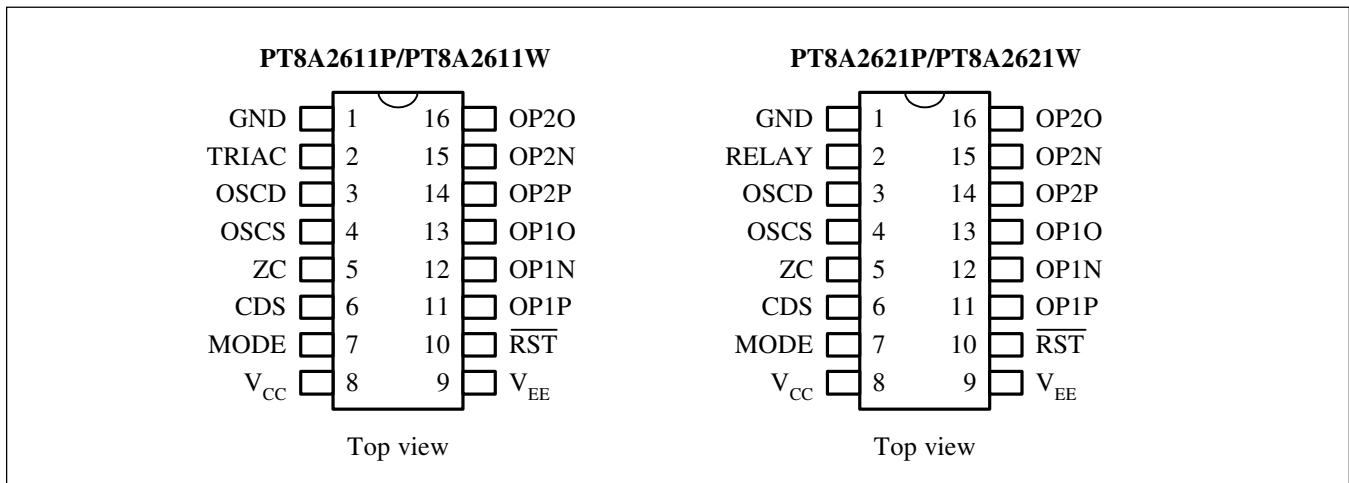

## Pin Description

Pin		Name	Type	Description
2611	2621			
1	1	GND	Ground	Ground
	2	RELAY	O	RELAY drive output through an external NPN transistor, active high
2		TRIAC	O	TRIAC drive two-pulse output, active negative pulse.
3	3	OSCD	I/O	Output timing oscillator I/O, connected to an external RC to adjust output duration.
4	4	OSCS	I/O	System oscillator I/O, connected to an external RC to set the system frequency. The system frequency = 16kHz for normal application.
5	5	ZC	I	Schmitt input for AC zero crossing detection.
6	6	CDS	I	Connected to a CDS voltage divider for daytime/night auto-detection. Low input to this pin can disable PIR input. CDS is a schmitt trigger input with 5-second input debounce time.
7	7	MODE	I	Mode select, connecting to $V_{CC}$ - output always on, connection GND - output always off, open - auto detection
8	8	$V_{CC}$	Power	Power supply
9	9	$V_{EE}$	O	Internal voltage regulator output, 3.6V with respect to ground. Connected to the drain of PIR sensor
10	10	$\overline{RST}$	I	Chip reset input, active low, kept floating or connected an RC network
11	11	OP1P	I	Non-inverted input of first operational amplifier, connected directly to source of PIR sensor
12	12	OP1N	I	Inverted input of first operational amplifier
13	13	OP1O	O	Output of first operational amplifier
14	14	OP2P	I	Non-inverted input of second operational amplifier.
15	15	OP2N	I	Inverted input of second operational amplifier
16	16	OP2O	O	Output of second operational amplifier

## Functional Descriptions

The PT8A2611 and PT8A2621 are CMOS LSI chips designed for automatic PIR lamp control. They can operate in 2-wire configuration for triac applications or in 3-wire configuration for relay applications.

The PIR sensor detects infrared power variations caused by motion of a human body and transfer to a voltage variation. If the PIR output voltage variation conforms to criteria, the lamp is turned on for an adjustable duration. The PT8A2611 (or 2621) offers three operating modes (ON, AUTO, OFF) which can be set through a MODE pin. When the device is working in AUTO mode, the user can override the mode to switch it to TEST mode or manual ON mode, or return to the AUTO mode by switching power switch.

## OSCS and OSCD Pins

OSCS is a system oscillator I/O pin connected to an external RC to generate system frequency of 16kHz. OSCD is an output timing oscillator I/O pin. It's connected to an external RC to obtain the desired turn-on duration by selecting various values of RC or using a variable resistor.  $F_{OSCD}$  is the frequency of OSCD pin, output timing can be calculated as the formula:

$$T_D = 21504/F_{OSCD}$$

## CDS Input Circuit

CDS is a CMOS schmitt trigger input pin. It is used to distinguish between day time and night time. When the input voltage of CDS is high the PIR input is enabled, when CDS low the PIR input disabled. The input disable-to-enable debounce time is 5 seconds. Connect this pin to  $V_{CC}$  when not using it. The CDS input is ignored by PT8A2611 when the TRIAC output is active, however, PT8A2621's CDS can not be ignored anytime.

Figure 1. System Oscillator

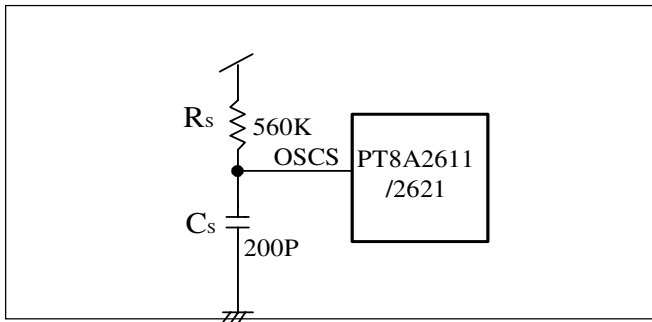

Figure 2. Output Timing Oscillator

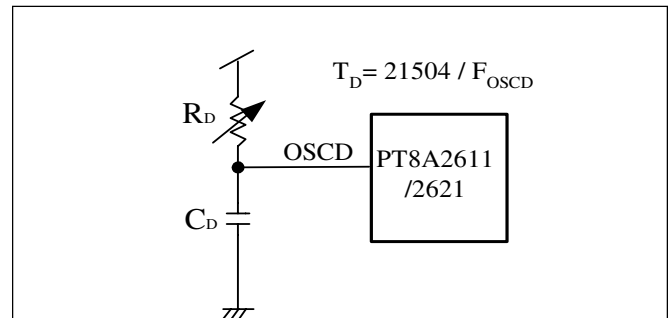

Figure 3. CDS Input Circuit

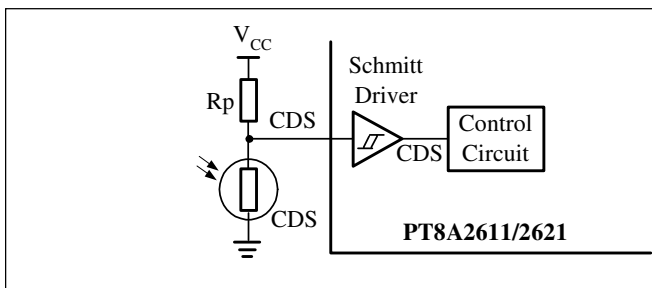

Figure 4. CDS Enable Debounce

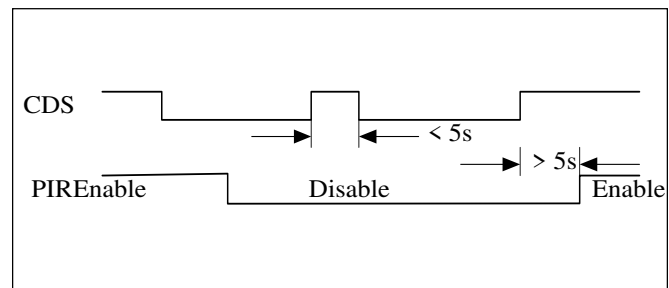

Table 1. CDS Pin Function

CDS	Status	PIR
LOW	Day Time	Disabled
HIGH	Night	Enabled

## MODE

MODE is a tri-state input pin for operation mode selection. See the following table 2.

**Override Control (for PT8A2621 only):** The term *override* refers to the change of operating mode by switching the power switch twice within 3 seconds. When the chip is working in the AUTO mode (MODE pin openned), the output is activated by a valid PIR trigger signal and the output active duration is controlled by the OSCD oscillation period. The lamp can be switched to ON from the AUTO mode by either switching the MODE pin to  $V_{CC}$  or switching the power switch twice within 3 seconds.

The device can be toggled from ON to AUTO by switching the power switch twice within 3 seconds again (override operation).

If the chip is overridden to ON and there is no further override operation, it will return to AUTO automatically after an internal preset ON time duration (8 hours).

Note:Flash is only for the TRIAC Rev.

## $\overline{RST}$ Pin

$\overline{RST}$  is used to reset the device. It is internal pull-high and active low. The use of  $C_{RST}$  can extend the power-on initial time. If the  $\overline{RST}$  pin is openned (without  $CRST$ ), the initial time is 40 seconds. See Figure 6.

**Table 2. Operation Modes by MODE Pin**

MODE Status	Operation Mode	Description
$V_{CC}$	ON	Output is always ON: RELAY pin sends high level for relay driving; TRIAC pulse train output is synchronized by ZC for triac driving.
GND	OFF	Output is always OFF: RELAY pin sends low level for relay driving; TRIAC pin sends high level for triac driving.
Open	AUTO	Outputs remain in the OFF state until activated by a valid PIR trigger input signal. When working in the AUTO mode, the device allows override control by switching the ZC signal.

**Figure 5. Override Timing (for PT8A2621)**

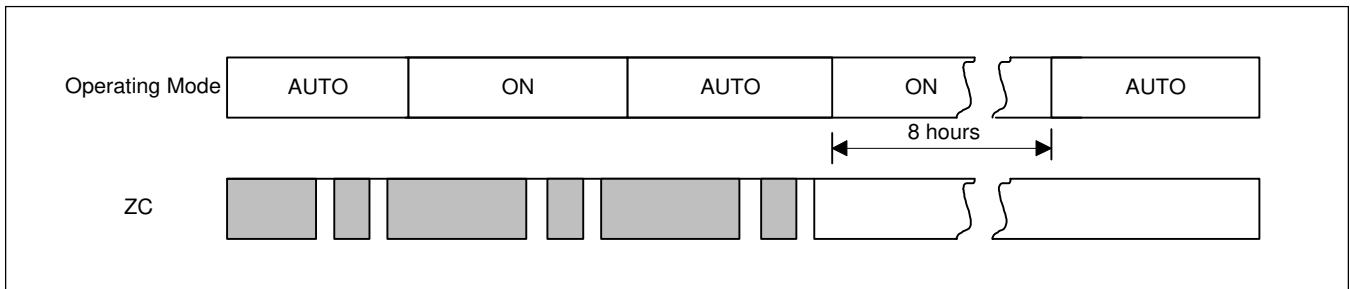

**Figure 6.  $\overline{RST}$  Application Example**

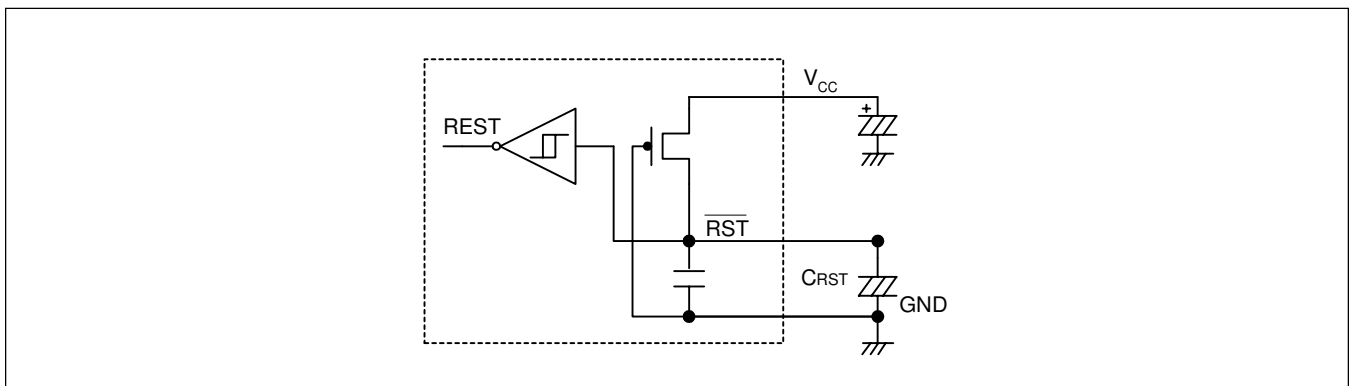

### Power On Initial

The PIR signal amplifier requires a warm up period after power-on. The input should be disabled during this period.

In the AUTO mode within the first 40 seconds of the initial time the chip allows override control to enter the quickly install mode, After 40s of the initial time the chip allows override control between ON and AUTO. It will remain in the warm up period if the total initial time has not elapsed after returning to AUTO.

In case that the ZC signal disappears more than 3 seconds, the chip will restart the initialization operation. However, the re-start initial time is always 40 seconds and cannot be extended by adding  $C_{RST}$  to the  $\overline{RST}$  pin as shown in Figure 4.

### Trigger

The trigger timing is shown in Figure 7.

Retrigger -- If another signal is attained in trigger hold time, the circuit will be retriggered, and the trigger hold time will be started from this time.

Figure 7. Trigger Timing

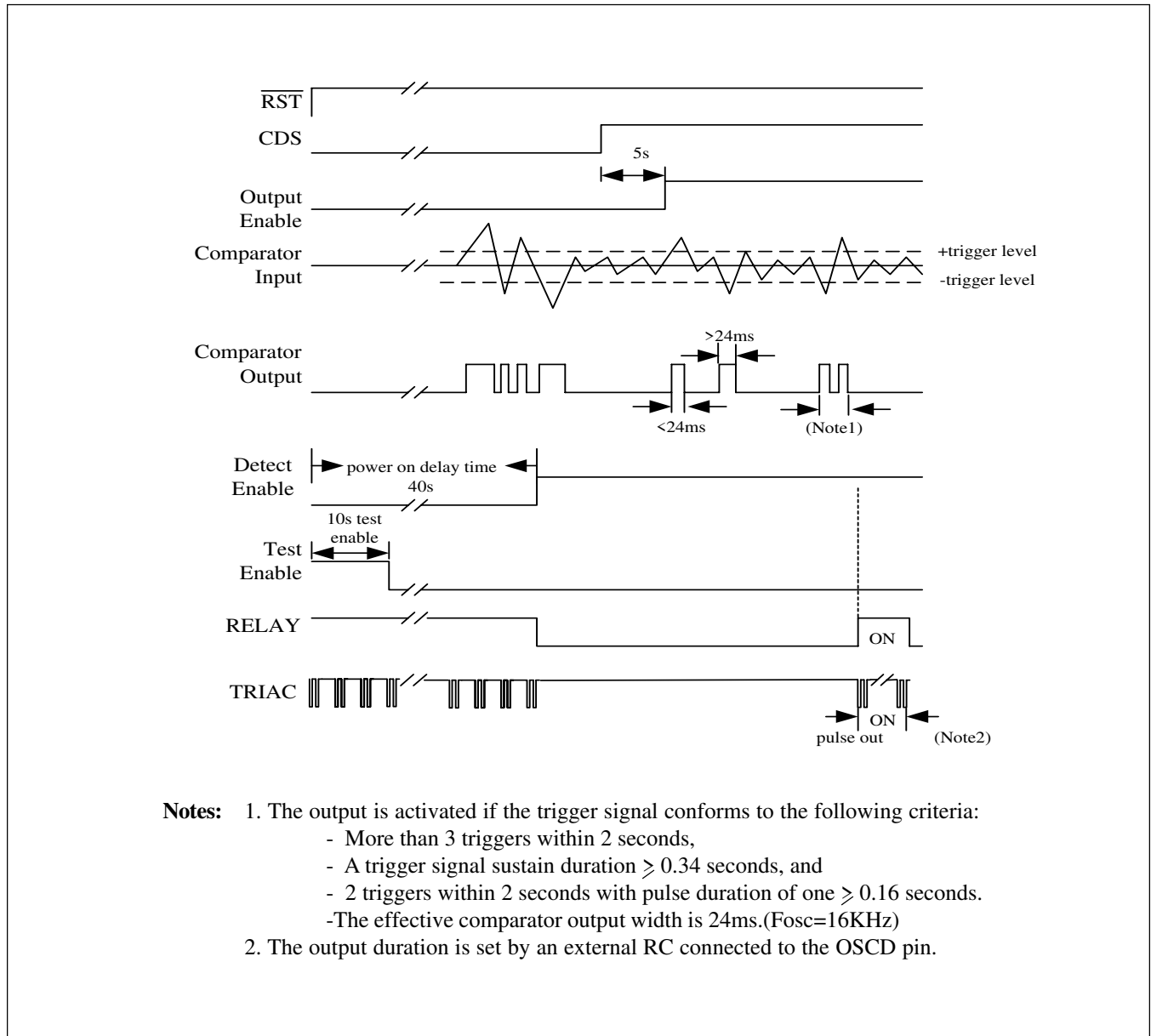

## Maximum Ratings

(Above which the useful life may be impaired. For user guidelines, not tested)

Storage Temperature .....	-40°C to +125°C
Supply Voltage to Ground Potential (Inputs & V <sub>CC</sub> Only) ....	-0.3 to +6.0V
Supply Voltage to Ground Potential (Outputs & D/O Only) .....	-0.3 to +6.0V
DC Input Voltage .....	-0.3 to +6.0V
DC Output Current .....	20mA
Power Dissipation .....	500mW

**Note:**

Stresses greater than those listed under MAXIMUM RATINGS may cause permanent damage to the device. This is a stress rating only and functional operation of the device at these or any other conditions above those indicated in the operational sections of this specification is not implied. Exposure to absolute maximum rating conditions for extended periods may affect reliability.

## Recommended Operation Conditions

Sym	Description	Min	Typ	Max	Units
V <sub>CC</sub>	Supply Voltage	4.75	5.0	6.0	V
V <sub>IH</sub>	Input HIGH Voltage(MODE, $\overline{RST}$ )	0.8V <sub>CC</sub>	-	-	V
V <sub>IL</sub>	Input LOW Voltage(MODE, $\overline{RST}$ )	-	-	0.2V <sub>CC</sub>	V
f <sub>SYS</sub>	System Oscillator Frequency	12.8	16	20.8	kHz
f <sub>DOSC</sub>	Delay Oscillator Frequency	12.8	16	19.2	kHz
T <sub>A</sub>	Operation Temperature	-25	25	70	°C

## DC Electrical Characteristics

Sym	Description	Test Conditions	Min	Typ	Max	Units
I <sub>IH</sub>	Input high level leakage current(ZC,CDS)	V <sub>IH</sub> = 4.5V	-0.1	-	0.1	μA
I <sub>IL</sub>	Input low level leakage current(ZC,CDS)	V <sub>IL</sub> = 0.5V	-0.1	-	0.1	μA
I <sub>OH</sub>	Output Source Current (RELAY, TRIAC)	V <sub>OH</sub> = 4.5V	-6	-	-	mA
I <sub>OL</sub>	Output Sink Current (RELAY, TRIAC)	V <sub>OL</sub> = 0.5V	15	-	-	mA
V <sub>TH1</sub>	CDS Transfer High Voltage		3.0	3.2	3.6	V
V <sub>TL1</sub>	CDS Transfer Low Voltage		1.5	1.7	2.1	V
V <sub>TH2</sub>	ZC Transfer High Voltage		2.6	2.9	3.2	V
V <sub>TL2</sub>	ZC Transfer Low Voltage		1.0	1.4	1.6	V
V <sub>TH3</sub>	OSCS Transfer High Voltage		2.2	2.4	2.8	V
V <sub>TL3</sub>	OSCS Transfer Low Voltage		1.0	1.4	1.6	V
V <sub>TH4</sub>	OSCD Transfer High Voltage		2.2	2.4	2.8	V
V <sub>TL4</sub>	OSCD Transfer Low Voltage		0.4	0.6	0.8	(ZC,)V

**Note:** These specifications apply for V<sub>CC</sub> = 5.0V and -25°C ≤ T<sub>A</sub> ≤ 70°C, unless otherwise specified.



## AC Electrical Characteristics

### Voltage Regulator

Sym	Description	Test Conditions	Min	Typ	Max	Units
$V_{EE}$	Output Voltage	No load	3.2	3.6	4.0	V
$V_{OP2P}$	Noninverting input of OP2	No load	1.6	1.8	2.0	V
$\Delta V_O$	Line Regulation	$4.5V \leq V_{CC} \leq 5.5V, I_L = 1mA$	-	30	50	mV
$\Delta V_{LDR}$	Load Regulation	$V_{CC} = 5V, 0.5mA \leq I_L \leq 2mA$	-	60	100	mV
$I_L$	Regulator Output Current	$V_{CC} = 5V$	4	-	-	mA

### Operational Amplifier and Window Comparator

Sym	Description	Test Conditions	Min	Typ	Max	Units
BW	3dB Bandwidth	-	10	-	-	kHz
$V_{TH}$	Windows Comparator Threshold	$V_{CC} = 5V$	1.9	2.05	2.2	V
$V_{TL}$		$V_{CC} = 5V$	1.4	1.55	1.7	V

### Oscillator and ZC Input Pulse and Trigger Output Pulse

Sym	Description	Test Conditions	Min	Typ	Max	Units
$f_{OSC}$	Oscillator Frequency	$V_{CC} = 5V, R_S = 560\Omega,$ $C_S = 200pF,$ see above fig1	12.8	16	20.8	kHz
$t_{ZR}$	ZC Pulse Rise Time		-	30	100	ns
$t_{ZF}$	ZC Pulse Fall Time		-	30	100	ns
$t_{ZP}$	ZC Pulse Period		15.1	20	22.2	ms
$t_{ZW}$	ZC Pulse Width		0.8	1	-	ms
$t_{OR}$	TRIAC Pulse Rise Time		-	30	100	ns
$t_{OF}$	TRIAC Pulse Fall Time		-	30	100	ns
$t_{OP}$	TRIAC Pulse Period		6.6	10	11	ms
$t_{OW}$	TRIAC Pulse Width		48	62.5	76	$\mu s$

Figure 8. Timing Diagram

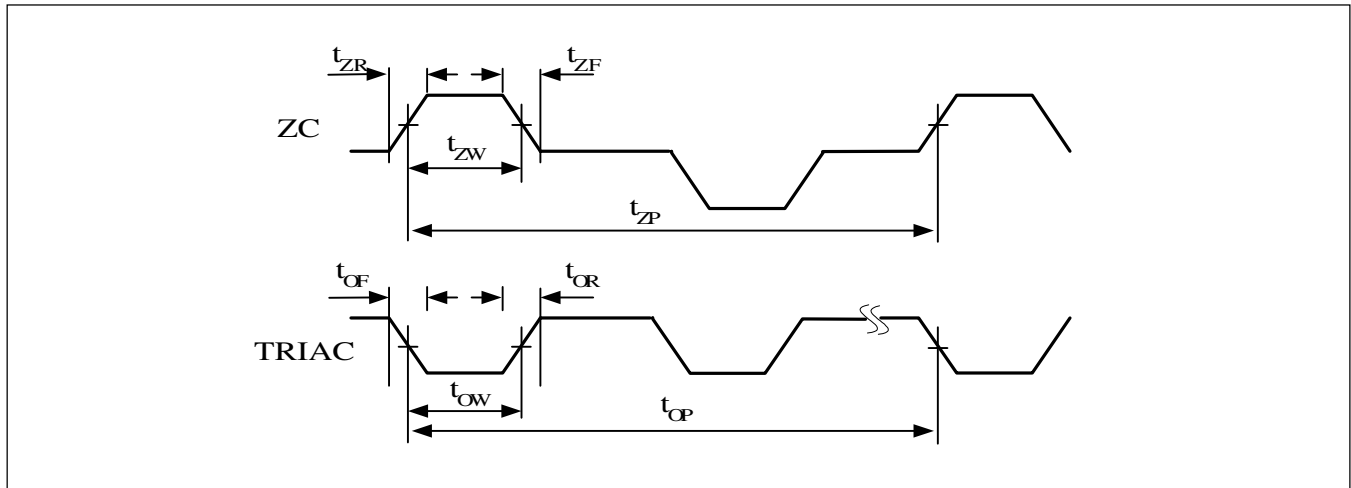

### Power Dissipation

Sym	Description	Test Conditions	Min	Typ	Max	Units
$I_{CC}$	Power Supply Current	$V_{CC} = 5V, R_S = 560k\Omega, C_S = 200P,$ $R_D = 560k\Omega, C_D = 200P,$ other input pins = GND, all outputs float. see fig1,2	-	80	100	$\mu A$
$I_{CCQ}$	Quiescent Power Supply Current	$V_{CC} = 5V,$ All Input Pins = GND, all outputs float.	-	60	80	$\mu A$

### Typical Application Circuits

Figure 9. Two-Wire Application Circuit of PT8A2611

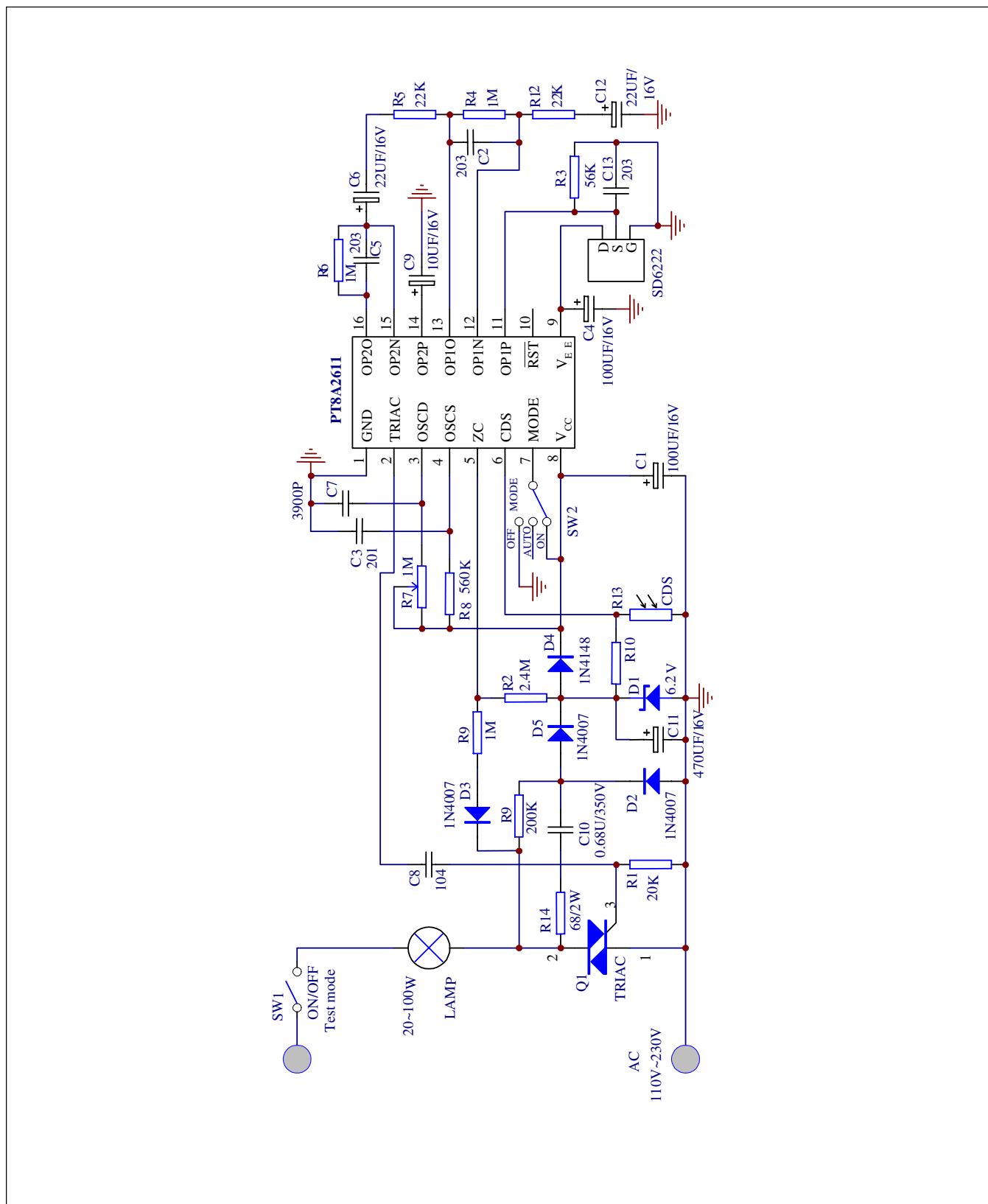
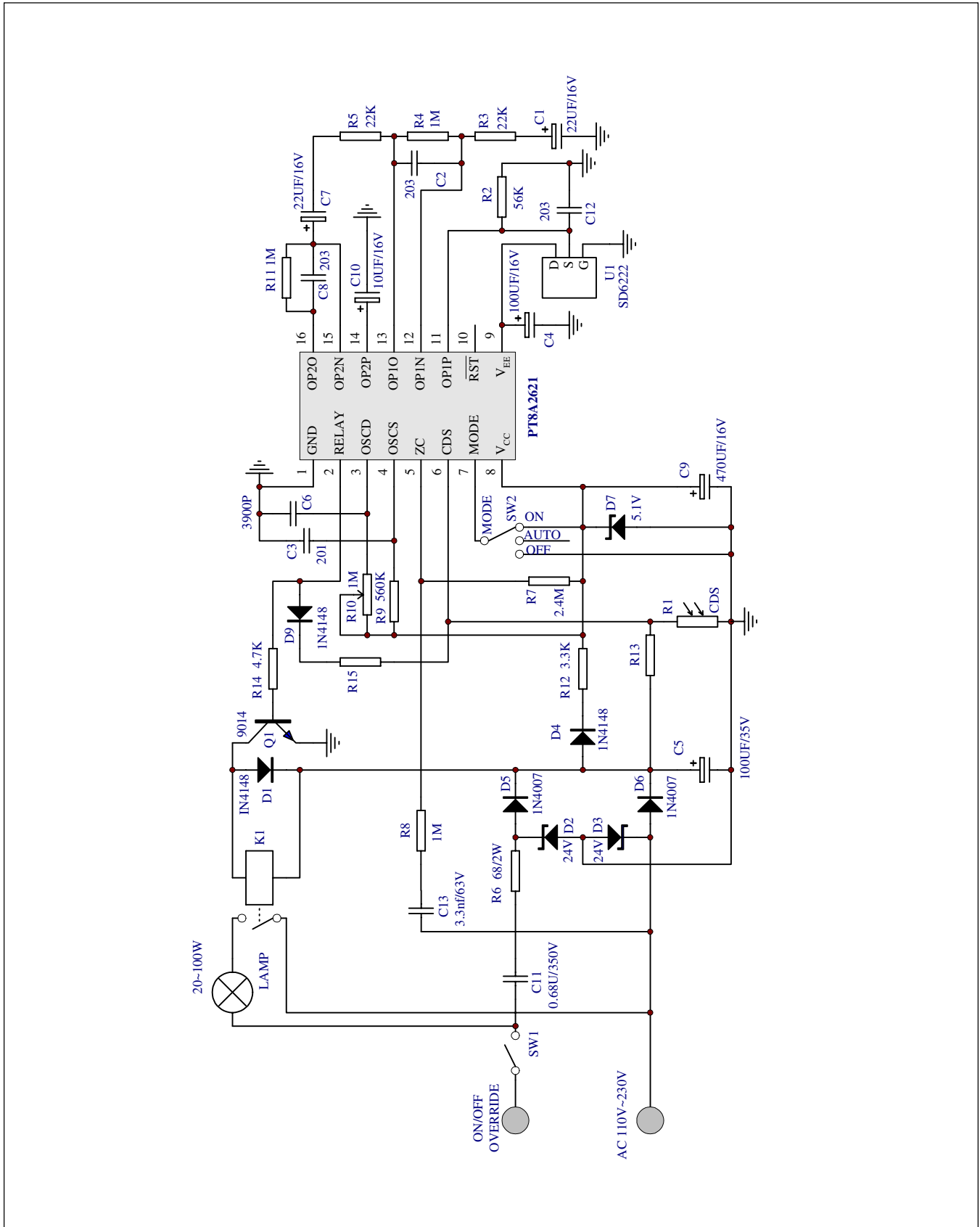
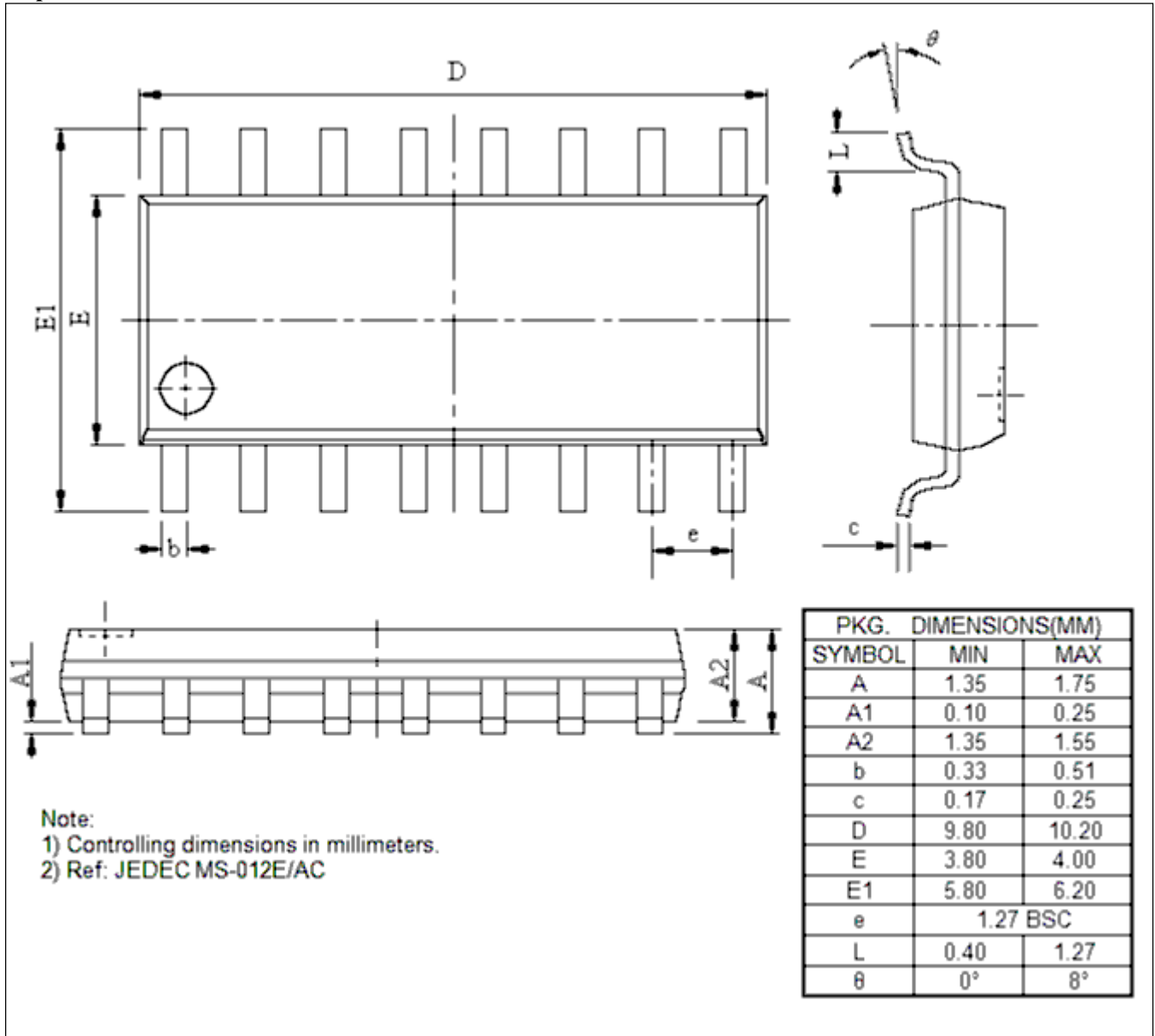

Figure 10. Three-Wire Application Circuit of PT8A2621



**Mechanical Information**

16-pin SOIC



16-pin DIP

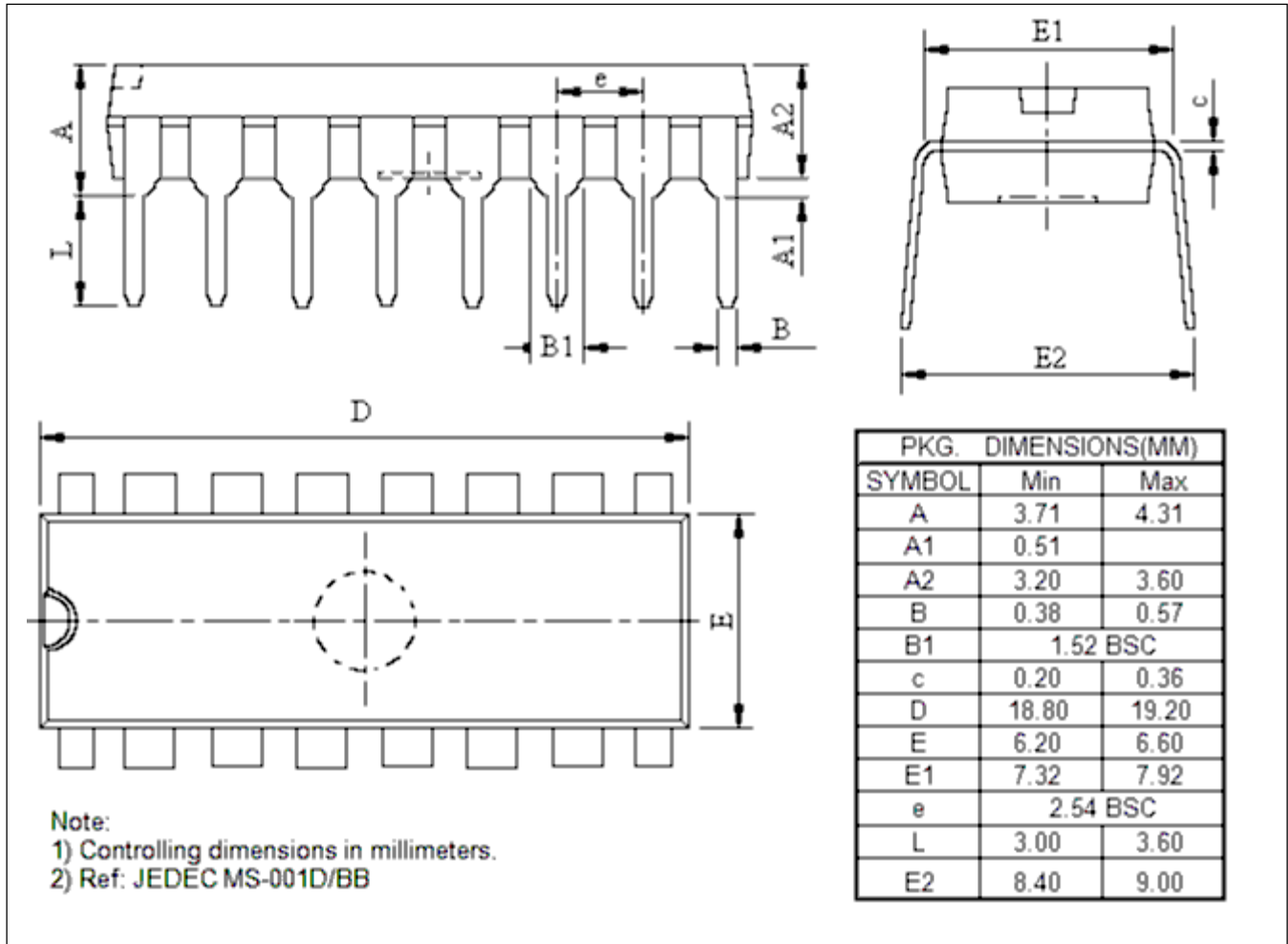

Pericom Semiconductor Corporation • 1-800-435-2336 • www.pericom.com

Pericom Technology Incorporation reserves the right to make changes to its products or specifications at any time, without notice, in order to improve design or performance and to supply the best possible product. Pericom Technology does not assume any responsibility for use of any circuitry described other than the circuitry embodied in Pericom Technology product. The company makes no representations that circuitry described herein is free from patent infringement or other rights, of Pericom.