

NM93C56

2K-Bit Serial CMOS EEPROM (MICROWIRE™ Bus Interface)

General Description

The NM93C56 devices are 2048 bits of CMOS non-volatile electrically erasable memory divided into 128 16-bit registers. They are fabricated using Fairchild Semiconductor's floating-gate CMOS process for high reliability, high endurance and low power consumption. These memory devices are available in an 8-pin SOIC or 8-pin TSSOP package for small space considerations.

The serial interface that operates this EEPROM is MICROWIRE compatible for simple interface to standard microcontrollers and microprocessors. There are 7 instructions which control this device: Read, Write Enable, Erase, Erase All, Write, Write All, and Write Disable. The ready/busy status is available on the DO pin to indicate the completion of a programming cycle.

Features

- Device status during programming mode
- Typical active current of 200µA
10µA standby current typical
1µA standby current typical (L)
0.1µA standby current typical (LZ)
- No erase required before write
- Reliable CMOS floating gate technology
- 2.7V to 5.5V operation in all modes
- MICROWIRE compatible serial I/O
- Self-timed programming cycle
- 40 years data retention
- Endurance: 1,000,000 data changes
- Packages available: 8-pin SO, 8-pin DIP, 8-pin TSSOP

Block Diagram

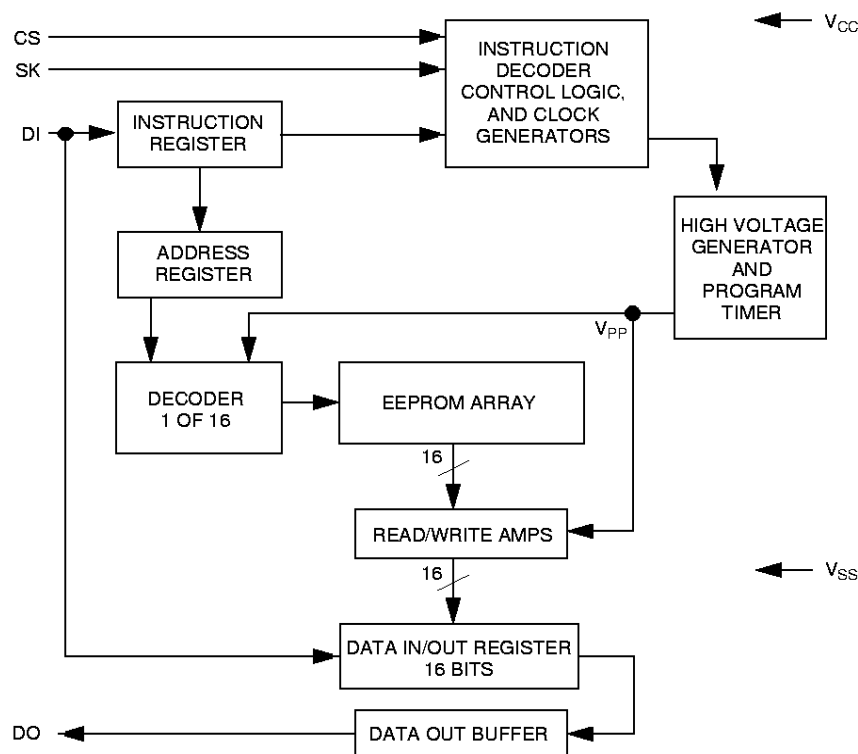

DS500081-1

Connection Diagrams

**Dual-In-Line Package (N),
8-Pin SO (M8) and 8-Pin TSSOP (MT8)**

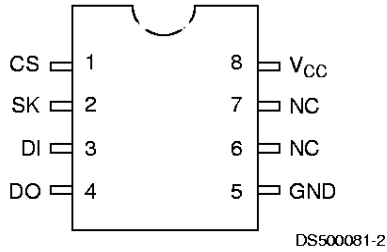

Rotated Die (93C56T)

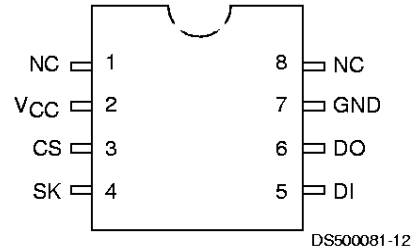

Top View
See Package Number
N08E, M08A and MTC08

Pin Names

CS	Chip Select
SK	Serial Data Clock
DI	Serial Data Input
DO	Serial Data Output
GND	Ground
V _{CC}	Power Supply

Ordering Information

Letter	Description
NM	Interface
93	Interface
C	Density
XX	Density
I	Density
LZ	Voltage Operating Range
E	Temp. Range
XX	Temp. Range
Package	Package
N	8-Pin DIP
M8	8-Pin SO8
MT8	8-Pin TSSOP
None	0 to 70°C
V	-40 to +125°C
E	-40 to +85°C
Blank	4.5V to 5.5V
L	2.7V to 4.5V
LZ	2.7V to 4.5V and <1μA Standby Current
Blank	Normal Pin Out
T	Rotated Die Pin Out
56	2K
C	CMOS
CS	Data protect and sequential read
93	MICROWIRE
NM	Fairchild Non-Volatile Memory

Absolute Maximum Ratings (Note 1)

Ambient Storage Temperature	-65°C to +150°C
All Input or Output Voltage with Respect to Ground	+6.5V to -0.3V
Lead Temperature (Soldering, 10 sec.)	+300°C
ESD Rating	2000V

Operating Range

Ambient Operating Temperature	NM93C56	0°C to +70°C
	NM93C56E	-40°C to +85°C
	NM93C56V	-40°C to +125°C
Power Supply (V_{CC})		4.5V to 5.5V

Standard V_{CC} (4.5V to 5.5V) DC and AC Electrical Characteristics

Symbol	Parameter	Part Number	Conditions	Min.	Max.	Units
I_{CCA}	Operating Current		CS = V_{IH} , SK = 1MHz		1	mA
I_{CCS}	Standby Current		CS = V_{IL}		50	μ A
I_{IL} I_{OL}	Input Leakage Output Leakage		$V_{IN} = 0V$ to V_{CC} (Note 2)		± 1	μ A
V_{IL} V_{IH}	Input Low Voltage Input High Voltage			-0.1 2	0.8 $V_{CC} + 1$	V
V_{OL1} V_{OH1}	Output Low Voltage Output High Voltage		$I_{OL} = 2.1mA$ $I_{OH} = -400 \mu A$	2.4	0.4	V V
V_{OL2} V_{OH2}	Output Low Voltage Output High Voltage		$I_{OL} = 10 \mu A$ $I_{OH} = -10 \mu A$	$V_{CC} - 0.2$	0.2	V V
f_{SK}	SK Clock Frequency		(Note 3)	0	1	MHz
t_{SKH}	SK High Time	NM93C56 NM93C56E/V		250 300		ns
t_{SKL}	SK Low Time			250		ns
t_{SKS}	SK Setup Time		SK must be at V_{IL} for t_{SKS} before CS goes high	50		ns
t_{CS}	Minimum CS Low Time		(Note 4)	250		ns
t_{CSS}	CS Setup Time			50		ns
t_{DH}	DO Hold Time			70		ns
t_{DIS}	DI Setup Time	NM93C56 NM93C56E/V		100 200		ns
t_{CSH}	CS Hold Time			0		ns
t_{DIH}	DI Hold Time			20		ns
t_{PD1}	Output Delay to "1"				500	ns
t_{PD0}	Output Delay to "0"				500	ns
t_{SV}	CS to Status Valid				500	ns
t_{DF}	CS to DO in TRI-STATE		CS = V_{IL}		100	ns
t_{WP}	Write Cycle Time				10	ms

Absolute Maximum Ratings (Note 1)

Ambient Storage Temperature	-65°C to +150°C
All Input or Output Voltage with Respect to Ground	+6.5V to -0.3V
Lead Temperature (Soldering, 10 sec.)	+300°C
ESD Rating	2000V

Operating Range

Ambient Operating Temperature	0°C to +70°C
NM93C56L/LZ	-40°C to +85°C
NM93C56LE/LZE	-40°C to +125°C
NM93C56LV/LZV	
Power Supply (V _{CC})	2.7V to 4.5V

Low V_{CC} (2.7V to 4.5V) DC and AC Electrical Characteristics

Symbol	Parameter	Part Number	Conditions	Min.	Max.	Units
I _{CCA}	Operating Current		CS = V _{IH} , SK = 250KHz		1	mA
I _{CCS}	Standby Current		CS = V _{IL}		10	μA
	L				1	μA
	LZ					
I _{IL} I _{OL}	Input Leakage Output Leakage		V _{IN} = 0V to V _{CC} (Note 2)		±1	μA
V _{IL} V _{IH}	Input Low Voltage Input High Voltage			-0.1 0.8 V _{CC}	0.15 V _{CC} V _{CC} + 1	V
V _{OL} V _{OH}	Output Low Voltage Output High Voltage		I _{OL} = 10 μA I _{OH} = -10 μA	0.9 V _{CC}	0.1 V _{CC}	V
f _{SK}	SK Clock Frequency		(Note 3)	0	250	KHz
t _{SKH}	SK High Time			1		μs
t _{SKL}	SK Low Time			1		μs
t _{SKS}	SK Setup Time		SK must be at V _{IL} for t _{SKS} before CS goes high	0.2		μs
t _{CS}	Minimum CS Low Time		(Note 4)	1		μs
t _{CSS}	CS Setup Time			0.2		μs
t _{DH}	DO Hold Time			70		ns
t _{DIS}	DI Setup Time			0.4		μs
t _{CSH}	CS Hold Time			0		ns
t _{DIH}	DI Hold Time			0.4		μs
t _{PD1}	Output Delay to "1"				2	μs
t _{PD0}	Output Delay to "0"				2	μs
t _{SV}	CS to Status Valid				1	μs
t _{DF}	CS to DO in TRI-STATE		CS = V _{IL}		0.4	μs
t _{WP}	Write Cycle Time				15	ms

Capacitance T_A = 25°C, f = 1 MHz (Note 5)

Symbol	Test	Typ	Max	Units
C _{OUT}	Output Capacitance		5	pF
C _{IN}	Input Capacitance		5	pF

Note 1 Stress above those listed under "Absolute Maximum Ratings" may cause permanent damage to the device. This is a stress rating only and functional operation of the device at these or any other conditions above those indicated in the operational sections of the specification is not implied. Exposure to absolute maximum rating conditions for extended periods may affect device reliability.

Note 2 Typical leakage values are in the 20nA range.

Note 3 The shortest allowable SK clock period = 1/f_{SK} (as shown under the f_{SK} parameter). Maximum SK clock speed (minimum SK period) is determined by the interaction of several AC parameters stated in the datasheet. Within this SK period, both t_{SKH} and t_{SKL} limits must be observed. Therefore, it is not allowable to set 1/f_{SK} = t_{SKHminimum} + t_{SKLminimum} for shorter SK cycle time operation.

Note 4 CS (Chip Select) must be brought low (to V_{IL}) for an interval of t_{CS} in order to reset all internal device registers (device reset) prior to beginning another opcode cycle. (This is shown in the opcode diagram on the following page.)

Note 5 This parameter is periodically sampled and not 100% tested.

AC Test Conditions

V _{CC} Range	V _{IL} /V _{IH} Input Levels	V _{IL} /V _{IH} Timing Level	V _{OL} /V _{OH} Timing Level	I _{OL} /I _{OH}
2.7V ≤ V _{CC} ≤ 5.5V (Extended Voltage Levels)	.03V/1.8V	1.0V	0.8V/1.5V	±10μA
4.5V ≤ V _{CC} ≤ 5.5V (TTL Levels)	0.4V/2.4V	1.0V/2.0V	0.4V/2.4V	-2.1mA/0.4mA

Output Load: 1 TTL Gate (C_L = 100 pF)

Functional Description

The NM93C56 device has 7 instructions as described below. Note that the MSB of any instruction is a "1" and is viewed as a start bit in the interface sequence. The next 10 bits carry the op code and the 8-bit address for register selection.

Read (READ):

The READ instruction outputs serial data on the D0 pin. After a READ instruction is received, the instruction and address are decoded, followed by data transfer from the selected memory register into a 16-bit serial-out shift register. A dummy bit (logical 0) precedes the 16-bit data output string. Output data changes are initiated by a low to high transition of the SK clock.

Write Enable (WEN):

When V_{CC} is applied to the part, it 'powers-up' in the Write Disable (WDS) state. Therefore, all programming modes must be preceded by a Write Enable (WEN) instruction. Once a Write Enable instruction is executed, programming remains enabled until a Write Disable (WDS) instruction is executed or V_{CC} is removed from the part.

Erase (ERASE):

The ERASE instruction will program all bits in the specified register to the logical "1" state. CS is brought low following the loading of the last address bit. This falling edge of the CS pin initiates the self-timed programming cycle.

The DO pin indicates the READY/BUSY status of the chip if CS is brought high after a minimum time of t_{CS} . DO = logical "0" indicates that the register, at the address specified in the instruction, has been erased, and the part is ready for another instruction.

Write (WRITE):

The WRITE instruction is followed by the address and 16 bits of data to be written into the specified address. After the last bit of data is put in the data-in (DI) pin, CS must be brought low before the next rising edge of the SK clock. This falling edge of the CS initiates the self-timed programming cycle. The D0 pin indicates the READY/BUSY status of the chip if CS is brought high after a minimum of t_{CS} . DO = logical 1 indicates that the register at the address specified in the instruction has been written with the data pattern specified in the instruction and the part is ready for another instruction.

Erase All (ERAL):

The ERAL instruction will simultaneously program all registers in the memory array and set each bit to the logical "1" state. The Erase All cycle is identical to the ERASE cycle except for the different op-code. As in the ERASE mode, the DO pin indicates the READY/BUSY status of the chip if CS is brought high after the t_{CS} interval.

Write All (WRALL):

The WRALL instruction will simultaneously program all registers with the data pattern specified in the instruction. As in the WRITE mode, the DO pin indicates the READY/BUSY status of the chip if CS is brought high after the t_{CS} interval.

Write Disable (WDS):

To protect against accidental data disturb, the WDS instruction disables all programming modes and should follow all programming operations. Execution of a READ instruction is independent of both the WEN and WDS instructions.

Note: The Fairchild CMOS EEPROMs do not require an "ERASE" or "ERASE ALL" operation prior to the "WRITE" and "WRITE ALL" instructions. The "ERASE" and "ERASE ALL" instructions are included to maintain compatibility with earlier technology EEPROMs.

Instruction Set for the NM93C56

Instruction	SB	Op. Code	Address	Data	Comments
READ	1	10	A7-A0		Reads data stored in memory, at specified address.
WEN	1	00	11xxxxxx		Write enable must precede all programming modes.
ERASE	1	11	A7-A0		Erase selected register.
WRITE	1	01	A7-A0	D15-D0	Writes selected register.
ERAL	1	00	10xxxxxx		Erases all registers.
WRALL	1	00	01xxxxxx	D15-D0	Writes all registers.
WDS	1	00	00xxxxxx		Disables all programming instructions.

Note: A7 is "don't care" bit, but must be included in the address string.

Timing Diagrams

Synchronous Data Timing

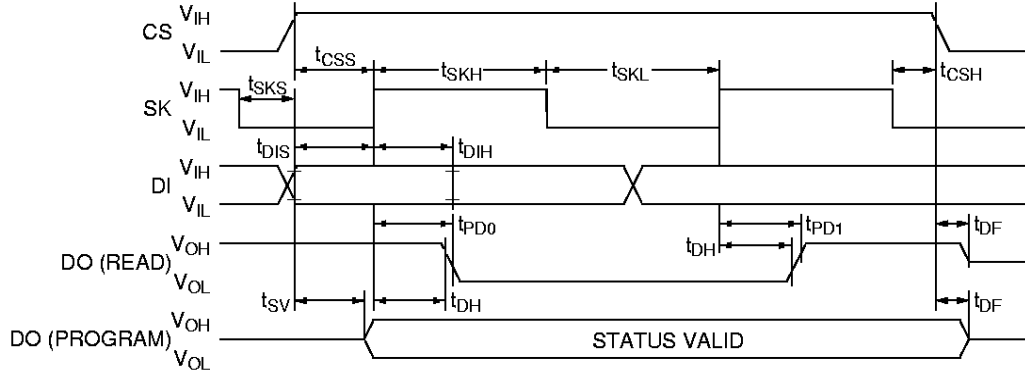

DS500081-4

READ

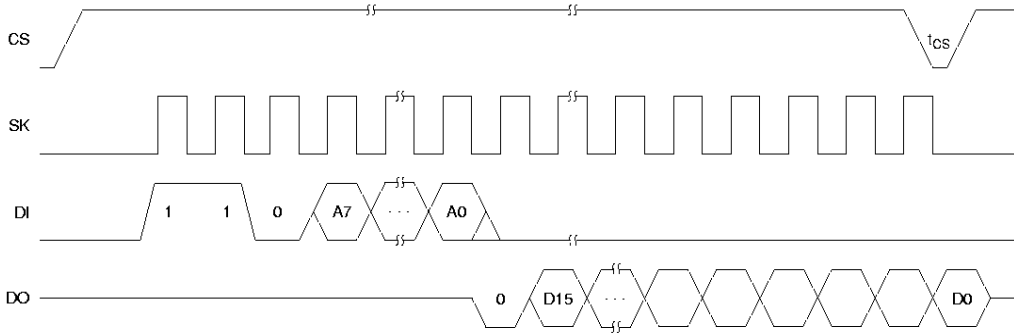

DS500081-5

WEN

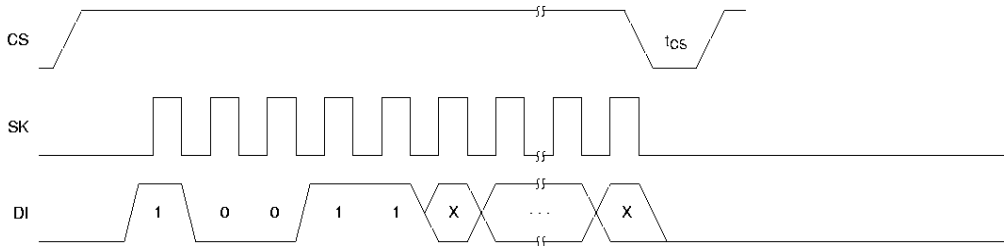

DS500081-6

WDS

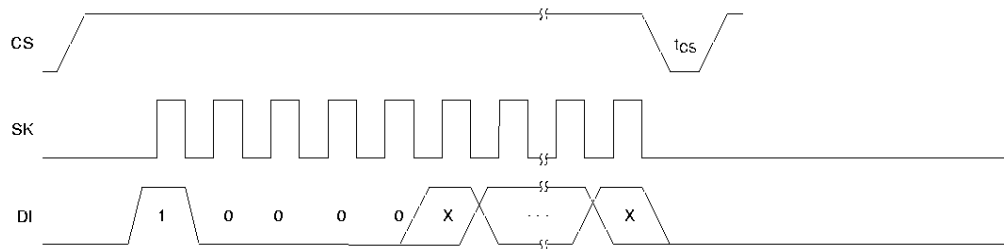

DS500081-7

Timing Diagrams (Continued)

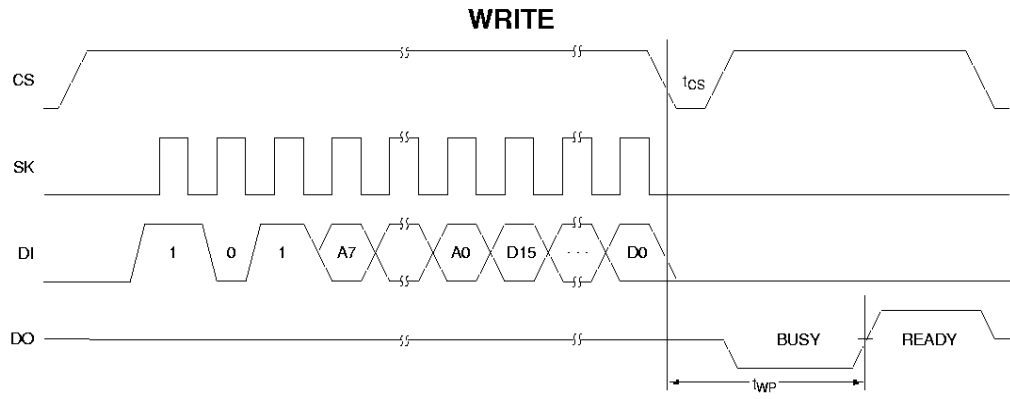

DS500081-8

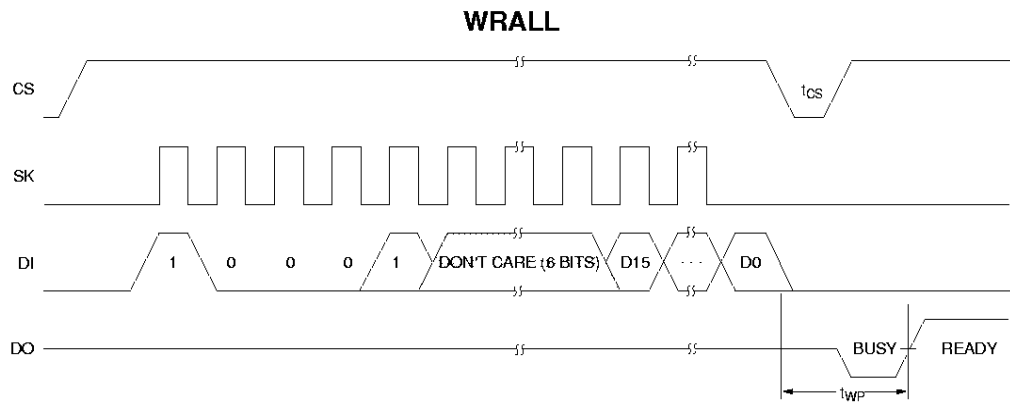

DS500081-9

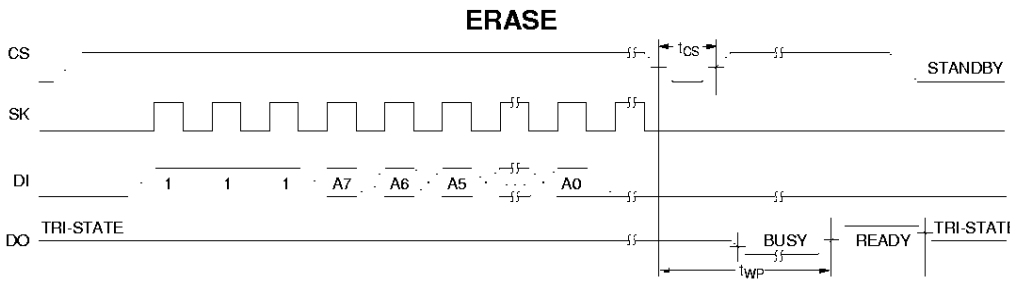

DS500081-10

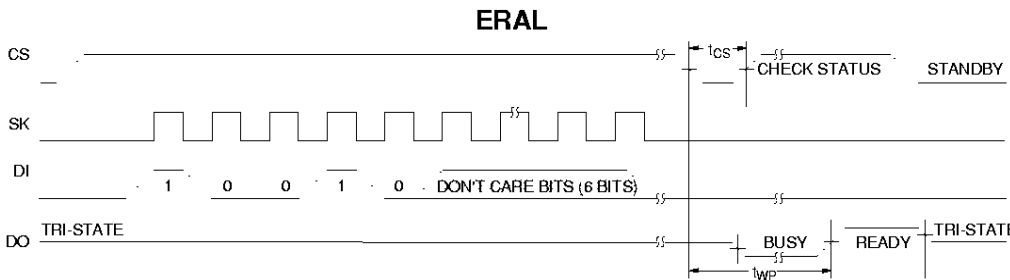

DS500081-11

Physical Dimensions inches (millimeters) unless otherwise noted

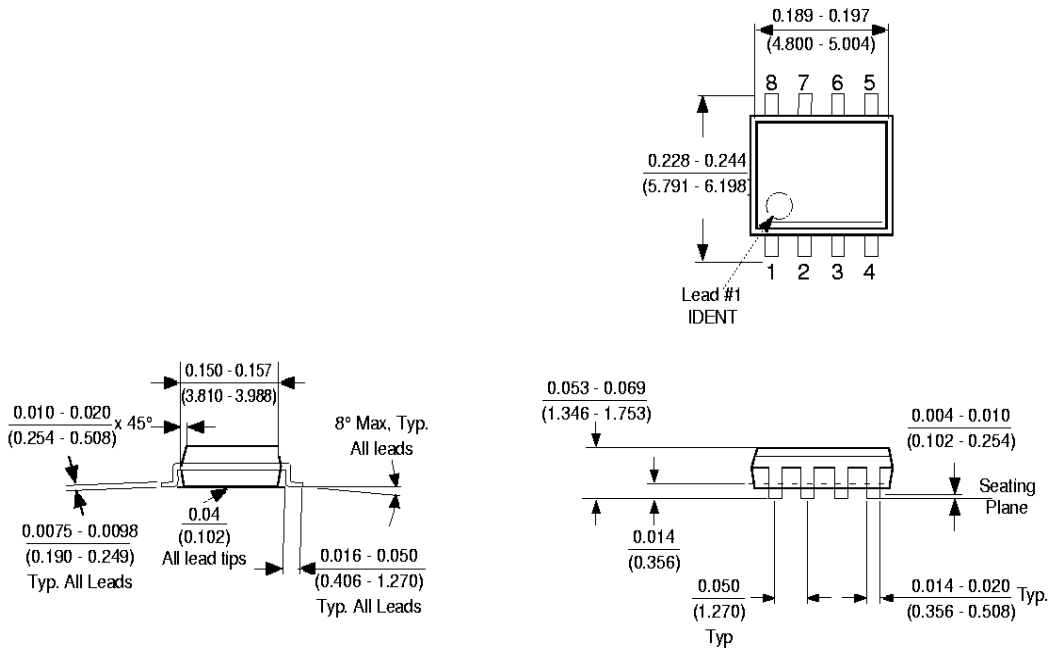

**Molded Small Out-Line Package (M8)
Package Number M08A**

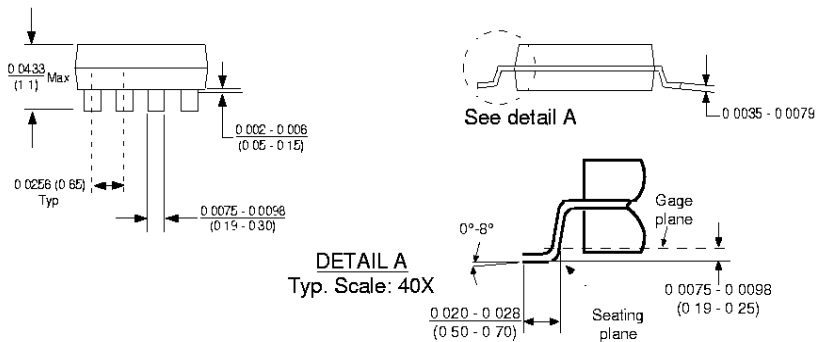
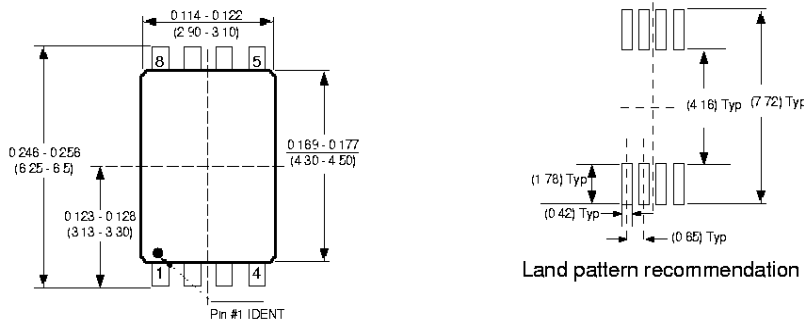

Notes: Unless otherwise specified
1. Reference JEDEC registration MO153. Variation AA. Dated 7/93

**8-Pin Molded TSSOP, JEDEC (MT8)
Package Number MTC08**

Physical Dimensions inches (millimeters) unless otherwise noted

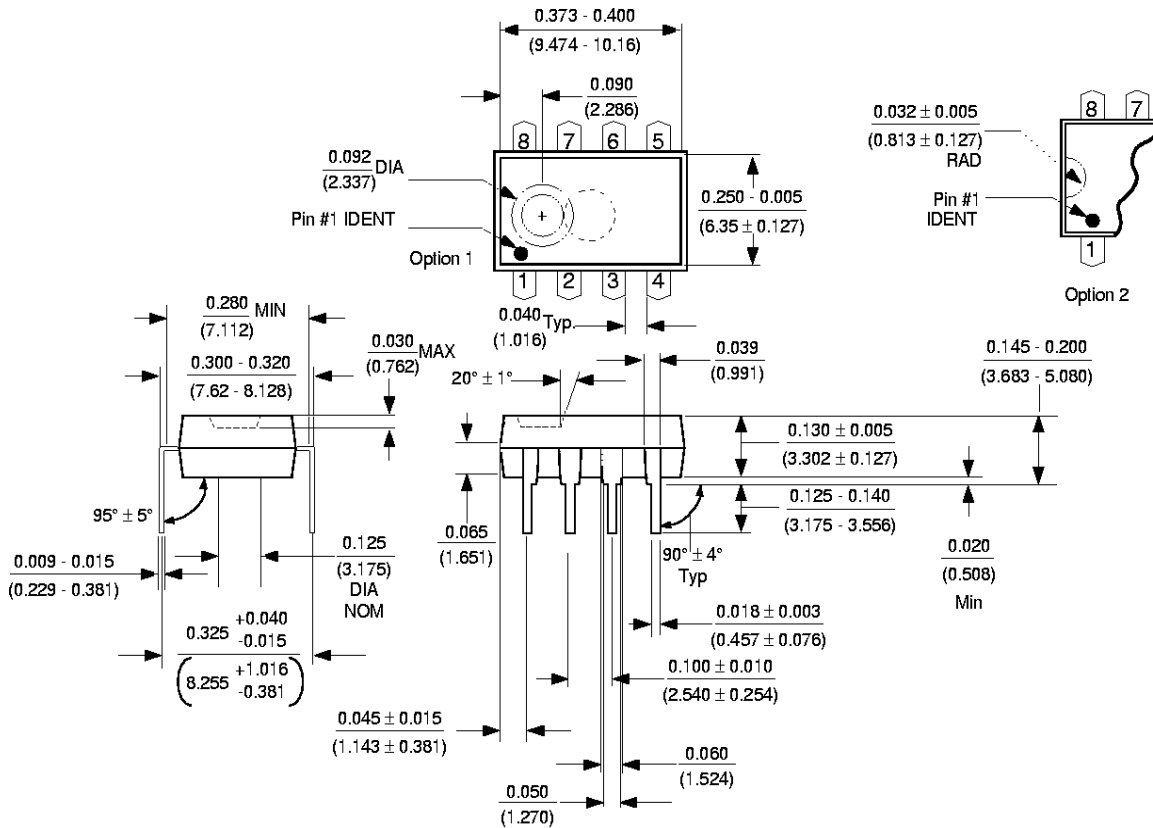

**Molded Dual-In-Line Package (N)
Package Number N08E**

Life Support Policy

Fairchild's products are not authorized for use as critical components in life support devices or systems without the express written approval of the President of Fairchild Semiconductor Corporation. As used herein:

1. Life support devices or systems are devices or systems which, (a) are intended for surgical implant into the body, or (b) support or sustain life, and whose failure to perform, when properly used in accordance with instructions for use provided in the labeling, can be reasonably expected to result in a significant injury to the user.
2. A critical component is any component of a life support device or system whose failure to perform can be reasonably expected to cause the failure of the life support device or system, or to affect its safety or effectiveness.

**Fairchild Semiconductor
Americas
Customer Response Center**
Tel 1-888-522-5372

**Fairchild Semiconductor
Europe**

Fax +44 (0) 1793-856856
Tel +49 (0) 8141-6102-0
English Tel +44 (0) 1793-856856
Français Tel +33 (0) 1-6930-3696
Italiano Tel +39 (0) 2-249111-1

**Fairchild Semiconductor
Hong Kong**

8/F, Room 808, Empire Centre
68 Mody Road, Tsimshatsui East
Kowloon Hong Kong
Tel, +852-2722-8338
Fax +852-2722-8383

**Fairchild Semiconductor
Japan Ltd.**

4F, Natsume Bldg
2-18-6, Yushima, Bunkyo-ku
Tokyo, 113-0034 Japan
Tel 81-3-3818-8640
Fax 81-3-3818-8641

Fairchild does not assume any responsibility for use of any circuitry described, no circuit patent licenses are implied and Fairchild reserves the right at any time without notice to change said circuitry and specifications.