



PSE Technology Corporation

SPECIFICATION FOR APPROVAL

CUSTOMER	
NOMINAL FREQUENCY	32.768 KHz
HOLDER TYPE	TYPE G3 Cylinder SMD Quartz Crystal
SPEC. NO. (P/N)	G33270007
CUSTOMER P/N	
ISSUE DATE	Apr.25,2011
VERSION	D

APPROVED	PREPARED	QA
<i>Brenda</i>	<i>Clair</i>	<i>Isatku</i>
APPROVED BY CUSTOMER :		AVL Status
Please return one copy with approval to PSE-TW		

PSE Technology Corporation

No.2, Tzu-Chiang 5th Rd, Chung Li Industrial Park,
 Chung Li City, Taoyuan County, Taiwan (R.O.C.)
 TEL: 886-3-451-8888
 FAX: 886-3-461-3865
<http://www.saronix-ecera.com.tw>

- *RoHS Exception
- *HF-Halogen Free
- *REACH Compliant

*** A company of **PERICOM Semiconductor Corporation** ***

TYPE G3 Cylinder SMD Quartz Crystal

G33270007

VER. D 25-Apr-11

VERSION HISTORY

Version No.	Version Date	Customer Receipt Date	Supplier Receipt Date	Description	Notes
A	Mar.12,2010			Initial Release	
B	Jul.23,2010			Changed Pb- Free to RoHS Compliant by Exemption	
C	Aug.26,2010			Correct Marking from 32.768 to 32768	
D	Apr.25,2011			Revised format	

TYPE G3 Cylinder SMD Quartz Crystal

G33270007

VER. D 25-Apr-11

ELECTRICAL SPECIFICATIONS

SRe Part Number : G33270007

Parameters	Symbol	Specifications	Units	Notes
Nominal Frequency	Fn	32.768	KHz	
Mode of Oscillation	MO	Fundamental		+2° X-Cut
Load Capacitance	CL	12.5	pF	Typical
Calibration Tolerance		± 20	ppm	at 25°C ± 5°C
Operating Temperature Range	TR	-40~85	°C	
Drive Level	DL	1	μW	Max.
Series Resonant Resistance	CI/RR	50	KΩ	Max.
Temperature Coefficient	K	-0.035	ppm/°C ²	Typical
Aging		± 3	ppm	Max 1st year
Insulation Resistance		500	MΩ	at DC 100V ± 15V

Reliability (Mechanical and Environmental Endurance)

No.	Test Items	Test Method and Condition	Requirements
1	Vibration	(1) Vibration Frequency: 10 to 55Hz (2) Vibration Amplitude: 1.5mm (3) Cycle Time: 1-2min(10-55-10Hz) (4) Direction: X.Y.Z (5) Duration: 2h/each direction	Frequency Change: ±10ppm Max. Resistance Change: ±15% or 5kΩ Max.
2	Shock	3 Times free drop from 75cm height to hard wooden board of thickness more than 30mm	Frequency Change: ±10ppm Max. Resistance Change: ±15% or 5kΩ Max.
3	Hermetic seal	Checked: before the molded crystal units	less than 1×10^{-7} mbar.l/sec.
4	High temperature	240 hours at +85°C ± 2°C After 1-2 hours past at room temperature from following test.	Frequency Change: ±10ppm Max. Resistance Change: ±25% or 10kohm Max.



TYPE G3 Cylinder SMD Quartz Crystal

G33270007

VER. D 25-Apr-11

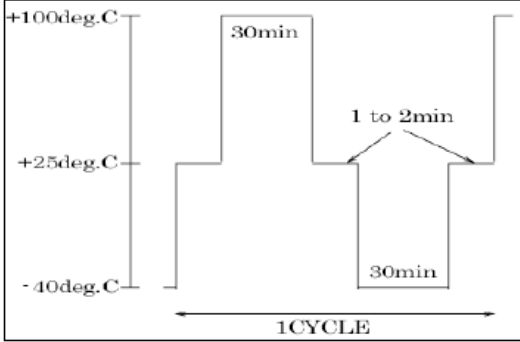
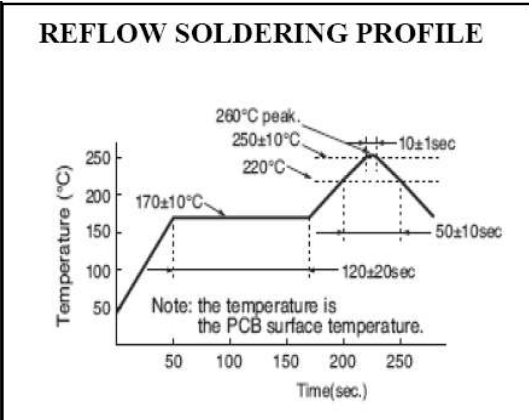
5	Low temperature	240 hours at $-40^{\circ}\text{C} \pm 2^{\circ}\text{C}$ After 1-2hours past at room temperature from following test.	Frequency Change: $\pm 10\text{ppm Max.}$ Resistance Change: $\pm 15\%$ or 5kohm Max.
6	Humidity	240 hours at $+85^{\circ}\text{C} \pm 2^{\circ}\text{C}$,relative humidity 90-95% After 1-2hours past at room temperature from following test.	Frequency Change: $\pm 10\text{ppm Max.}$ Resistance Change: $\pm 25\%$ or 10kohm Max.
7	Temperature cycle	After supplying the following temperature cycle (50cycles) 	Frequency Change: $\pm 10\text{ppm Max.}$ Resistance Change: $\pm 25\%$ or 10kohm Max.
8	Solderability	Dip the leads of crystal units into the solution (7-10%) of rosin 3 \pm 0.5s,then dip it into the tank 5-10s. Temperature of solder melted tank is $245^{\circ}\text{C} \pm 5^{\circ}\text{C}$	The dipped surface of the leads should be at least 95% covered with continuous new solder coating
9	Reflow soldering	The REFLOW SOLDERING PROFILE of Fig.1 for TMXLi-206F families. 	After 24h past from frequency test, Frequency Change: $\pm 10\text{ppm Max.}$ Resistance Change: $\pm 25\%$ or 10kohm Max. Notice: 1 · Using the infrared lamp at soldering process may cause uneven temperature rise on plastic surface of the parts,so that please keep the package temperature within left conditions. 2 · DO NOT dip the plastic part into solder.

TYPE G3 Cylinder SMD Quartz Crystal

G33270007

VER. D 25-Apr-11

MARKING

32768

DIMENSIONS (Unit:mm)

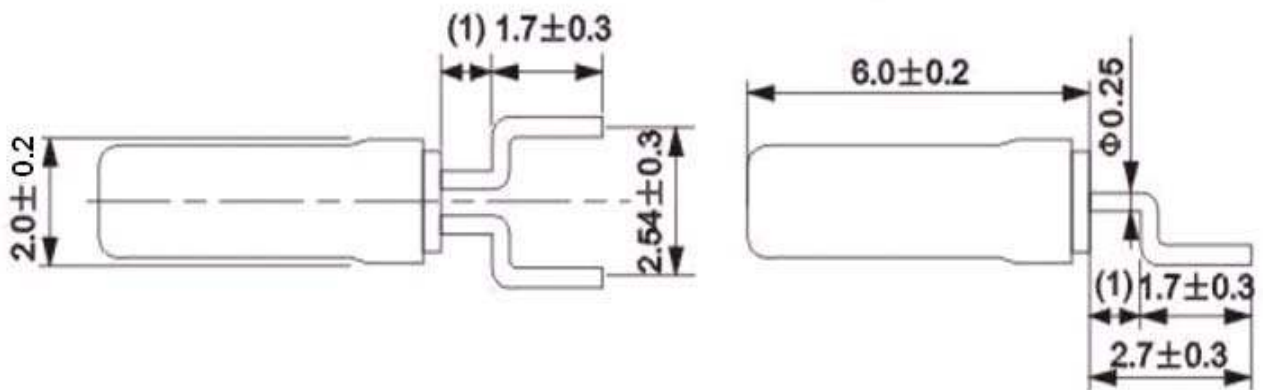

SOLDER PATTERN

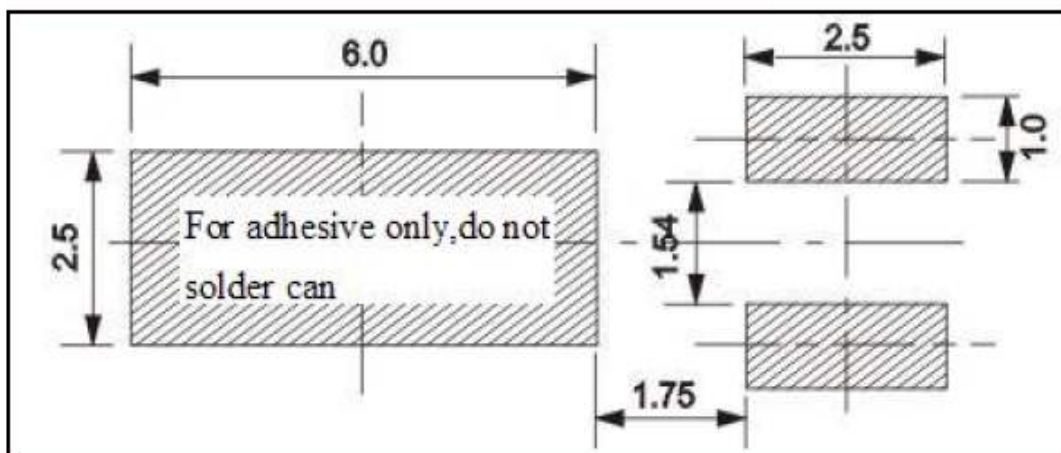

TYPE G3 Cylinder SMD Quartz Crystal

G33270007

VER. D 25-Apr-11

Packing

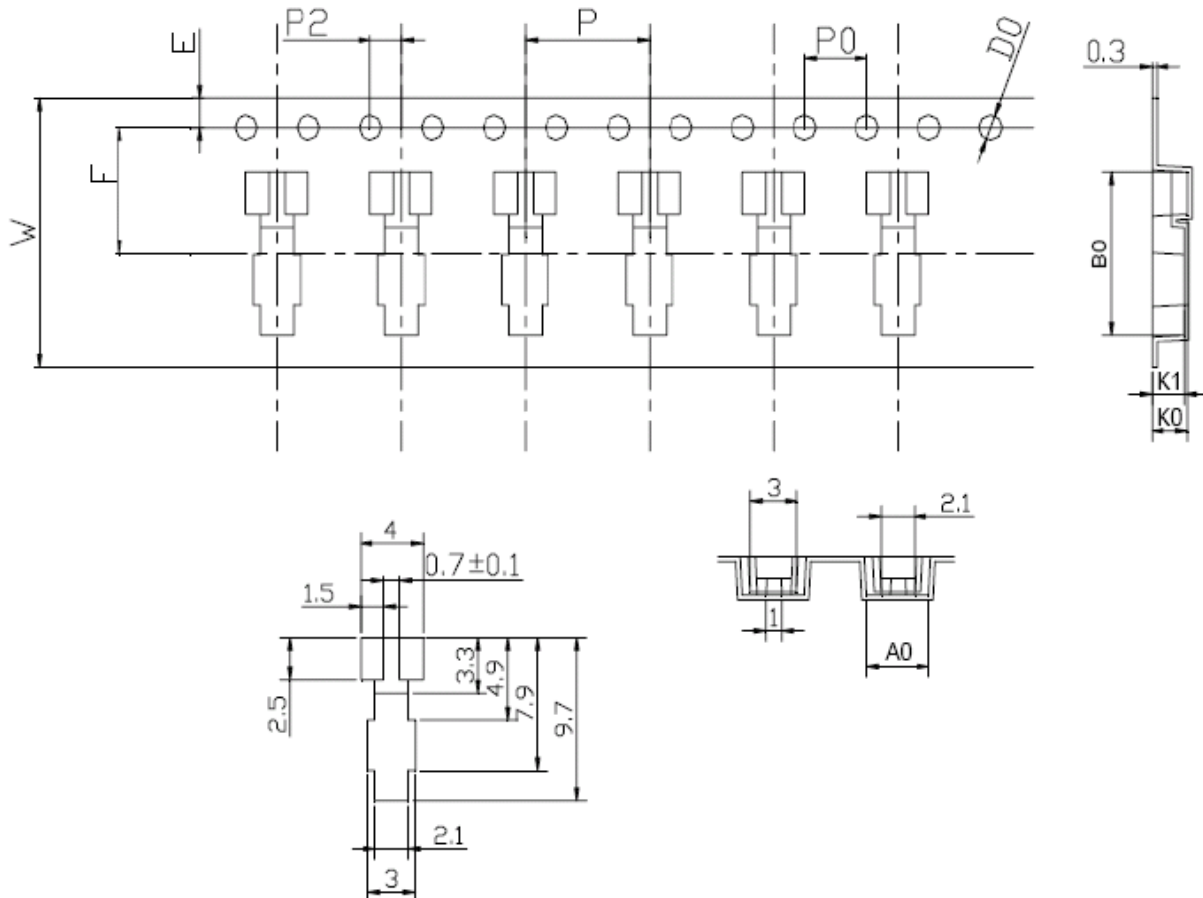

W	A0	B0	E	F	P	P0	P2	D0	K0	K1
16 ^{+0.30} _{-0.30}	4.0 ^{+0.10} _{-0.10}	9.7 ^{+0.10} _{-0.10}	1.75 ^{+0.10} _{-0.10}	7.5 ^{+0.10} _{-0.10}	8 ^{+0.10} _{-0.10}	4 ^{+0.10} _{-0.10}	2 ^{+0.15} _{-0.15}	1.5 ^{+0.15} _{-0.00}	2.3 ^{+0.10} _{-0.10}	2.1 ^{+0.10} _{-0.10}

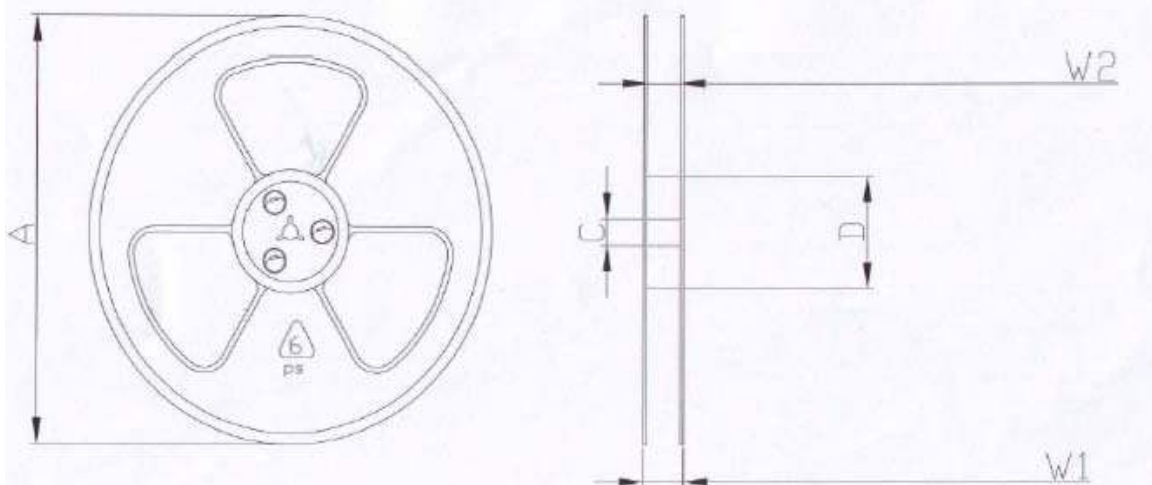

A±0.5	C±0.2	D±0.3	W1±0.2	W2 ^{+0.4} _{+0.2}
330	25	100	20	16

TYPE G3 Cylinder SMD Quartz Crystal

G33270007

VER. D 25-Apr-11

Packing

