

PRODUCT NUMBER  
SEE TABLE

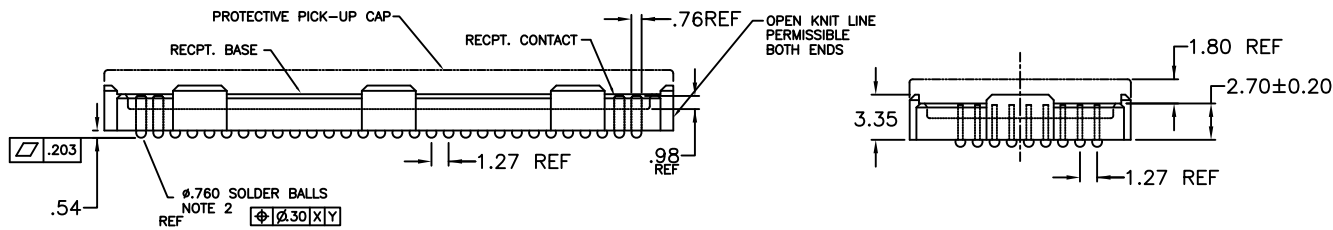
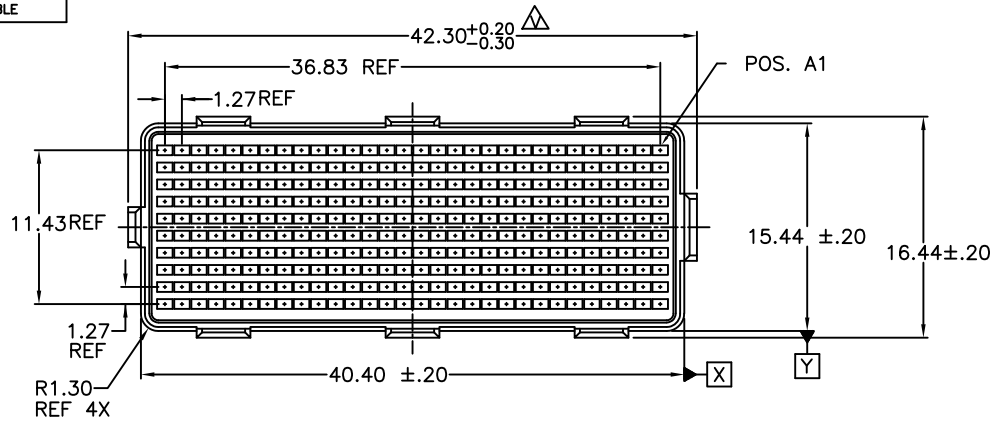

A

A

mat'l. code SEE-NOTE-1		surface ASMEY14.5		tolerance ASMEY14.5		projection MM		product family MEG-ARRAY	
lfr	ecn no	dr	date	tolerances unless otherwise specified		MM		title 4MM-RECPTACLE-ASSEMBLY. 10X30=300-POS	
N	V-13453-1	DCH	2012-11-14	angles	X±3	scale 1:1		dwg no 84501	
P	V-13453-1	DCH	2015-12-08	flatness	XX±.10	Amphenol FCI		sheet 1 of 4 size A4	
R	V-18087	DCH	2014-6-25	0°±2'	.XXX±.050			type CUSTOMER Drawing	
S	V-26025	RWB	2017-02-08	dr	D.WAUGHEN	1998-12-18			
T	V-40495	HCL	2021-03-26	enfr	D.HARPER	1998-12-18			
U	V-47222	LRJ	2023-02-07	chr	D.HARPER	1998-12-18			
V	V-47683	LRJ	2023-03-03	appd	D.HARPER	1998-12-18			
sheet index	revision sheet	V	V	V	V				
		1	2	3	4				

5

B

PRODUCT NUMBER  
SEE TABLE

STENCIL MATED CONNECTOR OUTLINE  
ONTO BOARD.

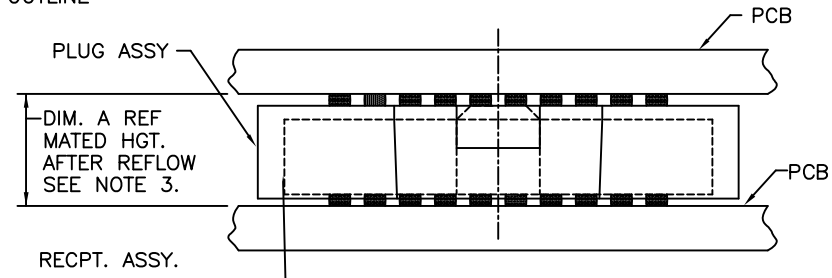
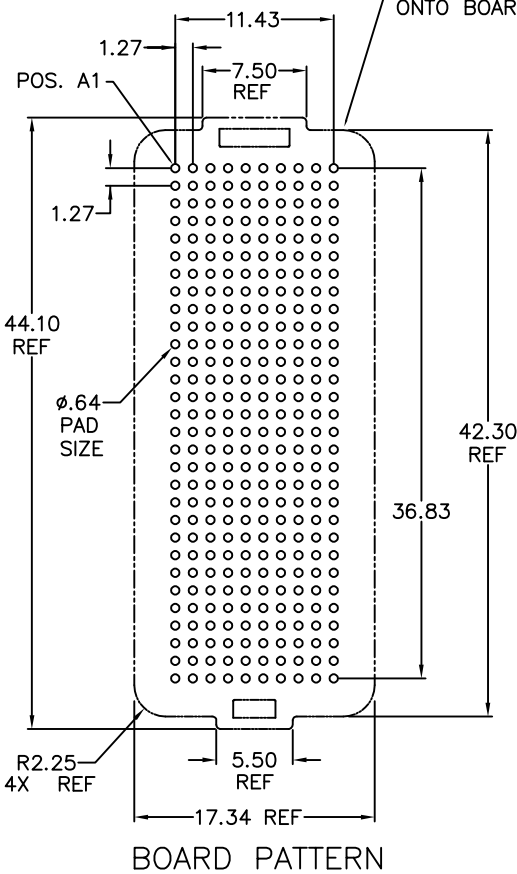
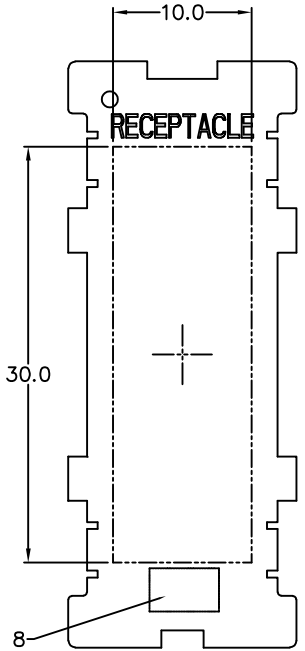

MATED HEIGHT TABLE		
DIM. A	PLUG ASSY. P/N	RECPT. ASSY. P/N
4.0	84500	84501
10.0	84578	84501

MATED HEIGHT AFTER REFLOW IS BASED ON Ø.64mm PAD (METAL-DEFINED) AND .13mm SOLDER PASTE STENCIL THICKNESS. SEE NOTE 3.

END VIEW - MATED CONNECTORS SCALE NONE

NOTE 8  
FLAT AREA FOR PICK-UP CAP

BOARD PATTERN

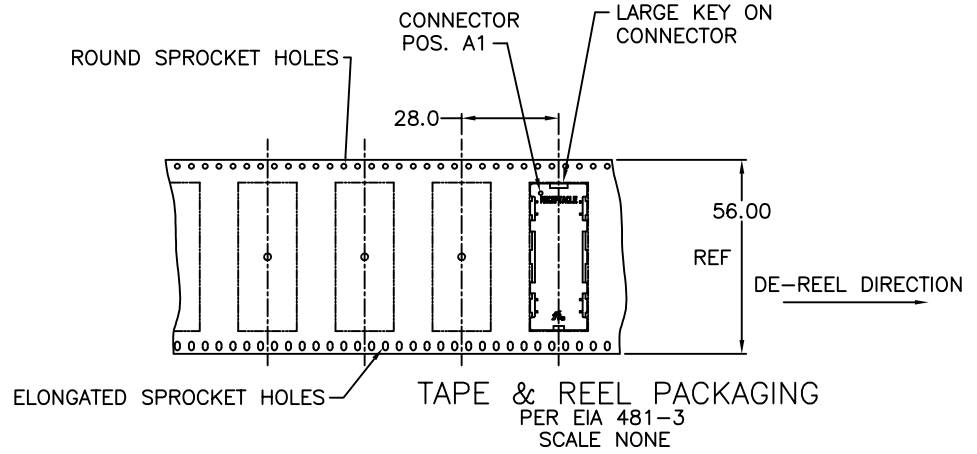

TAPE & REEL PACKAGING  
PER EIA 481-3  
SCALE NONE

mat'l. code SEE-NOTE-1		surface ASMEY14.5		tolerance ASMEY14.5		projection MM		product family MEG-ARRAY	
ltr	ecn no	dr	date	tolerances unless otherwise specified					
v				angle	.X±.3	MM	scale 1:1	title 4MM-RECPTACLE-ASSEMBLY. 10X30=300-POS	
				linear	.XX±.10				
				0'±2'	.XXX±.050				
		dr	D.WAUGHEN	1998-12-16	Amphenol FCI		dwg no 84501		sheet 2 of 4
		engr	D.HARPER	1998-12-16			type CUSTOMER Drawing		A4
		chr	D.HARPER	1998-12-16					
		appd	D.HARPER	1998-12-16					
sheet index	revision sheet	v	v	v	v				
		1	2	3	4				

PRODUCT NUMBER	PICK-UP CAP (NATURAL OR BLACK IN COLOR)	CONTACT PLATING AND THICKNESS	SOLDER BALL	NOTES
84501-001	YES	15µ" (.38µm) Au	SnPb	
84501-001BF	YES	15µ" (.38µm) Au	SnPb	12
84501-001LF	YES	15µ" (.38µm) Au	LEAD FREE	6
84501-001BLF	YES	15µ" (.38µm) Au	LEAD FREE	6 AND 12
84501-091	YES	15µ" (.38µm) GXT	SnPb	
84501-091BF	YES	15µ" (.38µm) GXT	SnPb	12
84501-091LF	YES	15µ" (.38µm) GXT	LEAD FREE	6
84501-091BLF	YES	15µ" (.38µm) GXT	LEAD FREE	6 AND 12
84501-093LF	YES	15µ" (.38µm) GXT	LEAD FREE	6 AND 11
84501-093BLF	YES	15µ" (.38µm) GXT	LEAD FREE	6, 11 AND 12
84501-101	YES	30µ" (.76µm) Au	SnPb	
84501-101BF	YES	30µ" (.76µm) Au	SnPb	12
84501-101LF	YES	30µ" (.76µm) Au	LEAD FREE	6
84501-101BLF	YES	30µ" (.76µm) GXT	LEAD FREE	6 AND 12
84501-191	YES	30µ" (.76µm) Au	SnPb	
84501-191BF	YES	30µ" (.76µm) Au	SnPb	12
84501-191LF	YES	30µ" (.76µm) Au	LEAD FREE	6
84501-191BLF	YES	30µ" (.76µm) Au	LEAD FREE	6 AND 12
84501-201	YES	50µ" (1.27µm) Au SPECIAL	SnPb	4
84501-201BF	YES	50µ" (1.27µm) Au SPECIAL	SnPb	4 AND 12
84501-201LF	YES	50µ" (1.27µm) Au SPECIAL	LEAD FREE	4 AND 6
84501-201BLF	YES	50µ" (1.27µm) Au SPECIAL	LEAD FREE	4, 6 AND 12
84501-291	YES	50µ" (1.27µm) GXT SPECIAL	SnPb	4
84501-291BF	YES	50µ" (1.27µm) GXT SPECIAL	SnPb	4 AND 12
84501-291LF	YES	50µ" (1.27µm) GXT SPECIAL	LEAD FREE	4 AND 6
84501-291BLF	YES	50µ" (1.27µm) GXT SPECIAL	LEAD FREE	6 AND 12
84501-A01	YES	30µ" (.76µm) Au SPECIAL	SnPb	7
84501-A01BF	YES	30µ" (.76µm) Au SPECIAL	SnPb	7 AND 12
84501-A01LF	YES	30µ" (.76µm) Au SPECIAL	LEAD FREE	6 AND 7
84501-A01BLF	YES	30µ" (.76µm) Au SPECIAL	LEAD FREE	6, 7 AND 12
<del>84501-301</del>	<del>YES</del>	<del>15µ" (.38µm) Au SPECIAL</del>	<del>SnPb</del>	<del>7</del>
<del>84501-301LF</del>	<del>YES</del>	<del>15µ" (.38µm) Au SPECIAL</del>	<del>LEAD FREE</del>	<del>6 &amp; 7</del>
<del>84501-401</del>	<del>YES</del>	<del>30µ" (.76µm) Au SPECIAL</del>	<del>SnPb</del>	<del>7</del>
<del>84501-401LF</del>	<del>YES</del>	<del>30µ" (.76µm) Au SPECIAL</del>	<del>LEAD FREE</del>	<del>6 &amp; 7</del>
<del>84501-501</del>	<del>YES</del>	<del>Au SPECIAL</del>	<del>SnPb</del>	<del>4 &amp; 7</del>
<del>84501-501LF</del>	<del>YES</del>	<del>Au SPECIAL</del>	<del>SnPb</del>	<del>4, 6 &amp; 7</del>

mat'l. code SEE-NOTE-1		surface ASMEY14.5		tolerance ASMEY14.5		projection 		product family MEG-ARRAY	
ltr	ecn no	dr	date	tolerances unless otherwise specified					
v				angles	linear	MM		title 4MM-RECTACLE-ASSEMBLY. 10X30=300-POS	
				0±2'	.XX±.10	scale 1:1		dwg no 84501	
				dr	D.WAUGHEN	1998-12-18	Amphenol FCI		sheet 3 of 4
				engr	D.HARPER	1998-12-18			size A4
				chr	D.HARPER	1998-12-18			
				appd	D.HARPER	1998-12-18			type CUSTOMER Drawing
sheet index	revision sheet	v 1	v 2	v 3	v 4				

NOTES:

- ①. MATERIAL  
HOUSING: LCP  
CONTACT: COPPER ALLOY  
  
PLATING  
CONTACT: (SEE TABLE ON SHEET3)  
SOLDER BALL: (SEE TABLE ON SHEET3)  
EUTECTIC SnPb OR LEAD FREE  
95.5Sn/4Ag/0.5Cu
- ②. SOLDER BALLS WILL NOT BE PERFECT SPHERICAL SHAPE DUE TO REFLOW ATTACHMENT.
- ③. MATED HEIGHT EFFECTED BY CUSTOMER'S PCB PAD SIZE, PLATING, SOLDER REFLOW PROFILE, & SOLDER PASTE.
- ④. PLATING FOR -2XX SERIES PRODUCT NUMBERS MEET THE REQUIREMENTS OF GR-1217-CORE, CENTRAL OFFICE ENVIRONMENT, (25 YEAR LIFE EXPECTANCY). THE CONTACTS IN THESE PRODUCT NUMBERS ALSO HAVE SPECIAL CONTACT GEOMETRY.
- ⑤. FOR PROPER APPLICATION FOLLOW FCI APPLICATION SPECIFICATION GS-20-033 LEAD FREE SOLDER BALLS WILL NOT SOLDER PROPERLY IN A LEADED SOLDER PROCESS DUE TO A HIGHER REFLOW TEMPERATURE. LEAD FREE PRODUCT IS THERFORE NOT BACKWARDS COMPATIBLE WITH LEADED OR SOME SOLDERING APPLICATIONS. REFERENCE FCI APPLICATION SPECIFICATION.
- ⑥. THIS PRODUCT MEETS EUROPEAN UNION DIRECTIVES AND OTHER COUNTRY REGULATIONS AS DESCRIBED IN GS-47-0004 PRODUCT MEETING THIS DIRECTIVE IS IDENTIFIED IN THE LOT CODE NUMBER MARKED ON EACH PART BY HAVING AN "X" IN THE SEVENTH CHARACTER POSITION.
- ⑦. 84501-A01 AND -A01LF ARE CUSTOMER SPECIALS.

- ⑧. CURRENT COMPANY LOGO TO BE VISIBLE IN APPROXIMATE AREA SHOWN.
- 9. 84501-301, -301LF, -401, -401LF, -501 and -501LF ARE OBSOLETE.
- 10. A  SYMBOL WILL BE NEXT TO ANY DIMENSION, NEW VIEW OR NOTE WHICH HAS BEEN MODIFIED WITH THE CURRENT DRAWING REVISION
- ⑪. 84501-093LF AND 84501-093BLF HAVE A SPECIAL CAP
- ⑫. FOR THESE DASH NUMBERS, PRODUCT IS BERYLLIUM FREE

mat'l. code SEE-NOTE-1		surface ASMEY14.5		tolerance ASMEY14.5		projection 		product family MEG-ARRAY	
ltr	ecn no	dr	date	tolerances unless otherwise specified					
v				angles	.X±.3	MM ←→	scale 1:1	title 4MM-RECPTACLE-ASSEMBLY. 10X30=300-POS	
				linear	.XX±.10				
				0'±2'	.XXX±.050				
		dr	D.WAUGHEN	1998-12-18	Amphenol FCi		dwg no	sheet 4 of 4	size
		engr	D.HARPER	1998-12-18	84501		A4		
		chr	D.HARPER	1998-12-18	CUSTOMER Drawing				
		appd	D.HARPER	1998-12-18					
sheet index	revision	v	v	v	v				
	sheet	1	2	3	4				